



**Università degli Studi Mediterranea di Reggio Calabria**  
Archivio Istituzionale dei prodotti della ricerca

Enhancing Cooperative Driving in IEEE 802.11 Vehicular Networks through Full-Duplex Radios

This is the peer reviewed version of the following article:

*Original*

Enhancing Cooperative Driving in IEEE 802.11 Vehicular Networks through Full-Duplex Radios / Bazzi, A., Campolo, C., Masini, B.m., Molinaro, A., Zanella, A., Berthet, A.o.. - In: IEEE TRANSACTIONS ON WIRELESS COMMUNICATIONS. - ISSN 1536-1276. - 17:4(2018), pp. 2402-2416. [10.1109/TWC.2018.2794967]

*Availability:*

This version is available at: <https://hdl.handle.net/20.500.12318/1422> since: 2022-05-20T10:44:53Z

*Published*

DOI: <http://doi.org/10.1109/TWC.2018.2794967>

The final published version is available online at: <https://ieeexplore.ieee.org/abstract/document/8267296>

*Terms of use:*

The terms and conditions for the reuse of this version of the manuscript are specified in the publishing policy. For all terms of use and more information see the publisher's website

*Publisher copyright*

This item was downloaded from IRIS Università Mediterranea di Reggio Calabria (<https://iris.unirc.it/>) When citing, please refer to the published version.

(Article begins on next page)

# Enhancing Cooperative Driving in IEEE 802.11 Vehicular Networks through Full-Duplex Radios

Alessandro Bazzi\*, Claudia Campolo, Barbara M. Masini, Antonella Molinaro, Alberto Zanella, Antoine O. Berthet

**Abstract**—On the path to zero fatalities on the roadways, all vehicles have to broadcast periodically cooperative awareness messages (CAMs) in a *timely* and *reliable* manner, even in areas of high traffic density. The carrier sense multiple access with collision avoidance (CSMA/CA) scheme of IEEE 802.11, the *de-facto* standard for vehicular communications, is known to offer no reliability to broadcast packets that cannot be acknowledged, and to poorly perform at high network load due to collisions and interference. In this paper, an enhanced CSMA/CA protocol is analysed for vehicular networks, which improves the CAM timeliness and reliability by leveraging full-duplex (FD) transceivers on board. FD devices can listen the channel while transmitting, so making collision detection (CD) viable. A FD vehicle can detect a CAM collision while sending, promptly abort the packet and retransmit it later. Results achieved through an analytical model under mathematically tractable assumptions, and through extensive system-level simulations in a complex urban environment, show the effectiveness of the protocol to cope with *direct collisions*, especially in high traffic areas, paving the way towards the realization of cooperative automated driving.

**Index Terms**—Full-duplex, V2X, VANETs, IEEE 802.11, MAC, CSMA/CA, broadcasting, CAM, cooperative driving, automated driving

## I. INTRODUCTION

Vehicle-to-Everything (V2X) communications play a crucial role to achieve smarter, greener and more integrated transport, claiming to be the main technology enabler for better mobility, improved transport fluidity, more road safety and security. On the path towards zero fatalities on the road, a clear evolution of applications is entailed: from simple *safety warnings* (e.g., emergency brake light warning, stationary vehicle warning, intersection collision warning) that make vehicles aware of road hazards or hidden obstacles; to *cooperative driving* (e.g., lane-merging assistance, platooning) based on the prediction of what other vehicles will do; to the ultimate challenge of *automated driving* with vehicles exchanging and synchronizing their driving trajectories [1]. Basically, all mentioned applications rely on the regular *broadcasting* of safety messages between neighboring vehicles. These messages can be more or less rich of information: from simple vehicle status (e.g.,

location, speed and direction), to more complex contextual and intentional information (e.g., enriched with data from on-board sensors like cameras and radar, and with driving trajectories). Vehicles' status information carried in cooperative awareness messages (CAMs) [2] are transmitted at a frequency between 1 and 10 Hz, with low-latency (maximum 100 ms) and high reception reliability (higher than 90%) requirements for cooperative driving. CAM requirements are much tighter for automated driving applications that need ultra-low latency (1 ms) and very high reliability (nearly 100%).

Today, IEEE 802.11 [3] is the standard vehicular communication technology; nodes that are not member of a basic service set (BSS) are allowed by its outside the context of a BSS (OCB) mode to promptly exchange data without preliminary authentication and association. Its carrier sense multiple access with collision avoidance (CSMA/CA) scheme is however known to offer no mechanism for reliable broadcasting and to suffer from poor performance at high traffic load [4]–[6] that will be the normal operating condition when the connected vehicles penetrate the market. The transmitters have no means to know about the packet success or failure, since broadcast packets cannot be acknowledged and the channel cannot be sensed while transmitting. Therefore, undetected collisions can neither trigger retransmissions nor adaptation of the contention window size to cope with congestion; the result is poor throughput and delay performance at high channel load. Designing an IEEE 802.11-compliant solution, which increases the reliability and the timeliness of broadcast safety data in areas of high traffic density, is the main motivation of the work reported in this paper.

We propose to leverage in-band full duplex (FD) transceivers<sup>1</sup> [7] on board as a means to make vehicles capable to sense the carrier while they transmit, so to enable collision detection (CD). CSMA/CA can therefore be enhanced with a CD mechanism for the recovery of broadcast packet failures that cannot instead be detected by legacy half duplex (HD) devices: FD transmitters in reciprocal radio coverage can early detect an impending (direct) collision<sup>2</sup>, immediately react by aborting the packet transmission and reattempt it later. To the best of our knowledge, we are among the first ones investigating FD in IEEE 802.11 vehicular networks; other works considered CD for cognitive radio applications [8], or they focused on a major redesign of medium access control

\*Corresponding author.

Alessandro Bazzi, Barbara M. Masini, and Alberto Zanella are with CNR - IEIIT, Viale Risorgimento 2, 40136 Bologna, Italy (e-mail: name.surname@ieiit.cnr.it).

Claudia Campolo and Antonella Molinaro are with Università Mediterranea di Reggio Calabria, Italy (e-mail: name.surname@unirc.it).

Antoine O. Berthet is with Laboratoire des Signaux et Systèmes (L2S), CentraleSupélec-CNRS-Université Paris-Sud, Université Paris-Saclay, 3, rue Joliot Curie, 91192, Gif-sur-Yvette, France (e-mail: antoine.berthet@centralesupelec.fr).

<sup>1</sup>Hereinafter, we will interchangeably refer to in-band FD and FD.

<sup>2</sup>A *direct* collision is due to transmitters in radio coverage that randomly select the same backoff.

(MAC) protocols, often non compliant with CSMA/CA [9], [10], to support FD bidirectional (unicast) communications, addressing infrastructured Wi-Fi networks [11], [12] or cellular networks [13], [14]. In our previous work in [15], we proposed a FD CSMA/CA protocol and showed the CAM performance improvement achieved by enabling CD on board. There, to ease the interpretation of results and to get preliminary insights into the FD potentials, the radio channel impairments and hidden terminals were not considered. Given the encouraging early results, in this paper we intend to take a step forward in both the rigorous theoretical and the realistic simulation assessment of the FD effects in a hostile interference-limited environment [16], [17]. In summary, the contributions of the present work are as follows:

- We analyse a broadcast CSMA/CA protocol for full duplex IEEE 802.11-OCB networks, exploiting the CD capability on board the vehicles. The protocol is compliant with classic CSMA/CA and does not require additional signaling for implementing the mechanisms of CD and packet abortion/retransmission.
- We define and validate an *analytical model*, which separately captures the impact of *direct collisions* and *hidden terminals* and permits us to evaluate the theoretical gain achievable by using CD to react to direct collisions of periodic CAM broadcasting, which is the typical and critical case for cooperative safety applications.
- We perform an extensive *system-level simulation campaign* to evaluate the actual CD effectiveness under different workload settings (i.e., CAM size, vehicle density), when considering: (i) realistic vehicular mobility traces in urban environments; (ii) a network simulator, accurately reproducing the IEEE 802.11 operations, properly overhauled to account for the CD capability; (iii) realistic signal propagation impairments and dynamics including, e.g., building obstructions; (iv) the presence of hidden terminals that could hinder the advantages of FD, and the capture effect at the receiver.
- We consider a set of *meaningful metrics* to assess the CD potential in improving CAM reliability and timeliness, and we investigate the *impact of specific parameters* (e.g., the collision detection time, the number of retransmission attempts after collision detection) expected to affect the protocol behavior.

The remainder of the paper is organized as follows. Section II provides an overview of FD communications and debates related issues and design at the physical (PHY) and MAC layers. Broadcasting operations in IEEE 802.11 vehicular networks are described in Section III, along with the main motivations behind our FD solution, which is presented in Section IV. The proposed analytical model and relevant results are reported in Section V, whereas simulation settings and results are presented in Section VI. Section VII concludes the paper and provides hints on future work.

## II. IN-BAND FULL-DUPLEX COMMUNICATIONS

In-band FD radio technologies will radically change the design of future transceivers, with the promise of nearly doubling

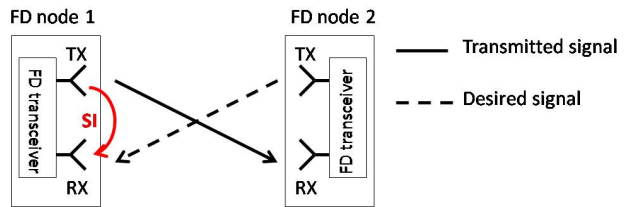

(a) Self-interference at a target node.

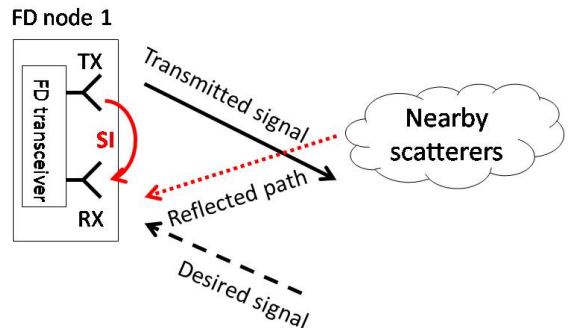

(b) Direct signal and multipath components from nearby scatterers contributing to self-interference.

Fig. 1. Self-interference at a device with separated antennas configuration.

the system spectral efficiency by allowing simultaneous signal transmission and reception in the same frequency band. In practice, the actual increase in capacity is limited by the self-interference (SI), unavoidably generated when the transmitted signal couples back to the receiving chain in the in-band FD transceiver, as shown in Fig. 1(a). Even though the transmitted signal in the digital baseband is perfectly known to the sender, eliminating the generated SI has been considered as the main hurdle to the progress of FD radio technologies. This is mainly due to (i) the large power discrepancy (with a ratio typically exceeding 100 dB) between the transceiver's own transmission and the signal of interest coming from a farther correspondent node, hence, subject to attenuation due to path loss and fading phenomena, and (ii) the multiple causes of analog signal distortions (nonlinearities, I/Q imbalance, etc.) and estimation errors in the transceiver chain.

To fully leverage the FD potential, issues at both the PHY and MAC layers should be tackled, by devising sophisticated PHY layer techniques in multi-stage receiver architectures and new MAC protocols, as discussed in more detail in the following.

### A. PHY Layer for FD: Issues and Design

Additional hardware/software components necessary for effective SI cancellation (SIC) complicate the transceiver design and consume operating power and resources. The resulting high cost and complexity of FD devices prevented so far the widespread usage of FD radios for small-form factor devices (e.g., consumer handheld devices, like smartphones and tablets).

Specifically, FD transceivers encompass both *passive* SI attenuation and *active* SIC techniques [7]. As a first step,

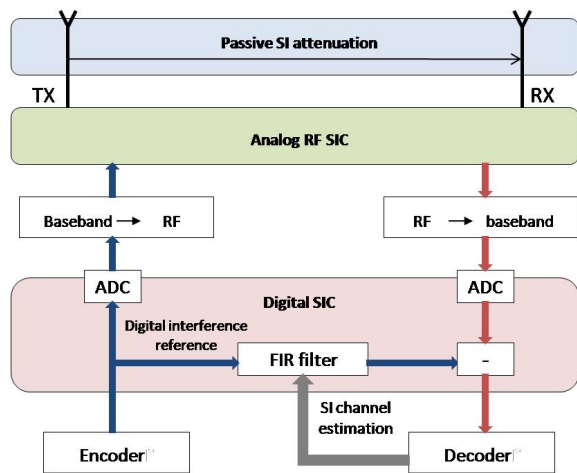

Fig. 2. Block diagram of FD SIC techniques in case of a device with separated antennas configuration (adapted from [9]).

passive SI attenuation suppresses part of the SI before it enters the receiver radio frequency (RF) chain circuit. FD transceivers can use the following antenna configurations: (i) shared antenna and (ii) separated antenna configurations [18]. In the former case, a single antenna is used for simultaneous in-band transmission and reception, through a three-port circulator, which prevents the leakage of signals from the transmit RF chain to the receive RF chain. In the latter case, the natural electromagnetic isolation (path loss) between antennas and polarization diversity can be exploited to reduce the level of SI at the ingress of the receiver. The effectiveness of passive SI attenuation is then affected by the accuracy of antenna positioning, signal bandwidth, transmit antenna and RF calibration [19]. As a second step, active SIC is applied in the analog and/or digital domain to cancel any residual SI by subtracting an estimated SI signal. These schemes incur an amount of processing overhead and latency [20], whose extent depends on the computation capabilities of the device hosting the FD transceiver. Active SIC in the analog domain reduces the required dynamic range of the analog-to-digital converter (ADC). Classical time-domain trained-based methods subtracting a modified copy of the transmitted signal from the overall received signal can be derived for both single- and multiple-antenna systems. The degree of freedom offered by the spatial dimension can be exploited in many ways (see, e.g., [20]). Active SIC in the digital domain is performed last, to attenuate the residual SI signal below the noise floor, so that co-channel interference may start dominating. The original transmitted signal, modified according to the effective channel experienced by the SI signal, is subtracted from the overall received signal. The effective channel includes the effects of the transmitter and receiver chains, active analog SI pre-cancellation, and multipath components reflected from antennas and nearby scatterers, as sketched in Fig. 1(b).

Recent experimentations have proved that all the aforementioned techniques, when combined together as depicted in Fig. 2, could achieve up to 70-110 dB SI cancellation (see, e.g., [7] and references therein).

## B. MAC Layer for FD: Issues and Design

Recent works have demonstrated the practicality of FD wireless PHY layer [9], [21], [22] and opened a path for the MAC layer redesign that is relatively new and steadily growing. MAC layer improvements are expected when FD is used to tackle the unsolved issues of distributed access protocols like the CSMA/CA in IEEE 802.11 networks:

- CD becomes possible: channel sensing is enabled while a signal is being transmitted, so that an FD node can realize whether other nodes in coverage are simultaneously transmitting.
- The hidden node problem can be counteracted: nodes hidden to the primary transmitter can sense the channel busy by the corresponding receiver and refrain from transmitting.
- The feedback delay is reduced: backward signaling, such as acknowledgment (ACK)/negative ACK (NACK), can be sent by the FD receiver while the sender is transmitting.

Two FD modes are considered in the related MAC literature: (i) *symmetric* (a.k.a. *bidirectional*) mode, when a pair of nodes simultaneously transmit and receive each other's data; and (ii) *asymmetric* (a.k.a. *relay*) mode, when a node targets a second one, which targets a third one, with the node in the middle acting as an FD relay simultaneously receiving from the first node and transmitting to the third one. In the former case, the system capacity can be doubled provided that the two links carry the same amount of data; misalignments due to packets that are offset in time and have different lengths may limit the achievable gain. In the latter case, the relay must have packets for the primary transmitter at the same time and for the same duration; the FD gain is reduced if either shorter packets or no packets are ready for being transmitted. Solutions have been proposed in the literature to make the best of FD and possibly double the capacity in the aforementioned modes. They targeted either *infrastructured* or *ad hoc networks*, as surveyed in [7]. In general, the FD benefits have been demonstrated in simple network topologies, but they could be hindered in practical scenarios under arbitrary topologies unless the 802.11 protocol is modified, which cannot ensure the co-existence of HD and FD devices.

In infrastructured networks with a FD access point (AP), coping with the additional inter-node interference created by multiple transmitters requires a proper scheduling of the concurrent links, e.g., through enhanced reservation procedures. A modified Request to Send/Clear to Send (RTS/CTS) channel reservation scheme is proposed in [12] to increase the probability of having bidirectional FD links. In [10] a novel RTS/full-duplex CTS (FCTS) mechanism is used, with the FCTS packet transmitted by both communicating nodes to set up an FD (symmetric or relay) link. Distributed power control is enabled to manage inter-node interference in [23], where the RTS/CTS reservation is used to estimate the channel gains and provide greater reception opportunities to clients with low interference. The coexistence of HD and FD nodes is addressed in some works such as [24] and [25]. Analytical modeling of the FD CSMA/CA dynamics has been

considered in [11] for saturated traffic conditions, and in [26] in unsaturated traffic conditions and for all types of FD modes.

When considering ad hoc networks, hidden terminals are the main concern. In [27], a contention-based FD protocol is designed with substantial changes in 802.11 PHY and MAC layers and in the MAC-PHY interface, e.g., different frame structures, sending/sensing busy tones while transmitting/receiving packets. In [28] busy tones are leveraged - to fill the remaining packet time or for the entire packet duration in case of misalignment - to prevent any hidden terminal from transmitting and causing a collision. In [29] RTS/CTS is combined with a new message exchange before the data transmission to decide the subset of neighbors that can transmit simultaneously. Instead of focusing on bidirectional FD communications as the majority of works do, the authors in [8], [30] focus on collision detection as a by-product of the FD technology, arguing about the CD potential for cognitive radio and spectrum sensing applications. Like most of FD MAC protocols in literature, they also consider unicast and saturated traffic conditions.

Overall, the literature lacks adequate analysis of an FD MAC layer in the dynamic and decentralized IEEE 802.11 vehicular network environments, mainly characterized by all-to-all broadcast communications, which are quite different from symmetric and asymmetric modes addressed so far. In this paper, we investigate the effect of CD in vehicular environments, focusing on (i) broadcast and unsaturated traffic conditions, in which the RTS/CTS reservation cannot be applied; (ii) infrastructureless topologies, where the absence of an AP complicates the channel access procedures and makes hard to take full advantage of FD; while (iii) designing a simple MAC extension that keeps backward compatibility with the legacy CSMA/CA.

### III. BACKGROUND AND MOTIVATIONS

#### A. FD in Vehicular Environments

The discussed PHY layer challenges in FD radios deployment can be largely mitigated when the devices are installed on board vehicles for several reasons [31]. First, vehicular on board units (OBUs) have less constraints in terms of form factor compared to handheld devices, so they can easily host separated transmit and receive antennas, e.g., placed on the vehicle rooftop, hence facilitating the deployment of passive SI attenuation schemes. Second, they provide large processing and power capabilities to run compute-intensive active analog and digital SIC algorithms. Last but not the least, given the early deployment stage for connected vehicle technologies, the FD implementation could be pushed without the need to address co-existence issues with HD devices, as it may be required in other mature wireless networks.

The benefits of FD in vehicular communications come at the price of a few serious constraints for OBUs, i.e., the design of ultra-agile analog and digital SIC algorithms capable to track the rapid fluctuations of the effective SI channel, due to moving scatterers and reflectors in the surrounding environment and to the high mobility of the device itself [22]. Preliminary experimental results presented in [22]

are encouraging for handheld FD mobile cellular devices with Orthogonal Frequency Division Multiplexing (OFDM)-modulation transceivers and passive isolation based on single shared antennas. Moreover, the work in [32] focuses on the problem of digital residual SIC in OFDM-modulated radio under typical vehicular mobility. Adopting a factor-graph framework, a reduced-complexity message-passing algorithm is derived suitable for joint channel estimation, residual SIC, symbol detection and decoding. The performance is quite satisfactory even for low pilot overhead and rapid temporal channel fluctuations. Therefore, we are confident that, in the near future, the specific issues posed by vehicular environments regarding SIC could be mitigated/solved and the FD technologies reach a level of maturity enabling a large deployment in next-generation vehicles.

#### B. Broadcasting in Vehicular Environments and the Issue of High Load

Broadcast traffic such as CAMs suffer from unreliability and packet losses in IEEE 802.11 networks, especially at high traffic load. Besides channel-induced losses due to radio propagation impairments, other losses can be either due to *direct collisions* or to *hidden collisions*, when multiple concurrent transmitters, respectively in radio coverage or reciprocally hidden, interfere on one or more common receivers. Unless upper-layer mechanisms are enforced, such losses cannot be recovered at the MAC layer because of the CSMA/CA rules: (i) broadcast packets cannot be acknowledged by the intended receivers, so failed transmissions cannot be detected and recovered by the sender; (ii) the lack of feedback on failed packets lets the contention window size unchanged with adverse performance effects under congestion, since multiple contending transmitters cannot benefit from the exponential contention window size increase in case of missed ACKs. In addition, the longer the size of colliding broadcast packets (and the lower the data rate<sup>3</sup>) the longer the collision duration and the consequent waste of channel resources.

Packet losses can be particularly detrimental to cooperative and automated driving applications that rely on the regular CAM exchange to enable safe maneuvers in critical situations, e.g., during lane changing and intersection crossings. Also, low latency and high reliability become difficult targets to achieve under congestion when the IEEE 802.11 performance heavily degrades. In [6], [33], it is shown that at high load CSMA/CA degrades towards an undesirable ALOHA performance, demonstrating the ineffectiveness of the carrier sense mechanism in providing a *guard zone* around the transmitters. In other words, at high density there is a non negligible probability that the nodes synchronously decrease their backoff counters down to zero, due to the granularity of the contention window size, and losses due to *direct collisions* worsen. Hence, workarounds need to counteract them so to improve the CAM reliability.

<sup>3</sup>Broadcast packets are typically transmitted at the lowest available data rate, which is known to be the most robust.

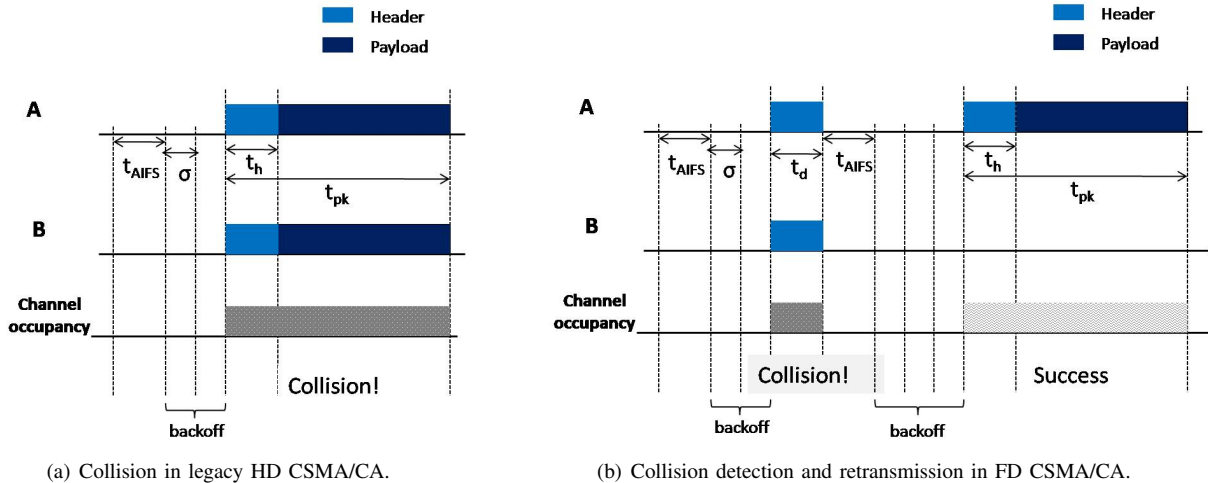

Fig. 3. HD vs FD broadcast CSMA/CA operation: two nodes in radio coverage extract the same backoff and transmit a CAM at the same time. (a) Colliding packets are not detected and waste channel resources; (b) Colliding packets are aborted and retransmitted (node A succeeds). Symbols are explained in Table I.

#### IV. EXPLOITING CD IN IEEE 802.11 VEHICULAR NETWORKS

The research in this paper builds upon our work in [15], in that it targets FD transceivers on board the vehicles enabled with CD capability to improve the broadcast CSMA/CA performance. The focus is on broadcasting due to the fact that it represents the typical communication mode for safety messages (CAMs) exchange in vehicular environments. The main idea in [15] is that as soon as an impending collision is detected by concurrent transmitters in radio coverage, they abort the packets and enforce retransmission after a random backoff delay, chosen within a doubled contention window size. The FD protocol operation is detailed in the following.

Similarly to legacy HD CSMA/CA, a node that is ready to transmit first probes the medium to determine whether it is busy or idle for a time,  $t_{AIFS}$ , equal to the Arbitration Interframe Space (AIFS). If the medium is busy then the node defers its own transmission of a random delay (backoff) to avoid collisions between multiple nodes that have been deferring to the same event. The backoff counter is computed as a random number of integer slot times selected from a uniform distribution over the interval  $[0, C_W]$ , with  $C_W$  the contention window size. The counter is decremented at the end of each slot while the medium is idle. If the channel is sensed busy at any slot time during the backoff countdown, then the counter is frozen until the medium is again sensed idle for a  $t_{AIFS}$  period. The frame is finally transmitted when the counter is zero.

Unlike legacy HD CSMA/CA, the CD is viable in FD transceivers, e.g., by means of energy detection. Detecting an impending collision on the radio channel is not instantaneous; it takes the so-called *collision detection time*<sup>4</sup>,  $t_d$ . If a node detects a received signal level that is above the clear channel assessment (CCA) sensitivity threshold, while it is transmitting, then after  $t_d$  it can detect an impending collision and abort the current packet. The sender goes through

the backoff process in order to retransmit the packet and repeats it until a non-collided transmission occurs or up to a maximum retry limit  $M$ . Replicas are transmitted as separate packets by following the standard channel access rules, but with the contention window size doubled at each retry to reduce the collision probability. An example comparing HD and FD CSMA/CA protocols operation is shown in Fig. 3. It illustrates what happens if two nodes in radio coverage,  $A$  and  $B$ , select the same backoff counter and transmit at the same time. With legacy HD, the colliding packets are entirely transmitted, resulting in the waste of channel resources. With FD, the two nodes abort the packet transmission after the collision detection time  $t_d$ , and reattempt transmission after selecting a new backoff from a doubled range.

In summary, the proposed FD CSMA/CA protocol for broadcast has the following advantages:

- It is simple and low-invasive, since it only requires OBUs to be able to detect concurrent transmissions by using the CD capability of FD nodes.
- It copes with the broadcast unreliability especially under congestion providing a means to (i) detect impending collisions without waiting for a feedback from the receiver(s); (ii) react to congestion by doubling the contention window size in case of packet failure; (iii) shorten collision duration by aborting packets as soon as the collision is detected.
- Although it targets broadcast packets under high-traffic load, it can be likewise applied to early detect unicast collisions at any channel load conditions.
- It is backward compatible with legacy CSMA/CA, since it does not require broadcast packets to be acknowledged; it does not need further signalling (e.g., busy tones or additional packets); and still it tries to have only one transmitter active at a time.

#### V. ANALYTICAL CONSIDERATIONS

Collision detection at the transmitter cannot be effective anytime the collision is due to hidden terminals, which are

<sup>4</sup>It can be equal to the frame header duration (typically, 40  $\mu$ s), as in [11].

out of the transmitter's radio range. In order to estimate how much CD can improve the CSMA/CA performance in an interference-limited environment, we extend the theoretical models in [34], [35] to evaluate separately the contribution of direct and hidden collisions. The model entails both spatial parameters related to the vehicle distribution - which allow an accurate estimation of the effect of aggregate interference - and queuing theory parameters capturing the MAC-layer dynamics. The model parameters are reported in Table I.

### A. Scenario and Assumptions

We consider a highway road segment abstracted as a one-dimensional (1-D) network model (Figs. 4(a) and 4(b)) with vehicles placed on a line according to a Poisson Point Process (PPP) with density  $\beta$ . This assumption holds [36]–[38] when the transmission range of vehicles is larger than the road width. Each vehicle generates CAMs of  $B_{\text{CAM}}$  bytes and transmission duration  $t_{\text{pk}}$  every  $\tau$  interval. The CAM generation instants at each vehicle are independent and randomly chosen. Fresh CAMs substitute outdated (backlogged) CAMs; this implies that the MAC queue can be either empty or with a single packet. All vehicles have the same, deterministic, transmission range, denoted by  $r_{\text{tx}}$ , and sensing range, denoted by  $r_{\text{sens}}$ ; the approximation is normally used for mathematical tractability (see, e.g., [34], [37]) and permits us to focus on MAC-layer dynamics. As a first approximation, we ignore the effects of imperfect SIC in the channel sensing process and assume that all concurrent transmissions within  $r_{\text{sens}}$  can be detected by a FD sender. Thus, we neglect false alarm (when a node wrongly detects a non-existent collision) and miss detection (if a node does not detect an actual collision) phenomena [39]. Channel-induced losses are not modeled, so CAM losses may only be due to collisions (direct or hidden) to permit us better isolating these events.

The model focuses on one tagged emitter  $\mathcal{S}$  and aims to derive the CAM collision probability as a function of the distance,  $d$ , between  $\mathcal{S}$  and a generic receiver  $\mathcal{D}$ <sup>5</sup>, when accounting for the aggregate interference at that distance. The performance as a function of the  $\mathcal{S}$ - $\mathcal{D}$  distance is, in fact, critical for cooperative driving that is sensitive to the vicinity at which CAMs are successfully received.

Given  $\mathcal{S}$  and  $\mathcal{D}$  at distance  $d$ , we identify the set of *hidden terminals* to  $\mathcal{S}$  and interfering on  $\mathcal{D}$  as the terminals that (i) are on the opposite direction than  $\mathcal{S}$  looking from  $\mathcal{D}$ , (ii) are more distant than  $r_{\text{sens}}$  from  $\mathcal{S}$  (they cannot sense the transmissions from  $\mathcal{S}$ ) and (iii) are less distant than  $r_{\text{tx}}$  from  $\mathcal{D}$  (their signal is strong enough to interfere at  $\mathcal{D}$ ). The road segment where these terminals, outside the sensing range of  $\mathcal{S}$  and within the transmission range of  $\mathcal{D}$ , are placed is hereafter called *hidden segment* and denoted as  $\ell_{\text{ht}}$ . It can be calculated as:  $\ell_{\text{ht}} = \max(d + r_{\text{tx}} - r_{\text{sens}}, 0)$ , where the function  $\max$  copes with the cases where  $d + r_{\text{tx}} - r_{\text{sens}}$  is negative, meaning that no vehicle can comply with all the points above and thus there are no hidden terminals.

<sup>5</sup>Being the scenario fully symmetric,  $\mathcal{D}$  is assumed on the right of  $\mathcal{S}$  without loss of generality.

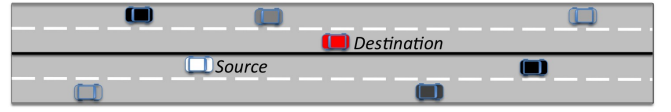

(a) Example 2-D two-lane scenario, then simplified into a 1-D network model.

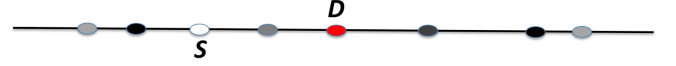

(b) Corresponding 1-D network model representation (each vehicle from the two lanes is mapped into a single point in a line).

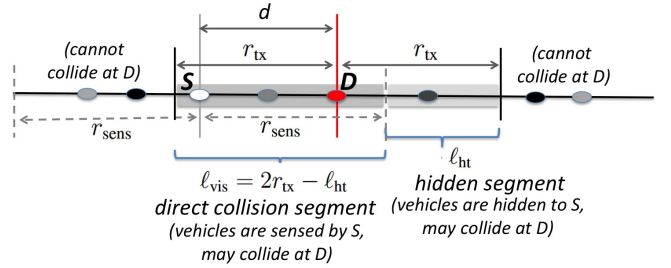

(c) Spatial parameters used in the analysis.

Fig. 4. Exemplification of the scenario and representation of the main symbols related to vehicle positions.

In addition, all vehicles that are (i) less distant than  $r_{\text{sens}}$  from  $\mathcal{S}$  (they can sense the transmissions from  $\mathcal{S}$ ) and (ii) less distant than  $r_{\text{tx}}$  from  $\mathcal{D}$  (their signal is strong enough to interfere at  $\mathcal{D}$ ) are the all and only nodes that are visible to  $\mathcal{S}$  and can cause direct collisions on  $\mathcal{D}$ . We name *direct collision segment* the line where nodes that can cause direct collisions are located. We denote it as  $\ell_{\text{vis}}$  that is calculated as:  $\ell_{\text{vis}} = 2r_{\text{tx}} - \ell_{\text{ht}}$ .

In Fig. 4(c), an example scenario is shown with the hidden and direct collision segments.

### B. Direct collision probability

A direct collision occurs when the tagged node  $\mathcal{S}$  senses the channel busy and selects a backoff slot for its transmission that is also selected by another node located in the direct collision segment. Thus, the probability of direct collision can be calculated as

$$p_{\text{c-dir}} = p_{\text{ss-dir}} \cdot p_{\text{busy}} \quad (1)$$

where  $p_{\text{ss-dir}}$  is the probability that another vehicle transmits in the same slot among those in  $\ell_{\text{vis}}$ , and  $p_{\text{busy}}$  is the probability to find the channel busy when the packet is generated.

**Evaluation of  $p_{\text{busy}}$ :** Let us denote as  $N_{\text{tr}}$  the average number of vehicles in the transmission range of  $\mathcal{S}$  (including  $\mathcal{S}$ ), calculated as

$$N_{\text{tr}} = 2r_{\text{tx}}\beta \quad (2)$$

where we recall that  $\beta$  denotes the density of vehicles. If all neighbors of  $\mathcal{S}$  transmit one packet in one CAM repetition interval without any time overlapping, the channel would be sensed busy for  $(N_{\text{tr}} - 1) \cdot (t_{\text{AIFS}} + t_{\text{pk}})$  seconds, with  $t_{\text{AIFS}}$  representing the AIFS duration and  $t_{\text{pk}}$  the CAM transmission time. However, collisions may occur that reduce such time

interval, so in order account for that, we denote the probability of collision between vehicles within the transmission range of  $\mathcal{S}$  as  $p_{c-tx}$  and assume that the probability that collisions occur among more than two packets is negligible compared to the one involving only two packets. It follows that the average portion  $p_{busy}$  of the CAM repetition interval occupied by a transmission from any vehicle other than the tagged node can be approximated as

$$p_{busy} = \frac{1}{\tau} (N_{tr} - 1) (t_{AIFS} + t_{pk}) \left(1 - \frac{p_{c-tx}}{2}\right) \quad (3)$$

where  $1/\tau$  averages over the CAM period,  $(1 - \frac{p_{c-tx}}{2})$  accounts for the collisions, and the only unknown variable is  $p_{c-tx}$ , the probability of collision between vehicles that are within the transmission range of  $\mathcal{S}$ . Similarly to (1),  $p_{c-tx}$  can be calculated as

$$p_{c-tx} = p_{ss-tx} \cdot p_{busy} \quad (4)$$

where  $p_{ss-tx}$  is the probability that another vehicle, among those in the transmission range of  $\mathcal{S}$ , transmits in the same slot. In order to calculate  $p_{ss-tx}$ , we first approximate the probability that a generic vehicle attempts to transmit in an arbitrary slot as

$$p_{\sigma} = 1 / (C_W + 1) \quad (5)$$

with  $C_W$  the contention window size; then we calculate the average time the queue is not empty,  $\theta_q$ , based on the following considerations. If the channel is busy, the node goes through a backoff process and extracts a random delay lasting on average  $\frac{C_W}{2}$  slots, with each slot lasting either  $\sigma$  (the IEEE 802.11 slot), if no other node is transmitting with probability  $(1 - p_{ss-tx})$ , or  $(\sigma + t_{AIFS} + t_{pk})$ , if any other node is transmitting with probability  $p_{ss-tx}$ . If the channel is idle then the CAM is transmitted immediately. In both cases, the node spends  $t_{pk}$  for the transmission. Thus,  $\theta_q$  results in

$$\theta_q = \frac{1}{\tau} \left( p_{busy} \left( (1 - p_{ss-tx}) \sigma + p_{ss-tx} (\sigma + t_{AIFS} + t_{pk}) \right) \frac{C_W}{2} + t_{pk} \right) \quad (6)$$

where  $1/\tau$  averages over the interval between consecutive CAM generations.

Given (2), (5), and (6),  $p_{ss-tx}$  can be obtained as

$$p_{ss-tx} = 1 - (1 - \theta_q p_{\sigma})^{N_{tr} - 1} \quad (7)$$

that corresponds to the probability that at least one of those vehicles that are in the transmission range of  $\mathcal{S}$  ( $N_{tr} - 1$  to exclude  $\mathcal{S}$  itself) have packets in the queue and select the same slot for transmission. Using Eq. (3) ( $p_{busy}$  as a function of  $p_{c-tx}$ ), Eq. (4) ( $p_{c-tx}$  as a function of  $p_{ss-tx}$ ), and Eq. (7) ( $p_{ss-tx}$  as a function of  $p_{busy}$ , through  $\theta_q$ ), the value of  $p_{busy}$  can be numerically derived.

**Evaluation of  $p_{ss-dir}$ :** Similarly to (7), given (5) and (6), and evaluating the average number of nodes in the direct collision segment as

$$N_{vis} = \ell_{vis} \beta \quad (8)$$

$p_{ss-dir}$  can be obtained as

$$p_{ss-dir} = 1 - (1 - \theta_q p_{\sigma})^{N_{vis} - 1} \quad (9)$$

**Direct collision probability:** Using the obtained values of  $p_{busy}$  and  $p_{ss-dir}$  in (1), we finally obtain  $p_{c-dir}$ .

### C. Hidden collision probability

Similarly to what described to calculate  $p_{busy}$ , let us calculate the average number of nodes in the hidden segment as

$$N_{ht} = \ell_{ht} \beta \quad (10)$$

and the average time (in seconds) their transmissions occupy the channel during one CAM period as

$$N_{ht} (t_{AIFS} + t_{pk}) \left(1 - \frac{p_{c-tx}}{2}\right) \quad (11)$$

where the last parenthesis accounts for collisions among hidden terminals that are supposed to be in the radio coverage of each other. Since the hidden transmissions are asynchronous with respect to the transmission from the tagged node, collisions may occur if the tagged transmission starts before or after the one from the hidden terminal. So, the vulnerable period, i.e., the time interval during which a collision might occur, can be approximated similarly to ALOHA as the double of the transmission time from nodes in the hidden segment, and the probability that a collision occurs can be approximated as

$$p_{c-ht} = \frac{1}{\tau} 2N_{ht} (t_{AIFS} + t_{pk}) \left(1 - \frac{p_{c-tx}}{2}\right) \quad (12)$$

where  $1/\tau$  averages over the CAM period.

### D. Analytical Results and Model Validation

For the model validation, a purpose-built simulator has been implemented in Matlab which replicates the behaviour of the considered protocols. Both results from the analytical model and from validating simulations are reported in Fig. 5, showing the collision probability when varying the average number of vehicles,  $N_{tr}$ , in the transmission range of the tagged source (hence, the vehicle density  $\beta$ ). The curves refer to  $r_{tx} = 200$  m and  $r_{sens} = 260$  m,  $B_{CAM} = 200$  and 400 bytes, with  $d = 50$ , 100, and 150 m, and show:

- *Collision probability without CD*, computed as  $1 - (1 - p_{c-dir}) \cdot (1 - p_{c-ht})$ , capturing the occurrence of both direct and hidden collisions, and so representing the performance of legacy HD CSMA/CA.
- *Collision probability with ideal CD*, computed as  $p_{c-ht}$ , accounting only for hidden collisions, and so capturing the FD capability of detecting and recovering a packet collision.

First, we observe that the simulation and analytical results are quite close, confirming the accuracy of the described model despite its simplicity. Then, we see that, in general, doubling the packet size or the vehicle density have a very similar impact. Comparing the curves without CD and with an ideal CD, the detection of direct collisions starts to have an impact when the number of neighbours increases. In particular, with the considered settings, the effect of an ideal CD starts to be visible with nearly 50-60 average neighbors with  $B_{CAM} = 200$  bytes, and with 25-30 average neighbors with  $B_{CAM} = 400$  bytes. This is because direct collisions are unlikely to occur under light traffic conditions.

The advantage becomes relevant under high vehicle density and, in particular, for smaller distances. Indeed, under such settings, the impact of direct collisions is stronger, because

(a)  $B = 200$  bytes.(b)  $B = 400$  bytes.

Fig. 5. Collision probability vs. average number of neighbors without CD and with an ideal CD. Comparison of analysis and simulation is included.

many vehicles may select the same backoff simultaneously, in alignment with the breakdown of CSMA/CA investigated in [33]. As an example, with  $B_{CAM} = 400$  bytes and  $N_{tr} = 100$  average neighbors, the ideal CD brings the collision probability down to almost zero if  $d = 50$  m and reduces it by more than 20% if  $d = 100$  m.

## VI. SIMULATIONS

The second step of our analysis entailed going deeper into the beneficial effects of CD that can be achieved in a realistic vehicular environment, capturing node mobility and radio propagation impairments in a scenario where the interference from hidden terminals can adversely affect the FD performance. Hence, additional results have been derived through simulations in a complex scenario that is hardly tractable using analytical models: an urban area with hundreds of vehicles moving using realistic traffic traces obtained with the VISSIM microscopic traffic simulator [40] on the simulation platform for heterogeneous interworking networks (SHINE) [41], which captures all layers operation, from the application layer to the

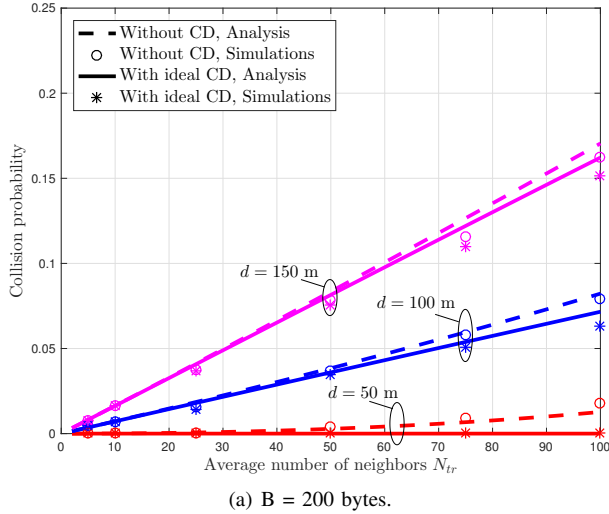
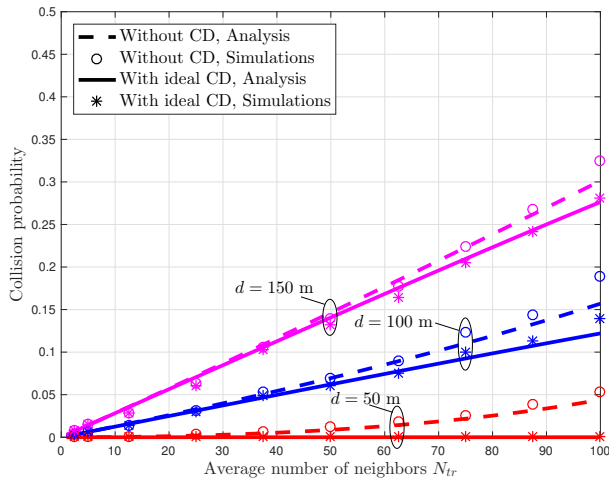
TABLE I  
INPUT PARAMETERS

Parameter	Value
Equivalent radiated power ( $P_{Tx}$ )	23 dBm
Gain of the antenna at the receiver ( $G_r$ )	3 dB
Minimum sensibility of the receiver ( $P_s$ )	-85 dBm
Minimum SINR ( $\gamma_{min}$ )	13 dB
Noise power ( $P_N$ )	-95 dBm
Attenuation at 1 m ( $L_0$ )	47.86 dB
Path loss exponent ( $\alpha$ )	2.31, 2.61
Additional path loss per each external wall	9 dB
Additional path loss per each meter in a building	0.4 dB
Standard deviation of the log-normal shadowing	1.7 dB
Modulation	QPSK
Coding	Convolutional, rate 1/2
Transmission data rate	6 Mb/s
Slot time ( $\sigma$ )	13 $\mu$ s
Contention window size ( $C_W$ )	15
Arbitration Inter-Frame Space duration ( $t_{AIFS}$ )	58 $\mu$ s
Header time ( $t_h$ )	40 $\mu$ s
Channel configuration	SCH172, no switching
CAM repetition interval ( $\tau$ )	100 ms
CAM payload size ( $B_{CAM}$ )	100, 200, 400, 800 bytes
CAM transmission duration ( $t_{pk}$ )	184, 312, 584, 1112 $\mu$ s
Collision detection time ( $t_d$ )	$t_h, 2t_h, 4t_h, 6t_h$
Maximum number of attempts ( $M$ )	2, 3, 5, 10, 20, $\infty$

physical layer. The main simulations settings are summarized in Tables I and II.

### A. Simulation settings and metrics

**CSMA/CA settings.** IEEE 802.11-OCB is simulated as the vehicular communication technology supporting periodic CAM transmissions. In agreements with the OBU deployment option pushed by automotive industries [42], CAMs are sent on one channel (SCH 172) assigned for their *exclusive* use only; thus, no background traffic is simulated on this channel and no channel switching intervals are therefore considered. All CAMs are transmitted at 6 Mbps (adopting 4-QAM and coding rate 1/2), which is suggested as the optimal data rate for broadcasting in, for example, [43].

Standard CSMA/CA is implemented, and extended with collision detection and CAM retransmissions for the FD operation. Hidden terminals, exposed terminals, and capture effects are included. The channel is sensed busy if the received power is higher than the receiver sensitivity  $P_s = -85$  dBm. The signal to noise and interference ratio (SINR) is calculated as the ratio between the average received power and the sum of the noise power  $P_N = -95$  dBm and the average power from all the interferers. A packet is correctly decoded if the SINR is higher than a threshold  $\gamma_{min} = 13$  dB.

Perfect SIC is assumed for FD nodes, which results in no occurrence of false alarm or miss detection events. This permits us to isolate the PHY-layer artifacts and focus on the MAC-level gain. SIC delay is instead simulated, similar to [11]

and [30], accounting for the processing overhead necessary for detecting a simultaneous transmission on the medium. This is captured through the collision detection time parameter  $t_d$ , which is set equal to the header time  $t_h$  (40  $\mu$ s), as in [11], or multiples of  $t_h$ . So, with FD a CAM transmission is aborted if the channel is sensed busy after  $t_d$ ; in other words CD is *not immediate*.

**Radio propagation.** All nodes use an equivalent radiated power (ERP)  $P_{tx} = 23$  dBm and an antenna gain at the receiver  $G_r = 3$  dB. In line of sight (LOS) conditions, the path loss (in dB) is modeled as  $L_0 + 10 \cdot \alpha \cdot \log_{10}(x) + X_S$ , where  $L_0 = 47.86$  dB is the attenuation in free space conditions at 1 m at 5.9 GHz,  $\alpha$  is the path loss exponent,  $x$  is the source-destination distance, and  $X_S$  is a log-normal random variable that accounts for shadowing, with zero mean and variance equal to 1.7 dB [44]. When buildings impair the LOS, an additional loss is considered of 9 dB per each external wall and 0.4 dB per meter inside the buildings [45]. The path loss exponent  $\alpha$  is selected in the range 2-2.8, which is typical for short range communications at 5.9 GHz (e.g., [45]–[47]), in order to obtain different transmission ranges in LOS conditions. This is a common way, used when working with realistic traffic traces, to change the number of neighbors (i.e., the number of vehicles in radio coverage), with a similar effect as a variation of the node density, as detailed in the following.

**Simulated scenarios.** The vehicular mobility is generated by VISSIM traffic traces referring to a 1.6x1.8 km<sup>2</sup> map portion of the Italian city of Bologna. The traffic simulator takes into account driving rules and the presence of vehicles, roads and buildings. The time-varying vehicles positions resulting from the mobility traces capture the dynamics of reception, by accounting for the vehicle neighborhoods under realistic road conditions (e.g., fluid or congested traffic), which is one of the main objectives of the simulation campaign.

Two scenarios are simulated, respectively considering fluent and congested traffic, as summarized in Table II:

- the *few neighbors* scenario, where a vehicle has a *limited number of neighbors*. Mobility traces capture a *fluent traffic* situation with 150 vehicles/km<sup>2</sup> on average; a transmission range of 200 m is achieved by fixing the path loss exponent to 2.61.
- the *many neighbors* scenario, where a vehicle has a *large number of neighbors*. Mobility traces capture a *congested traffic* situation with an average density of 230 vehicles/km<sup>2</sup>; a transmission range of 400 m is achieved by setting the path loss exponent equal to 2.31.

The different numbers of neighbors in the two scenarios serve the purposes of investigating the potential of CD under different interference patterns. In fact, in the two scenarios, having a small or a high number of neighbors implies having a different number of interfering nodes causing direct collisions, a different number of hidden terminals, and different interference levels contributing to make the channel busy. To give a clear picture of the traffic conditions assumed in these scenarios, in Fig. 6 we show the complementary cumulative distribution function (CCDF) of the number of neighbors. The median value (corresponding to a CCDF of 0.5) goes from

TABLE II  
CONSIDERED SCENARIOS

Name of the scenario	Selected		Consequence			
	Traffic	$\alpha$	v./km <sup>2</sup>	$r_{tx}$	$r_{sens}$	Average neigh.
Few neighbors	Fluent	2.61	150	200 m	260 m	15
Many neighbors	Congested	2.31	230	400 m	540 m	63

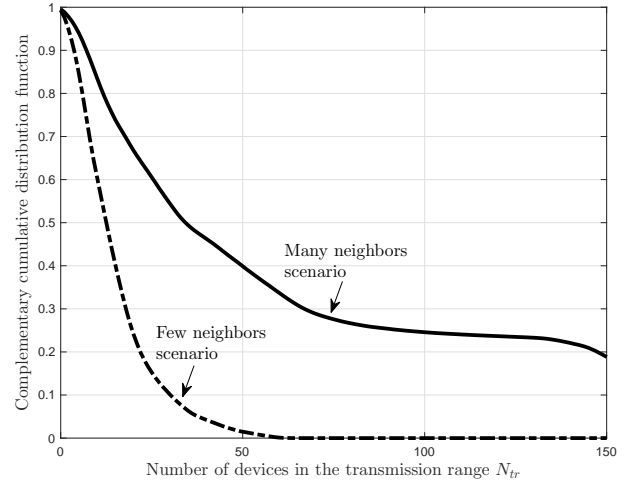

Fig. 6. CCDF of the number of vehicles in the transmission range for the considered scenarios.

12.5 for the few neighbors scenario up to 34 for the many neighbors case. In the few neighbors scenario the probability to have at least 50 neighbors is lower than 0.02, whereas in the many neighbors scenario the probability to have at least 100 neighbors (the double) is higher than 0.2 (greater of one order of magnitude).

**Output metrics.** The system performance is evaluated in terms of the following metrics:

- *CAM delivery fraction*  $\rho$ , which is computed as the percentage of neighbors correctly decoding a CAM at a given distance from the transmitter.
- *CAM range*  $r_{CAM}$ , which corresponds to the maximum distance from the transmitter at which the CAM delivery fraction,  $\rho$ , remains above the 0.9 threshold. This threshold is fixed in accordance with the typical minimum requirement for the radio layer message reception reliability [48].
- *Update delay*  $L_{CAM}$ , which is the time difference between two consecutive successfully received CAMs from the same vehicle. It describes the up-to-dateness of the status information: the higher the update delay the longer no CAM has been received from a given neighbor.

The first two metrics measure the CAM reliability, whereas the third one indicates the CAM timeliness. They are valuable metrics to assess *if* and *to which extent* the proposed FD solution can improve cooperative driving applications.

## B. Simulation results

Results compare classic CSMA/CA under normal operation, i.e., *without CD*, and FD CSMA/CA, i.e., *with CD* enabled to

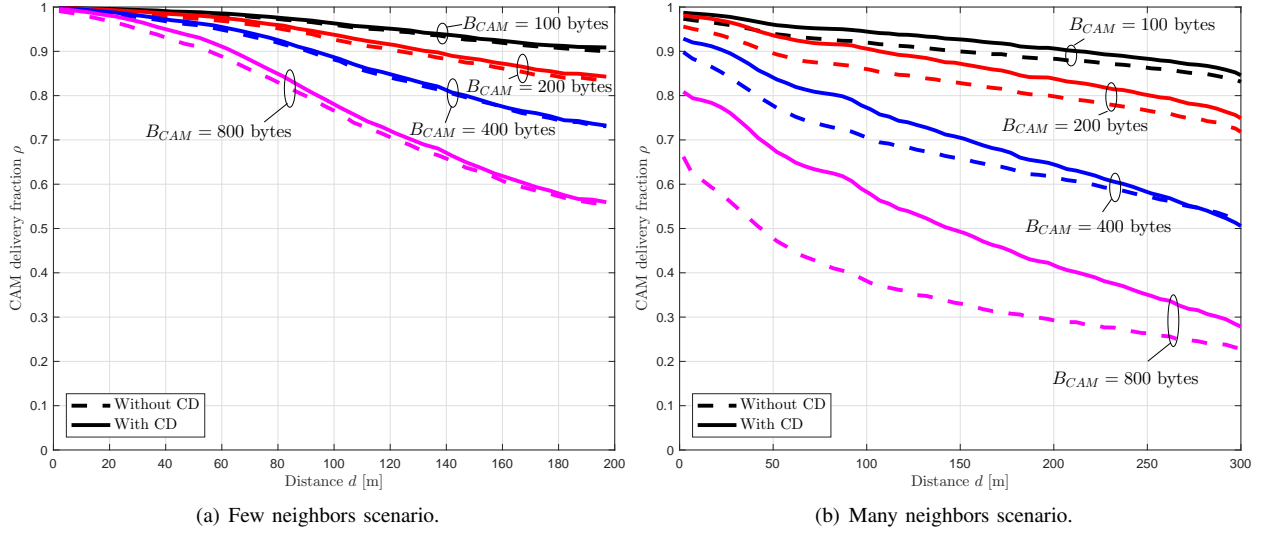

Fig. 7. Performance comparison with and without CD: CAM delivery fraction vs. source-destination distance ( $t_d = t_h$ ,  $M = \infty$ , variable CAM size).

improve reliability and timeliness of broadcast transmissions. Unless differently specified, the collision detection time is set equal to the frame header duration ( $t_d = t_h$ ), and an infinite number of retransmission attempts (i.e.,  $M = \infty$ ) is assumed.

**Varying the CAM size.** In Fig. 7 the CAM delivery fraction is presented as a function of the source-destination distance for different values of the CAM size,  $B_{CAM}$ , in the few and many neighbors scenarios. The CAM delivery fraction decreases with the source-destination distance, due to worse channel conditions, and more remarkably in the many neighbors scenario and for large CAM sizes, due to the heavier contention.

It is interesting to observe that, coherently with the analysis provided in Section V, the FD advantages increase with the congestion level over the channel. A higher congestion corresponds to a higher average number of neighbors and longer CAMs. Indeed, for any CAM size FD can provide only a small improvement in the few neighbors scenario (Fig. 7(a)), whereas the improvement is significant when the number of neighbours and the CAM size increase (Fig. 7(b)).

For example, in Fig. 7(b) at 50 m distance from the source, with FD the CAM delivery fraction increases of nearly 2% with  $B_{CAM} = 100$  bytes and of more than 40% with  $B_{CAM} = 800$  bytes. It is also interesting to note that, in all cases, FD becomes less effective at larger distances from the source. This is because far from the transmitter the impact of other impairments due to radio propagation and interference gets stronger compared to the effect of direct collisions. Also this consideration is in line with the theoretical results shown in Section V.

The CAM reliability is further investigated in Fig. 8 in terms of CAM range, when varying  $B_{CAM}$  and targeting a CAM delivery fraction of 0.9. For example, if we focus on  $B_{CAM} = 200$  bytes, in the few neighbors scenario the CAM range only increases from 123 m to 133 m with FD; in contrast, in the many neighbors scenario the range nearly doubles from 50 m without CD to more than 100 m with CD. In general, large CAMs (i.e., 800 bytes) do not comply with the target 90% delivery fraction in the many neighbors

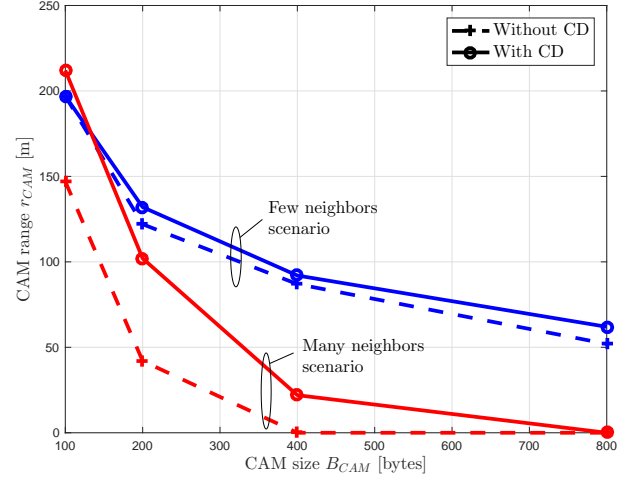

Fig. 8. Performance comparison with and without CD: CAM range vs. CAM size ( $t_d = t_h$ ,  $M = \infty$ ).

scenario and do not reach more than 60 meters range in the few neighbors case. Last, the CAM range shrinks with a higher number of neighbors (except for  $B_{CAM} = 100$  bytes, where the maximum  $r_{tx}$  of 200 m upper bounds the performance in the few neighbors case). Notably, with FD radios, CAM ranges larger than 100 m can be obtained by CAMs not exceeding 200 bytes, even in congested scenarios. The same achievement is possible without CD only with CAMs shorter than 100 bytes.

The CCDF of the CAM update delay is shown in Fig. 9 when setting  $B_{CAM} = 100$  and 800 bytes in the two reference scenarios. The results only account for vehicles which are less than 100 m from each other. With  $B_{CAM} = 100$  bytes, a not negligible reduction of the update delay is obtained with FD that almost halves the probability to miss an update within 200 ms in both scenarios. The same observation also holds for  $B_{CAM} = 800$  bytes in the few neighbors scenario. If we look at  $B_{CAM} = 800$  bytes in the many neighbors scenario, although FD seems ineffective at short delays, the advantage becomes

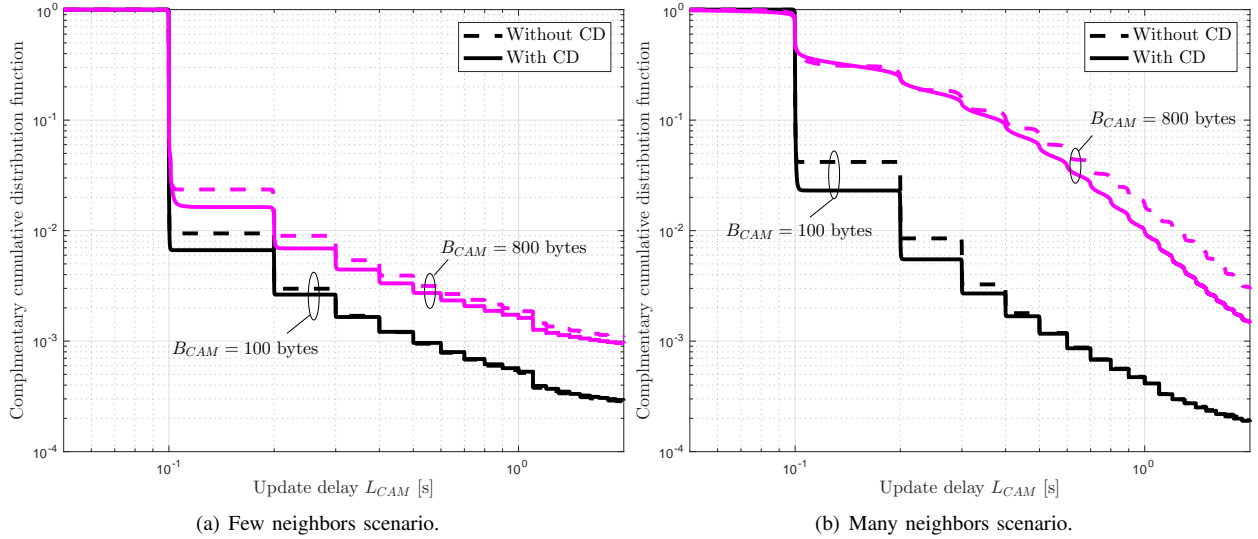

Fig. 9. Performance comparison with and without CD: CCDF of the update delay for vehicles less than 100 m far from each other ( $B_{CAM} = 100$  bytes or 800 bytes,  $t_d = t_h$ , and  $M = \infty$ ).

appreciable at larger update delays. For example, with FD the probability that the update is delayed more than 2 seconds is reduced from approximately  $3 \cdot 10^{-3}$  to nearly  $1.5 \cdot 10^{-3}$ .

**Varying the collision detection time.** Figs. 10(a) and 10(b) show the effect of different collision detection time,  $t_d$ , values. Specifically, in Fig. 10(a) the CAM range is shown versus  $t_d$  for  $B_{CAM} = 200$  and 400 bytes in both reference scenarios, whereas in Fig. 10(b) the CAM delivery fraction is plotted versus the distance from the source for  $B_{CAM} = 400$  bytes in the many neighbors scenario, when  $t_d = t_h$  and  $4t_h$ . As observable in Fig. 10(a), a longer collision detection time does not significantly affect the CAM range, except for the most congested case, i.e., in the many neighbors scenario with  $B_{CAM} = 400$  bytes, when a  $t_d$  higher than  $80 \mu s$  drastically limits the FD advantage and the CAM range falls down to zero as with HD. A longer collision detection time before aborting the ongoing transmission may override the benefits of a prompt retransmission, since the channel stays busy for a longer time and contention and collisions increase. In this case, not only FD has a small advantage for vehicles in the 100 m neighborhood, but, as shown in Fig. 10(b), it may even worsen the CAM delivery fraction to farther vehicles. Moving the receiving vehicle farther, in fact, the hidden terminal segment increases and the FD efficiency decreases.

**Varying the maximum number of retransmission attempts  $M$ .** The effect of a limited number of retransmissions is finally analyzed, varying  $M$  in the FD scheme. Fig. 11(a) depicts the CAM range versus the maximum number of attempts,  $M$ , for  $B_{CAM} = 200$  and 400 bytes in both reference scenarios. It highlights that  $M$  slightly affects the results when passing from 2 (at most one retransmission) to 5; further increase in  $M$  has a negligible impact in most cases. Interestingly, the increase in  $M$  may have a positive or negative impact depending on the scenario and CAM size. When the channel is underused (few neighbors) a larger  $M$  allows more tries and eventually one of them successfully reaches the destinations, resulting in a longer CAM range. In contrast, when the channel

is congested (many neighbors and  $B_{CAM} = 400$  bytes) a larger  $M$  has the main effect to further increase the congestion, and hence the collisions, with an overall resulting reduction of the CAM range.

The many neighbors scenario with  $B_{CAM} = 400$  bytes is further analyzed in Fig. 11(b) in terms of CAM delivery fraction versus the distance from the transmitter. CD curves with only  $M = 2$  and  $M = 5$  are compared to the standard HD for the sake of readability. They clearly show the different effect that the number of attempts has depending on the source-destination distance. By increasing the distance from the source, the hidden segment increases in size, thus the positive effect of FD in reducing direct collisions is traded off with the increase in the hidden collisions.

The impact of  $M$  on the update delay is illustrated in Fig. 12, with reference to both scenarios and  $B_{CAM} = 400$  bytes. When the channel is far from congestion (few neighbors scenario, Fig. 12(a)), the update delay shows a clear step-wise shape: most messages are sent just after their generation and the various steps correspond to the number of consecutive losses observed at the receiver. For example, if we focus on the curve without CD, there is approximately 0.02 probability that one message is lost (and the following correctly received) and 0.005 probability that there are two consecutive losses. Comparing the cases with and without CD, it is evident that the update delay is reduced with FD devices. As expected from the previous results, a slight improvement is observable when increasing  $M$  from 2 to 5; more retransmission attempts achieve a lower CAM loss probability.

When the channel tends to congestion (many neighbors scenario, Fig. 12(b)), the step-wise behavior is still visible for the cases without CD and with CD and  $M = 2$ , with significantly higher values of the update delay compared to the previous scenario and a small improvement of the FD over the HD. When increasing  $M$  to 5 the shape of the curve changes; in this case a CAM is often successfully transmitted

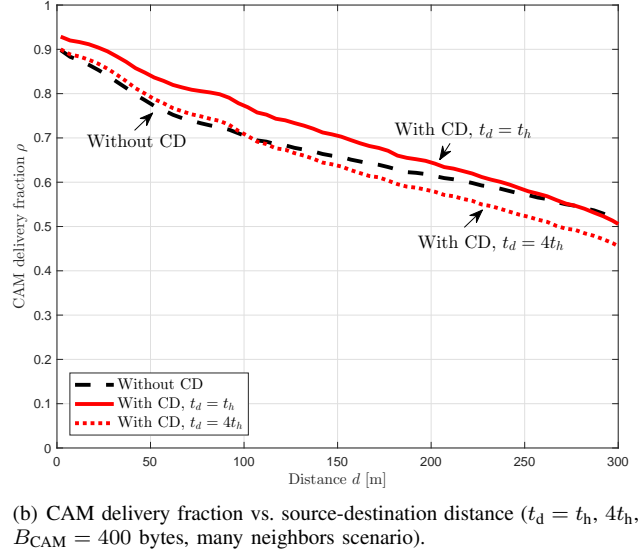
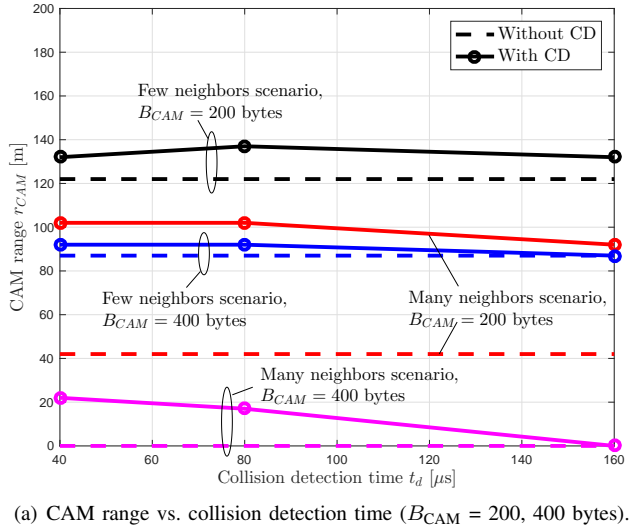

Fig. 10. Performance comparison with and without CD: effect of the collision detection time  $t_d$  ( $M = \infty$ ).

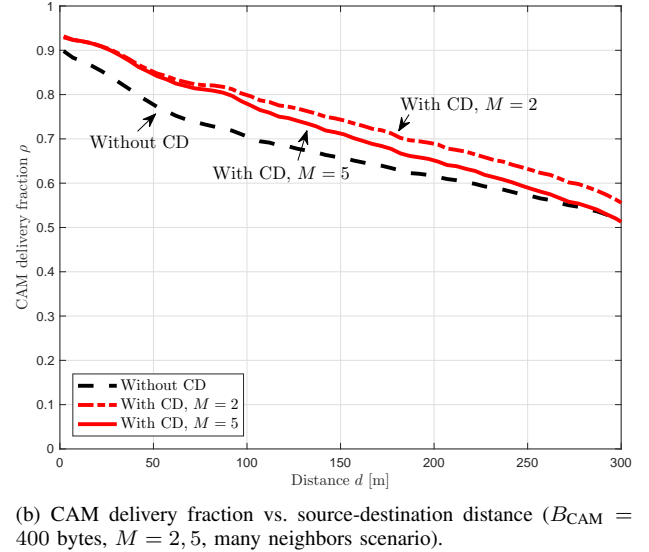
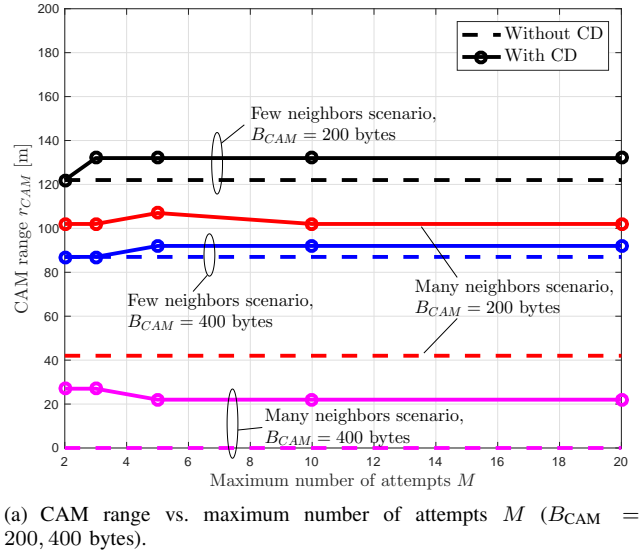

Fig. 11. Performance comparison with and without CD: effect of the maximum number of retransmission attempts  $M$  ( $t_d = t_h$ ).

after a not negligible delay due to repeated interruptions and retransmission attempts. Comparing it to the other two cases, a slightly higher probability can be noted of having an update delay lower than approximately 135 ms, but a slightly lower probability of getting a delay higher than that value. The differences between  $M = 2$  and  $M = 5$  are anyway very small in all cases.

## VII. CONCLUSIONS AND FUTURE WORK

In this paper, we analyzed the potential for FD to improve the reliability and latency of broadcasted CAMs in IEEE 802.11 vehicular networks for cooperative and automated driving purposes. The capability of FD devices to simultaneously transmit and sense over the same frequency band permits to detect an impending collision and recover through a prompt packet abort and a late retransmission.

A two-step methodology has been followed in this work. The first step entailed the design of an *analytical model* to evaluate the protocol performance *under mathematically tractable conditions*, by leveraging common simplifying assumptions to capture the MAC-layer dynamics; this model has been validated through simulations and was useful to get a first indication on the achievable gain. The second step aimed to increase the relevance of the work by demonstrating the general accordance between the theoretical findings of the analytical model and what we achieved through *extensive system-level simulations* in realistic and complex urban scenarios by accounting for physical layer phenomena (e.g., signal propagation counting for building obstructions) and real vehicle mobility. This second step was useful to go deeper into the effects of FD in highly interfered and dynamic environments, where hidden terminals could hinder the advantages of CD. Indeed, also in this case we found that CD still keeps its gain

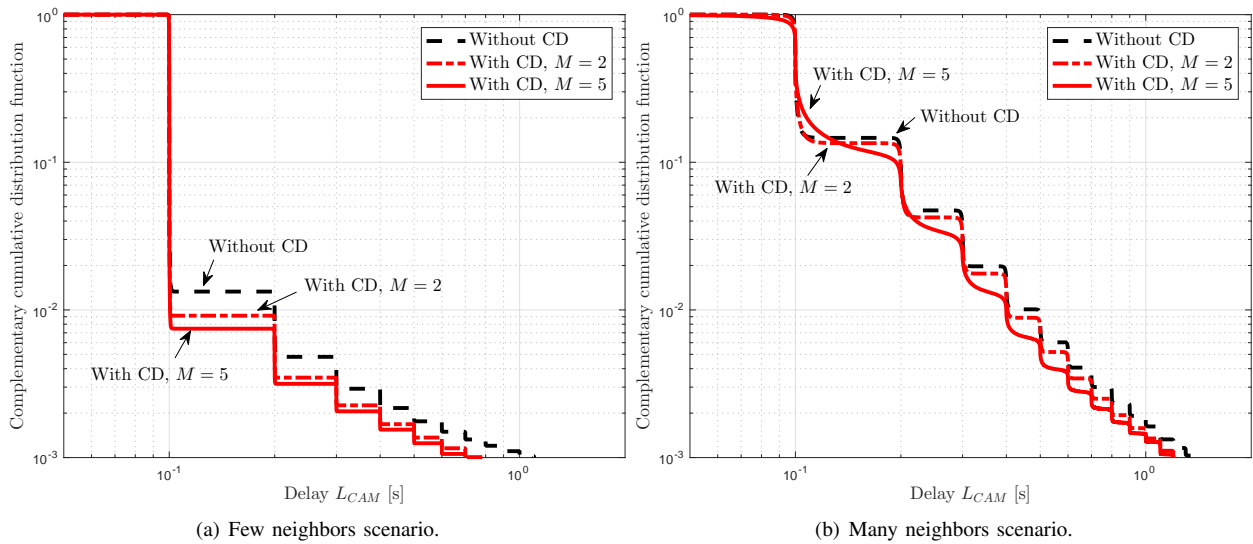

Fig. 12. Performance comparison with and without CD: CCDF of the update delay for vehicles that are less than 100 m from each other ( $M = 2, 5$ ,  $B_{CAM} = 400$  bytes,  $t_d = t_h$ ).

compared to a legacy half-duplex CSMA/CA, especially in high-density traffic conditions.

Improvements of the FD CSMA/CA are remarkable for broadcast especially (i) at short source-destination distances, where the successful reception is more crucial for cooperative safety applications, and (ii) under crowded traffic conditions, where the legacy IEEE 802.11 technology is well known to poorly perform with detrimental effects on throughput and latency of CAMs. The higher reliability achieved by FD, compared to the legacy HD solution, implies a reduction in the CAM update delay.

Parameters related to the specific CD implementation also affect the achieved performance. First, the number of retransmission attempts should be kept low under crowded channel conditions not to worsen congestion, whereas increasing retransmissions can bring some benefits under low-density scenarios. Second, a short detection time is proven to get the best of the CD capability, especially for long CAMs. Such findings confirm the early intuition in [15] and the expectation that FD will be a key factor to enable the evolution of vehicular applications towards automated driving in a dense network of vehicles exchanging periodic information-rich CAM messages.

Regarding future work, although both simulation and analytical results clearly show that FD is effective in handling direct collisions, it is however unable to tackle hidden terminals. Our proposal could hence be complemented with solutions handling hidden terminals specifically. In addition, instead of aborting a potentially colliding packet every time an impending collision is detected, the decision whether aborting an ongoing transmission or not could be made according to the inferred size of the neighborhood, tracked by receiving CAMs.

Finally, implementing the proposed technique requires minimal changes to the CSMA/CA design, since it keeps the basic MAC rules and does not require additional signaling and message passing. However, if FD is leveraged with all its features (e.g., including simultaneous bidirectional data exchange), further issues need to be addressed at the PHY

and the MAC layers, either separately or jointly, to manage the higher amount of interference generated by more nodes communicating simultaneously. Therefore, advanced signal processing at the receiver side is needed to learn the structure of the inter-user interference and cancel it.

## REFERENCES

- [1] C. Campolo, A. Molinaro, and R. Scopigno, "From today's VANETs to tomorrow's planning and the bets for the day after," *Elsevier Vehicular Communications*, vol. 2, no. 3, pp. 158–171, 2015.
- [2] ETSI EN 102 637-2 v1.3.1, "ITS; Vehicular Communications; Basic Set of Applications; Part 2: Specification of Cooperative Awareness Basic Service," 2014.
- [3] "IEEE Std. 802.11-2012: IEEE Standard for Information technology - Part 11: Wireless LAN Medium Access Control (MAC) and Physical Layer (PHY) Specifications," 2012.
- [4] M. Torrent-Moreno, D. Jiang, and H. Hartenstein, "Broadcast reception rates and effects of priority access in 802.11-based vehicular ad-hoc networks," in *Proc. of the 1st ACM Int. Workshop on Vehicular ad hoc networks*, 2004.
- [5] S. Eichler, "Performance evaluation of the IEEE 802.11p WAVE communication standard," in *IEEE VTC-2007 Fall*.
- [6] T. V. Nguyen, F. Baccelli, K. Zhu, S. Subramanian, and X. Wu, "A performance analysis of CSMA based broadcast protocol in VANETs," in *IEEE INFOCOM 2013*.
- [7] D. Kim, H. Lee, and D.-K. Hong, "A survey of in-band full-duplex transmission: From the perspective of PHY and MAC layers," *Communications Surveys and Tutorials, IEEE*, vol. 17, no. 4, pp. 2017–2046, 2015.
- [8] Y. Liao, T. Wang, L. Song, and Z. Han, "Listen-and-talk: protocol design and analysis for full-duplex cognitive radio networks," *IEEE Transactions on Vehicular Technology*, vol. 66, no. 1, pp. 656–667, 2017.
- [9] M. Jain, J. I. Choi, T. Kim, D. Bharadia, S. Seth, K. Srinivasan, P. Levis, S. Katti, and P. Sinha, "Practical, real-time, full duplex wireless," in *Proc. of the 17th annual Int. Conf. on Mobile computing and networking*, ACM, 2011.
- [10] W. Cheng, X. Zhang, and H. Zhang, "RTS/FCTS mechanism based full-duplex MAC protocol for wireless networks," in *IEEE GLOBECOM, 2013*, pp. 5017–5022.
- [11] R. Doost-Mohammady, Y. Naderi, and K. Chowdhury, "Performance analysis of CSMA/CA based medium access in full duplex wireless communications," *Transactions on Mobile Computing, IEEE*, vol. 15, no. 6, 2016.
- [12] R. Liao, B. Bellalta, and M. Oliver, "Modelling and enhancing full-duplex MAC for single-hop 802.11 wireless networks," *IEEE Wireless Communications Letters*, vol. 4, no. 4, pp. 349–352, 2015.

- [13] A. Bazzi, B. Masini, and A. Zanella, "Performance analysis of V2V beaconing using LTE in direct mode with full duplex radios," *Wireless Communications Letters, IEEE*, vol. 4, no. 6, pp. 685–688, 2015.
- [14] T. Yang, R. Zhang, X. Cheng, and L. Yang, "A graph coloring resource sharing scheme for full-duplex cellular-vanet heterogeneous networks," in *IEEE ICNC 2016*.
- [15] C. Campolo, A. Molinaro, and A. Berthet, "Improving CAMs broadcasting in VANETs through Full-Duplex Radios," in *IEEE PIMRC 2016*.
- [16] X. Xie and X. Zhang, "Does full-duplex double the capacity of wireless networks?" in *IEEE INFOCOM 2014*.
- [17] X. Wang, H. Huang, and T. Hwang, "On the capacity gain from full duplex communications in a large scale wireless network," *IEEE Transactions on Mobile Computing*, vol. 15, no. 9, pp. 2290–2303, Sept 2016.
- [18] K. M. Thilina, H. Tabassum, E. Hossain, and D. I. Kim, "Medium access control design for full duplex wireless systems: challenges and approaches," *IEEE Communications Magazine*, vol. 53, no. 5, pp. 112–120, 2015.
- [19] L. Wang, F. Tian, T. Svensson, D. Feng, M. Song, and S. Li, "Exploiting full duplex for device-to-device communications in heterogeneous networks," *IEEE Communications Magazine*, vol. 53, no. 5, pp. 146–152, 2015.
- [20] Z. Zhang, X. Chai, K. Long, A. V. Vasilakos, and L. Hanzo, "Full duplex techniques for 5G networks: self-interference cancellation, protocol design, and relay selection," *IEEE Communications Magazine*, vol. 53, no. 5, pp. 128–137, 2015.
- [21] A. Sahai, G. Patel, and A. Sabharwal, "Pushing the limits of full-duplex: Design and real-time implementation," *arXiv preprint arXiv:1107.0607*, 2011.
- [22] D. Korpi, J. Tamminen, M. Turunen, T. Huusari, Y. S. Choi, L. Anttila, S. Talwar, and M. Valkama, "Full-duplex mobile device: pushing the limits," *IEEE Communications Magazine*, vol. 54, no. 9, pp. 80–87, September 2016.
- [23] W. Choi, H. Lim, and A. Sabharwal, "Power-controlled medium access control protocol for full-duplex WiFi networks," *IEEE Transactions on Wireless Communications*, vol. 14, no. 7, pp. 3601–3613, 2015.
- [24] M. Duarte *et al.*, "Design and characterization of a full-duplex multi-antenna system for WiFi networks," *IEEE Trans. on Vehi. Technology*, vol. 63, no. 3, pp. 1160–1177, 2014.
- [25] D. Marlali and O. Gurbuz, "Design and performance analysis of a Full-Duplex MAC protocol for wireless local area networks," *Ad Hoc Networks*, vol. 67, pp. 53–67, 2017.
- [26] K.-h. Lee and J. Yoo, "Performance of the full-duplex MAC protocol in non-saturated conditions," *IEEE Communications Letters*, vol. 21, no. 8, pp. 1827–1830, 2017.
- [27] S. Goyal, P. Liu, O. Gurbuz, E. Erkip, and S. Panwar, "A distributed MAC protocol for full duplex radio," in *2013 Asilomar Conference on Signals, Systems and Computers*, pp. 788–792.
- [28] N. Singh, D. Gunawardena, A. Proutiere, B. Radunovi, H. V. Balan, and P. Key, "Efficient and fair MAC for wireless networks with self-interference cancellation," in *IEEE WiOpt 2011*.
- [29] M. Kontik and S. C. Ergen, "Distributed medium access control protocol for successive interference cancellation-based wireless ad hoc networks," *IEEE Communications Letters*, vol. 21, no. 2, pp. 354–357, 2017.
- [30] Y. Liao, K. Bian, L. Song, and Z. Han, "Full-duplex MAC protocol design and analysis," *Communications Letters, IEEE*, vol. 19, no. 7, pp. 1185–1188, 2015.
- [31] C. Campolo, A. Molinaro, A. O. Berthet, and A. Vinel, "Full-duplex radios for vehicular communications," *IEEE Communications Magazine*, vol. 55, no. 6, pp. 182–189, 2017.
- [32] F. Lehmann and A. Berthet, "A factor graph approach to digital self-interference mitigation in OFDM full-duplex systems," *IEEE Signal Processing Letters*, vol. 24, no. 3, pp. 344–348, 2017.
- [33] S. Subramanian *et al.*, "Congestion control for vehicular safety: synchronous and asynchronous MAC algorithms," in *ACM VANET*, 2012.
- [34] M. I. Hassan, H. L. Vu, and T. Sakurai, "Performance analysis of the IEEE 802.11 MAC protocol for DSRC safety applications," *IEEE Trans. on Vehi. Technology*, vol. 60, no. 8, pp. 3882–3896, Oct. 2011.
- [35] A. Bazzi, B. Masini, and A. Zanella, "Beaconing from connected vehicles: IEEE 802.11p vs. LTE-V2V," in *IEEE PIMRC 2016*.
- [36] Z. Tong, H. Lu, M. Haenggi, and C. Poellabauer, "A stochastic geometry approach to the modeling of DSRC for vehicular safety communication," *IEEE Transactions on Intelligent Transportation Systems*, vol. 17, no. 5, pp. 1448–1458, 2016.
- [37] X. Chen, H. H. Refai, and X. Ma, "A quantitative approach to evaluate DSRC highway inter-vehicle safety communication," in *IEEE GLOBE-COM 2007*, pp. 151–155.
- [38] W. Zhang, Y. Chen, Y. Yang, X. Wang, Y. Zhang, X. Hong, and G. Mao, "Multi-hop connectivity probability in infrastructure-based vehicular networks," *IEEE J. Sel. Areas Commun.*, vol. 30, no. 4, pp. 740–747, May 2012.
- [39] Y. Liao, T. Wang, L. Song, and Z. Han, "Listen-and-talk: Full-duplex cognitive radio networks," in *IEEE GLOBECOM 2014*, pp. 3068–3073.
- [40] Vissim. Accessed on October 2017. [Online]. Available: <http://vision-traffic.ptvgroup.com/en-us/products/ptv-vissim/>
- [41] A. Bazzi, G. Pasolini, and C. Gambetti, "SHINE: Simulation platform for heterogeneous interworking networks," in *IEEE ICC 2006*, vol. 12.
- [42] X. Wu *et al.*, "Vehicular communications using DSRC: challenges, enhancements, and evolution," *IEEE J. Sel. Areas Commun.*, vol. 31, no. 9, pp. 399–408, 2013.
- [43] D. Jiang, Q. Chen, and L. Delgrossi, "Optimal data rate selection for vehicle safety communications," in *ACM VANET 2008*, pp. 30–38.
- [44] J. Karedal, N. Czink, A. Paier, F. Tufvesson, and A. F. Molisch, "Path loss modeling for vehicle-to-vehicle communications," *IEEE Transactions on Vehicular Technology*, vol. 60, no. 1, pp. 323–328, Jan 2011.
- [45] C. Sommer, D. Eckhoff, R. German, and F. Dressler, "A computationally inexpensive empirical model of IEEE 802.11p radio shadowing in urban environments," in *WONS 2011*.
- [46] L. Cheng *et al.*, "Mobile vehicle-to-vehicle narrow-band channel measurement and characterization of the 5.9 GHz dedicated short range communication (DSRC) frequency band," *IEEE J. Sel. Areas Commun.*, vol. 25, no. 8, pp. 1501–1516, 2007.
- [47] C. F. Mecklenbrauker *et al.*, "Vehicular channel characterization and its implications for wireless system design and performance," *Proceedings of the IEEE*, vol. 99, no. 7, pp. 1189–1212, July 2011.
- [48] H. Seo, K. D. Lee, S. Yasukawa, Y. Peng, and P. Sartori, "LTE evolution for vehicle-to-everything services," *IEEE Communications Magazine*, vol. 54, no. 6, pp. 22–28, June 2016.



**Alessandro Bazzi** (S'03-M'06) received the Laurea degree and the Ph.D. degree in telecommunications engineering both from the University of Bologna, Italy, in 2002 and 2006, respectively. Since 2002, he works with the Institute of Electronics, Computer and Telecommunication Engineering (IEIT) of the National Research Council of Italy (CNR) and since the academic year 2006/2007, he has been acting as adjunct Professor at the University of Bologna. His work mainly focuses on connected vehicles and heterogeneous wireless access networks, with particular emphasis on medium access control, routing and radio resource management. Dr. Bazzi serves as a Reviewer and TPC Member for various international journals and conferences and he is currently in the Editorial Board of Hindawi's Mobile Information Systems.



**Claudia Campolo** is an assistant professor of Telecommunications at the University Mediterranea of Reggio Calabria, Italy. She received an M.S. degree in telecommunications engineering (2007) and a Ph.D. degree (2011) from the same university. She was a visiting Ph.D. student at Politecnico di Torino (2008) and a DAAD fellow at the University of Paderborn, Germany (2015). Her main research interests are in the field of vehicular networking and future Internet architectures.



**Barbara M. Masini** (S'02-M'05) received the Laurea degree (*summa cum laude*) in Telecommunications Engineering and the Ph.D. degree in Electronic, Computer Science, and Telecommunication engineering from the University of Bologna, Italy, in 2001 and 2005, respectively. Since 2005, she is a researcher at the Institute for Electronics and for Information and Telecommunications Engineering (IEIIT), of the National Research Council (CNR). Since 2006 she is also adjunct Professor at the University of Bologna. She works in the area of

wireless communication systems and her research interests are mainly focused on connected vehicles, from physical and MAC levels aspects up to applications and field trial implementations. Research is also focused on relay assisted communications, energy harvesting, and visible light communication (VLC). She is Editor of Elsevier Computer Communication, Guest Editor of Elsevier Ad Hoc Networks, Special Issue on Vehicular Networks for Mobile Crowd Sensing (2015), Mobile Information Systems, Special Issue on Connected Vehicles: Applications and Communication Challenges (2017), Sensors, Special Issue on Sensors Networks for Smart Roads (2018). She is Secretary of Chapter VT06/COM19 of the IEEE Italy section. She is TPC member of several conferences, reviewer for most international journals and for the Italian Ministry of Economic Development (MISE).



**Antonella Molinaro** is an associate professor of Telecommunications at the University Mediterranea of Reggio Calabria, Italy. She graduated in Computer Engineering (1991) at the University of Calabria, received a Master degree in Information Technology from CEFRIEL/Polytechnic of Milano (1992), and a Ph.D. degree in Multimedia Technologies and Communications Systems (1996). She was with the University of Messina (1998-2001) and the University of Calabria (2001-2004) as an assistant professor;

with the Polytechnic of Milano as a research fellow (1997-1998); and with Siemens A.G., Munich, Germany as a CEC fellow in the RACE-II program (1994-1995). In 2017 she was visiting professor at the Laboratory of Signals and Systems (L2S) of CNRS-CentraleSupélec-University Paris Sud. Her research activity mainly focuses on wireless and mobile networking, vehicular networks, information-centric networking.



**Alberto Zanella** (S'99-M'00-SM'12) received the Laurea degree (*summa cum laude*) in Electronic Engineering from the University of Ferrara, Italy, in 1996, and the Ph.D. degree in Electronic Engineering and Computer Science from the University of Bologna in 2000. In 2001 he joined the CNR-CSITE (merged in CNR-IEIIT since 2002) as a researcher and, since 2006, as senior researcher. His research interests include MIMO, mobile radio systems, ad hoc and sensor networks, vehicular networks. Since 2001 he has the appointment of Adjunct Professor of

Electrical Communication (2001 - 2005), Telecommunication Systems (2002-2012-2013), Multimedia Communication Systems (2006 - 2011) at the University of Bologna. He participated/participate to several national and European projects. He was Technical Co-Chair of the PHY track of the IEEE conference WCNC 2009 and of the Wireless Communications Symposium (WCS) of IEEE Globecom 2009. He was/is in the Technical Program Committee of several international conferences, such as ICC, Globecom, WCNC, PIMRC, VTC. He had served as Editor for Wireless Systems (2003-2012), IEEE TRANSACTIONS ON COMMUNICATIONS, and he is currently Senior Editor for the same journal.



**Antoine O. Berthet** is a Full Professor at CentraleSupélec, Gif-sur-Yvette, France, and a CNRS researcher. He received the Engineer's degree from Télécom SudParis, Evry, France, in 1997, the M.Sc. degree in signal processing from Télécom ParisTech, France, in 1997, the Ph.D. degree in computer science, electronics, and telecommunications from the University Pierre et Marie Curie (UPMC), Paris, France, in 2001, the Ph.D. degree in computer science from Télécom ParisTech in 2001, and the HDR degree from UPMC in 2007. From January

1998 to October 2000, he was with France Telecom R&D. From October 2000 to October 2001, he joined Alcatel Space Industries as a Senior Research Engineer and worked on high data rate modem design for satellites. Since 2001, he has been with Supélec (now CentraleSupélec). His research work is based on information theory, coding theory, and signal processing for telecommunications, with application to the physical layers of satellite, cellular, and vehicular networks.