



Università degli Studi Mediterranea di Reggio Calabria
Archivio Istituzionale dei prodotti della ricerca

A self-built shelter in wood and agglomerated cork panels for temporary use in Mediterranean climate areas

This is the peer reviewed version of the following article:

Original

A self-built shelter in wood and agglomerated cork panels for temporary use in Mediterranean climate areas / Barreca, F., Tirella, V.. - In: ENERGY AND BUILDINGS. - ISSN 0378-7788. - 142:(2017), pp. 1-7. [10.1016/j.enbuild.2017.03.003]

Availability:

This version is available at: <https://hdl.handle.net/20.500.12318/1709> since: 2020-11-30T18:26:15Z

Published

DOI: <http://doi.org/10.1016/j.enbuild.2017.03.003>

The final published version is available online at: <https://www.sciencedirect.com>.

Terms of use:

The terms and conditions for the reuse of this version of the manuscript are specified in the publishing policy. For all terms of use and more information see the publisher's website

Publisher copyright

This item was downloaded from IRIS Università Mediterranea di Reggio Calabria (<https://iris.unirc.it/>) When citing, please refer to the published version.

(Article begins on next page)

This is the peer reviewed version of the following article

Francesco Barreca, Viviana Tirella, A self-built shelter in wood and agglomerated cork panels for temporary use in Mediterranean climate areas, *Energy and Buildings*, Volume 142, 2017, Pages 1-7, ISSN 0378-7788

<https://doi.org/10.1016/j.enbuild.2017.03.003>.

(<https://www.sciencedirect.com/science/article/pii/S0378778816320291>)

The terms and conditions for the reuse of this version of the manuscript are specified in the publishing policy. For all terms of use and more information see the publisher's website.

A self-built shelter in wood and agglomerated cork panels for temporary use in Mediterranean climate areas

Francesco Barreca*, Viviana Tirella

Università degli studi Mediterranea di Reggio Calabria, Dipartimento di Agraria, Italy

ABSTRACT

In recent years, the situation of migrants seeking protection in Europe has grown exponentially since 2013. In Italy, the greatest difficulty is related to landings. Over 170,000 people registered on the coast of southern Italy in 2014. In emergency situations, it is necessary to ensure shelter and medical care to everybody. Many centres are makeshift structures, such as old houses or hotels, which are difficult to manage and entail elevated costs. The shelter prototype can be used for humanitarian emergencies or post-disaster reconstruction projects but also for tourism purposes, in highly naturalistic environments, or for seasonal agricultural workers. The objective of this paper is to propose a prototype of a building module, composed of wood and multilayer agglomerated cork panels, as an environmentally sustainable shelter that can be assembled on any terrain. It takes advantage of the characteristics of cork, such as acoustic and thermal insulation, fire resistance, natural origin, resistance to moulds and microorganisms, and shows high thermal performance. It can be built in different geometries and volumes and not necessarily by skilled workers.

1. Introduction

In recent years, the demand for temporary buildings has considerably increased, also due to the European migrant crisis. A total of

3.8 million people immigrated to one of the 28 EU Member States in 2014, while at least 2.8 million emigrants were reported to have left an EU Member State. Germany reported the largest total number of immigrants in 2014, followed by the United Kingdom, France, Spain and Italy [1]. The figures of emergency: 686 landings since the beginning of 2015; 116,127 migrants' arrivals in Italy in the last eight months (Fig. 1). The host system is saturated and the Government is looking for twenty thousand new houses [2].

A temporary shelter may be a solution to the increasing demand for accommodation and may ensure a house to everybody. Furthermore, the elevated operating cost may be paid off by the high performance casing. Global sustainability is ensured in all the stages of the product's life, from cradle to grave: in the choice of materials, the ease of installation, the energy consumption during life, and the environmental impact of disposal. The objective of this paper is to propose a prototype of a building module as an environmentally sustainable shelter that can be assembled on any terrain. Indeed, the shelter can be used for rural tourism, which is a growing opportunity for development if it is able to meet the emerging tourism demand. Green tourism is a type of tourism promoted by operators who pay special attention to the relationship between tourist activity and nature, adopting operational strategies in a spirit of harmony and respect [3]. Moreover, modular architecture has been developed from human ergonomic factors, since man is the primary user of the designed space [4]. In this particular case, the possibility to transport structural elements on a truck, or inside a container, dictated modularity. In fact, owing to its modularity, the piece is easy to handle and can be assembled by only a few workers. It is important that a device can be easily assembled directly by the local (not specialized) workforce, and it is equally important not to use cranes to lift the structure, considering that the prototype is designed to be used in agricultural areas, which are not always easily accessible by work-site vehicles. After examining the state of the art in modularity, the prototype was built to comply with the following requirements:

- Easy transport and assembly;

- Limited size and weight of the pieces so that they can be assembled and easily handled by one man, without any special equipment or vehicle;
- Clean and simple construction site that requires neither connections nor special cuts to be made only by skilled workers;

- Intuitive and fast assembly, which can be carried out by local workforce;
- Adaptability of the module to different terrains and units;
- Repeatability of the basic module in order to obtain different spatiality as requested.

2. Materials and methods

The prototype of the building module was made of wood and cork. Italy, along with Portugal, Algeria, Spain, Morocco, France and Tunisia, is the principal country exporting cork [5]. Cork trees occupy approximately 2.5 million hectares in large areas situated west of the Mediterranean basin [6,7] and on the Atlantic coast. The commerce of cork is environmentally friendly because, after harvesting, cork oak trees renew themselves; as a consequence, not a single tree is cut down. Its controlled use is not a threat for natural plantations. If forests maintain their economic value, people care for them, reducing the risk of fire and desertification. The cork oak tree has an average life span of 250–300 years. The cork bark is first stripped when the tree is 20 years old. After 9 years, it is possible to harvest the layer which has grown. Skilled workers pick up strips of cork bark without any harm to the tree. Cork is completely natural, renewable and recyclable. Furthermore, cork oak trees are fundamental in the process of protecting the planet from global warming: cork oak trees produce and release oxygen through photosynthesis and trap CO₂. The Mediterranean cork oak trees absorb 14 million tons of CO₂ every year [8]. The building industry uses cork for thermal and/or acoustic insulation, but also for elastic and anti-vibration expansion joints in major infrastructures. Cork is commonly used in the form of granules, which are mixed with lime for plaster, or of panels. Recently, it has been used to make inserts in porous, perforated bricks for curtain walls. In their studies on the thermal analysis of Egyptian perforated masonry red bricks, Bassiouny et al. showed that filling the holes with a low-thermal conductivity material, such as the polyurethane foam or cork, significantly increased the thermal resistance in the path of heat flow [9]. Thanks to the curtain panel of the shelter prototype, which is a multilayer agglomerated cork panel of recycled cork, and to its structure, which is made of wood, the entire shelter is a high example of fully recyclable bio-building structure. holes with a low-thermal conductivity material, such as the polyurethane foam or cork, significantly increased the thermal resistance in the path of heat flow [9]. Thanks to the curtain panel of the shelter prototype, which is a multilayer agglomerated cork panel of recycled cork, and to its structure, which is made of wood, the entire shelter is a high example of fully recyclable bio-building structure.

2.1. Description of the structure

The structure was designed as a timber frame [10]. A succession of “wooden portals”, composed of spruce boards hinged together, allow flexibility and modularity to the structure. The frame of the modular structure is made of 3 cm-thick and 16 cm-wide spruce boards and of columns of the same size as the horizontal beams in roofing and basement. This solution allows full interchangeability of the elements and contains the production costs of the prototype. There are systems for anchoring and stretching the tie rods at the nodes that connect the elements of the wooden portal, in order to brace the entire building module in the longitudinal direction. The wooden structure has a 3-cm 16-cm T-cross-section to block the multilayer agglomerated cork panels (Fig. 2).

It is possible to build a modular unit by repeating the assembling procedure for any number of times. Thus, it is even possible to build a 3 m × 5 m shelter of 3 m of height.

2.2. The curtain panels

The walls of the shelter are made of multilayer agglomerated cork panels. Cork is a hypoallergenic, insulating, mould, microorganisms- and fire-resistant material. No synthetic material can replicate its properties, which are the result of its flexible cell membrane and of its honeycombed structure [5]. Our solution of a multilayer agglomerated cork panel aims at fostering the use of this material in the building industry. In order to create a multi-layer agglomerated cork panel, it is necessary to reinforce the cork sheet using an inner core structure, which, in this case, was made of OSB. (Oriented Strand Board). Cork sheets are made of different cork grain size. In order to obtain effective protection from adverse external weather conditions, especially in relation to the typical high temperatures of the summer season in southern Italy, the walls were designed to achieve an adequate specific thermal capacity. This is a particularly significant thermophysical parameter for insulating materials because, together with density and thermal conductivity, it enables to calculate the thermal diffusivity of the material, i.e. the rate at which the indoor temperature changes when exposed to a temperature difference across the material [11]. Studies on the thermal insulation performance assessment of agglomerated cork boards in Mediterranean climate areas [12] demonstrate that agglomerated cork boards have thermophysical characteristics similar to those of natural cork (Table 1).

The multilayer agglomerated cork board was designed by evaluating the dynamic behaviour of the thermal properties of the layers. The method used complies with ISO 13786:2007, which provides for a simplified method for calculating the heat capacity of building components made up of layers of homogeneous materials. The above-mentioned thermal properties are required for the evaluation of the energy performance of the building envelope. The multilayer agglomerated cork board has a double inner gap, which allows lodging any kind of plant for the shelter, and an inner core of 1 cm-thick OSB, or of other bio-particle boards [13]. The cork sheets are secured to OSB by wooden spacer laths placed at a distance of about 30 cm from each other. The definitive thicknesses of the layers were calculated for successive iterations according to ISO 13786:2007 in order to obtain a value of the thermal time shift (τ) of the wall greater than 6 h, thereby obtaining a total thickness of the multilayer agglomerated cork board of 19 cm (Fig. 3).

Therefore, the multilayer agglomerated cork panels have a section of 19 cm, which is composed as follows: 6 cm-thick cork sheet, 3 cm 3 cm wooden spacer laths, 1 cm-thick OSB inner core, 3 cm closed air cavity and another 6 cm-thick cork sheet.

The thermophysical parameters of the wall were calculated according to UNI EN ISO 13786 (Table 2):

The walls and the roof of the shelter were built using multilayer agglomerated cork panels fitted without mortar. The multilayer agglomerated cork panels have a size of 90 cm 90 cm and a thickness of 19 cm; these dimensions allow keeping the weight of the partition below 20 kg, which ensures one worker can handle a piece in the assembling phase. The inner core and the wooden spacer

laths were designed to fit into the same upper or lower panel in order to form the infill element of the building module. Continuity was ensured by the external layer of the panel, which had a size of 90 cm 93 cm and partially overlapped the wooden structure. That improved the performance of cork sheets limiting thermal bridges and made the exterior of the prototype more pleasant and uniform. To improve the mechanical performance of the multilayer agglomerated cork panel, the wooden spacer laths were laid horizontally by placing them sideways to the spruce structure.

2.3. Analysis of the prototype

In order to verify the sustainability of the proposed shelter prototype, an analysis of the energy and of the thermal comfort, which can be guaranteed during the year, was carried out. There are many different types of software to analyse thermophysical characteristics of buildings, such as Energy+ and Trnsys, or eQuest [14]. In this study, the analysis was conducted with Design Builder and Energy+ software programmes in order to obtain the annual

dynamic simulation of temperature and irradiance as well as to analyse the shelter thermal performance. After modelling the pro- totype in Design Builder (Fig. 4) the layers of the construction and its parameters were set (Table 3).

Then, activity template was set as Dwell Domestic Bedroom: an area primarily used for sleep, with no machinery or device. The modelled shelter was oriented North-South in Reggio Calabria and only solar and internal gains from occupants were considered in the cooling design calculation. The annual simulation analysis was started using a daily interval. The following are the results (Fig. 5):

The annual simulation analysis confirmed the high performance of cork walls. Finally, the entire self-built shelter prototype was built.

3. Results and discussion

The encouraging results obtained from the thermal analysis of the shelter led to the construction of a full-scale prototype. The assembly of the prototype, which was about 3 m × 5 m by 3 m of height, proved to be simple due to its modularity, to the inter- changeability of its components, to the structure of the panels and to the simplicity of the dry-links (Fig. 6). The construction of the prototype involved 3 workers and was carried out in 6-h time.

The shelter prototype was monitored with the Thermal Micro- climate HD32.3 Instrument by Delta Ohm. This instrument can

detect Ambient Temperature [$^{\circ}$ C] and other environmental indoor

conditions. The measurement time interval was set to 15 min. Extensive meteorological data were available from an on-site weather station, which was located on the roof of Mediterranea University of Reggio Calabria, near the shelter (Figs. 7 and 8).

The monitored shelter was not occupied and all openings stayed closed during the monitoring period.

Measurements were carried out during the months of February, March, April, and July. The extreme max and min temperatures, which are reported in Figs. 9 and 10, were recorded in April and July. The measurements of the indoor and outdoor temperature of the prototype were com- pared in order to obtain time shift t .

The resulting time shift t was 3 h 45 min. Thanks to the properties of cork, indoor temperature was 24° C while outdoor temperature was 28° C. The experimentally observed values of the

time shift between indoor and outdoor temperature confirmed the values calculated by applying the ISO 13786 (Table 2). In particular, the time shift of the temperature on the outer and inner faces of the multilayer agglomerated cork panel was inevitably balanced by convective motion and infiltration of air from the inside, which reduced the value. Air transfers from outside into the shelter, internal convective motion and radiation tended to mitigate the difference of temperature between the faces of the partition, which was sufficient to guarantee acceptable welfare conditions in the living module, especially under warm conditions. A comparison of different building partitions of the shelter was carried out in order to determine different performances using the same volume, geographic location and function. Particularly, a 29.4 cm-thick partition in brick block with transmittance $U = 0.351$ [$W m^{-2} K^{-1}$], and a 6.9 cm-thick metallic partition with transmittance $U = 2.547$ [$W m^{-2} K^{-1}$] were considered. The following diagram shows the elements of the shelter used to start the simulation in the Design Builder software (Fig. 10): The chart provides a comparison of the different performance of partitions obtained by annual simulation using Design Builder (Fig. 11). T (Outdoor Temperature) was compared with T_a (Ambient Temperature) of the shelters with Wood/Cork, Brick/block and Metal Cladding partitions. The result was clear: in the coldest period, from October to March, T_a of the shelter with Metal Cladding partitions was nearest T Outdoor Temperature; then, there was the T_a line of the shelter with Brick/Block partitions and, on top, there was the T_a line of the shelter prototype, the warmest one (from 9° C of T up to 16° C of T_a of the shelter). On the contrary, during the hottest period, from March to September, T Outdoor Temperature was 29° C, while T_a of the shelter with Metal cladding partitions was 30° C, T_a of the shelter with Brick/block partitions was 27° C, and T_a of the shelter prototype was 26° C.

4. Conclusion

The dynamic simulation with Design Builder and the comparison between a shelter in brick or in steel demonstrated that the wood-cork shelter had a better performance in all seasons, especially in hot climate. From March to September, the maximum air temperature inside the wood-cork shelter was 26 °C, 3 °C less than the outdoor air temperature and 1 °C less than the air temperature inside the brick shelter, which, however had 30 cm-thick walls, one third thicker than those of the wood-cork shelter. Anyway, the most interesting result was the temperature time shift, which was about 4 h, an important performance that guarantees good indoor conditions for the dweller's welfare in the hottest season. The assembly was very easy and fast; it was done completely in dry and every structural component was interchangeable. The particular solution adopted for the floor made a full levelling of terrain unnecessary, because it was possible to use screw piles under the wood portals. The modularity of the multilayer agglomerated cork panels allows choosing or changing the position of the openings and varying the development in length of the shelter. These characteristics make the modular unit usable not only for emergency housing but also for temporary shelter in highly environmentally fragile areas, due to the materials and manufacturing solutions adopted that make it a high-sustainability module. Moreover, this module may also be used for the construction of an animal breeding shelter or for semi-wild herds in a protected area. The assembly of the shelter does not require skilled workers and the multilayer agglomerated cork panels may be made by using recycled cork sheets. The particular configuration allows the production of building modules in the outdoor air temperature and 1 °C less than the air temperature inside the brick shelter, which, however had 30 cm-thick walls, one third thicker than those of the wood-cork shelter. Anyway, the most interesting result was the temperature time shift, which was about 4 h, an important performance that guarantees good indoor conditions for the dweller's welfare in the hottest season. The assembly was very easy and fast; it was done completely in dry and every structural component was interchangeable. The particular solution adopted for the floor made a full levelling of terrain unnecessary, because it was possible to use screw piles under the wood portals. The modularity of the multilayer agglomerated cork panels allows choosing or changing the position of the openings and varying the development in length of the shelter. These characteristics make the modular unit usable not only for emergency housing but also for temporary shelter in highly environmentally fragile areas, due to the materials and manufacturing solutions adopted that make it a high-sustainability module. Moreover, this module may also be used for the construction of an animal breeding shelter or for semi-wild herds in a protected area. The assembly of the shelter does not require skilled workers and the multilayer agglomerated cork panels may be made by using recycled cork sheets. The particular configuration allows the production of building modules in series and the widespread use of the proposed solution. It could also lead to the design of variant solutions with the same structural elements. This building could represent an original way to improve environmentally sustainable temporary architecture as well as to have cheap and comfortable accommodation also in emergency situations.

Acknowledgment

The research activity illustrated in this paper was funded by the Region Calabria within the project PSR (Rural Development Programme) 2007/2013 Measure 124 – Aid application n.94752170756 – project SUBERWALL.

References

- [1] Eurostat, Eurostat Statistics Explained, 2016, Available: [http://ec.europa.eu/eurostat/statistics-explained/index.php/Migration and migrant population statistics](http://ec.europa.eu/eurostat/statistics-explained/index.php/Migration_and_migrant_population_statistics) [Online].
- [2] Ministero dell'Interno, Interno.it, 2016, Available in: www.interno.gov.it [Online].
- [3] F. D'Alessandro, Green Building for a Green Tourism. A new model of eco-friendly agritourism, Agric. Agric. Sci. Proc. 8 (2016) 201–210.

- [4] C. Masotti, *Manuale di Architettura di emergenza e temporanea*, Sistemi Editoriali SE, Casoria (NA), 2010.
- [5] Cancork Floor Inc, Cancork Floor Inc., 2008, Available in: <https://cancork.com/about-cork-forna.html> [Online].
- [6] G. Modica, F. Solano, A. Merlino, S. Di Fazio, F. Barreca, L. Laudari, C.R. Fichera, Using Landsat 8 imagery in detecting cork oak (*Quercus suber* L.) woodlands: a case-study in Calabria (Italy), *J. Agric. Eng.* XLVI (2016) 205.
- [7] A.R. Proto, G. Zimbalatti, Firewood cable extraction in the southern Mediterranean area of Italy, *For. Sci. Technol.* 12 (1) (2016) 16–23.
- [8] Sugheronaturale, *L'importanza delle foreste di sughero per l'equilibrio ambientale*, 2015, Available in: <http://www.sugheronaturale.it> [Online].
- [9] R. Bassiouny, M.R. Ali, E.-S.H. NourEldeen, Modeling the thermal behavior of egyptian perforated masonry red brick filled with material of low thermal conductivity, *J. Build. Eng.* 5 (2016) 158–164.
- [10] G. Sherwood, R.C. Stroh, *Wood Frame House Construction: A Do-it-yourself Guide*, Sterling Publishing Co., Inc., New York, 1992.
- [11] F. Barreca, C.R. Fichera, Thermal insulation performance assessment of agglomerated cork boards, *Wood Fiber Sci.* (2016) 1–8.
- [12] F. Barreca, C.R. Fichera, Thermal insulating characteristics of cork agglomerate panels in sustainable food buildings, *CEUR Workshop Proceedings* 1498 358366 (2015).
- [13] J.-A. Flores-Yepes, J.J. Pastor Perez, F.-J. Gimeno-Blanes, I. Rodriguez-Guisado, M.-J. Frutos-Fernandez, Full recovery of Arundo donax particleboard from swelling test whitout waterproofing additives, *BioResources* (2012) 5222–5235.
- [14] D.B. Crawley, J.W. Hand, M. Kummert, B.T. Griffith, Contrasting the capabilities of building energy performance simulation programs, *Build. Environ.* 43 (April (4)) (2008) 661–673.

Fig. 1. Trend of migrants' arrivals on the Italian coasts between 2011 and 2014.

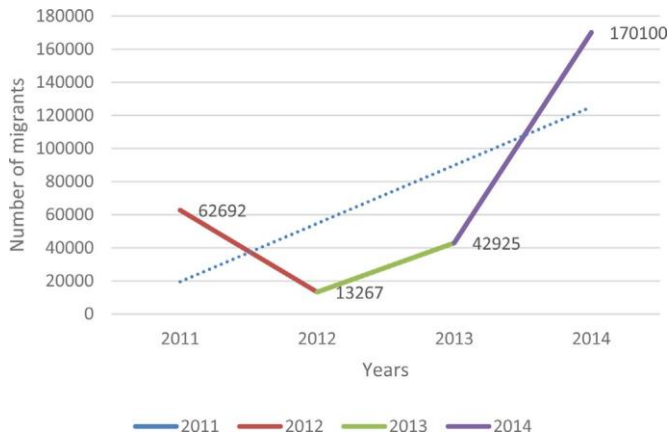

a. Description of the structure

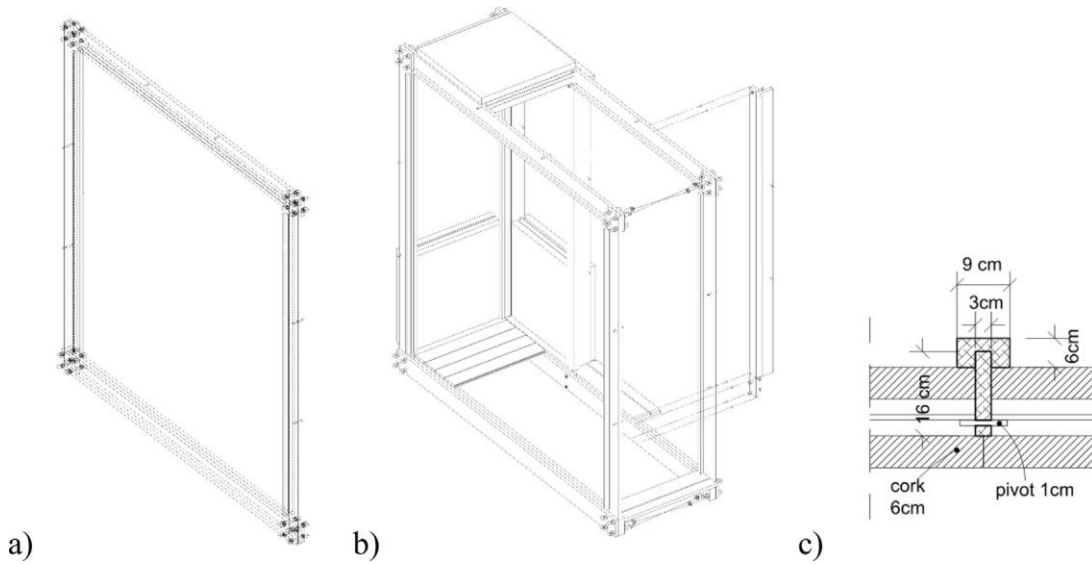

Fig. 2. The structure of the shelter prototype: (a) wooden portal, (b) single module of the shelter, (c) section of spruce structure.

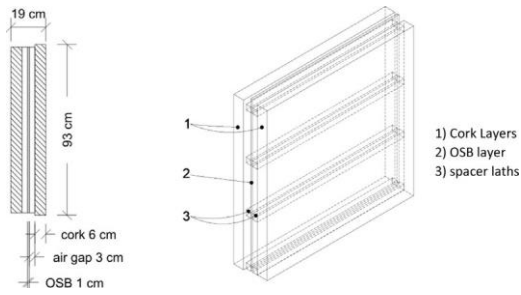

Fig. 3. The multilayer agglomerated cork panel.

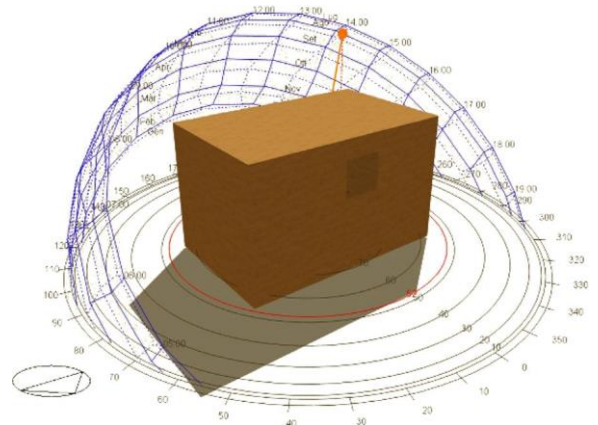

Fig. 4. Modelling the shelter prototype in Design Builder.

Table 1
Properties of agglomerated cork boards.

Properties	Value
Bulk density [kg m^{-3}]	145.85
Mean cork dia [m] $\cdot 10^{-3}$	3.02
Conductance [$\text{W m}^{-2} \text{K}^{-1}$]	2.52
Conductivity [$\text{W m}^{-1} \text{K}^{-1}$] $\cdot 10^{-1}$	0.52
Specific heat capacity [$\text{J K}^{-1} \text{kg}^{-1}$]	2491.90
Diffusivity [$\text{m}^2 \text{s}^{-1}$] $\cdot 10^{-8}$	9.38
Emissivity	0.94

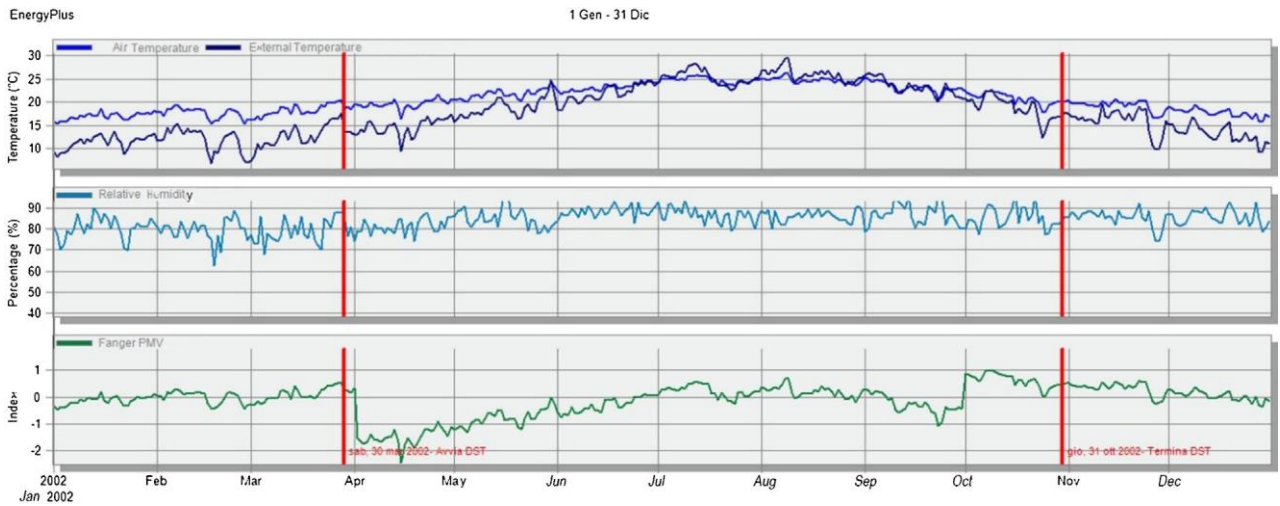

Fig. 5. Annual simulation analysis of air temperature and outside dry-bulb temperature; Humidity; PMV.

Table 2
Parameters of the wall according to UNI EN ISO 13786.

Properties	Value
Periodic thermal transmittance Y_{mn} [$W m^{-2} K^{-1}$]	0.18
Thermal time shift Dt [h]	6.71
Thermal admittance (external side) Y_{mm} [$W m^{-2} K^{-1}$]	1.13
Thermal admittance (internal side) Y_{mm} [$W m^{-2} K^{-1}$]	1.05
Internal areal heat capacity k [$kJ m^{-2} K^{-1}$]	18.30
External areal heat capacity k [$kJ m^{-2} K^{-1}$]	18.30
Conductivity [$W m^{-1} K^{-1}$]	0.06954
Specific heat [$J kg^{-1} K^{-1}$]	795.65
Density [$kg m^{-3}$]	121.05

Table 3
Multilayer agglomerated cork panel parameters.

Parameters	Value
<i>Inner surface</i>	
Convective heat transfer coefficient [$W m^{-2} K^{-1}$]	2.793
Radiative heat transfer coefficient [$W m^{-2} K^{-1}$]	5.540
Surface resistance [$m^2 KW^{-1}$]	0.120

Outer surface

Convective heat transfer coefficient [$W m^{-2} K^{-1}$]	27.793
Radiative heat transfer coefficient [$W m^{-2} K^{-1}$]	5.540
Surface resistance [$m^2 KW^{-1}$]	0.030

With bridging (BS EN ISO 6946)

Thickness (cm)	19
Internal heat capacity [$kJ m^{-2} K^{-1}$]	9.6313
Upper resistance limit [$m^2 KW^{-1}$]	2.884
Lower resistance limit [$m^2 KW^{-1}$]	2.884
U value surface to surface [$W m^{-2} K^{-1}$]	0.366
R value [$W m^{-2} K^{-1}$]	2.884
U value [$W m^{-2} K^{-1}$]	0.347



Fig. 6. Construction of the shelter prototype.



Fig. 7. Site of weather measurements at the University of Reggio Calabria and environmental sensor system inside the shelter prototype.

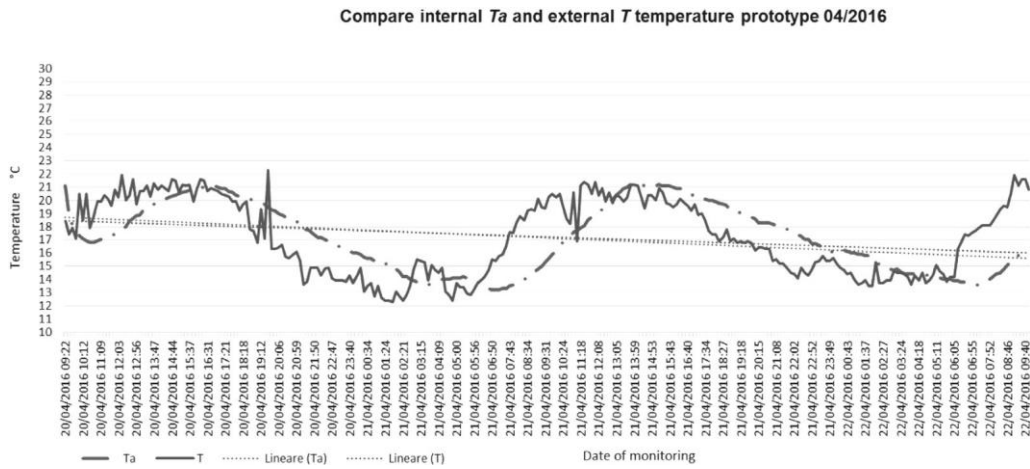

Fig. 8. (T_a) indoor air temperature of the shelter, (T) outdoor temperature measured in April.

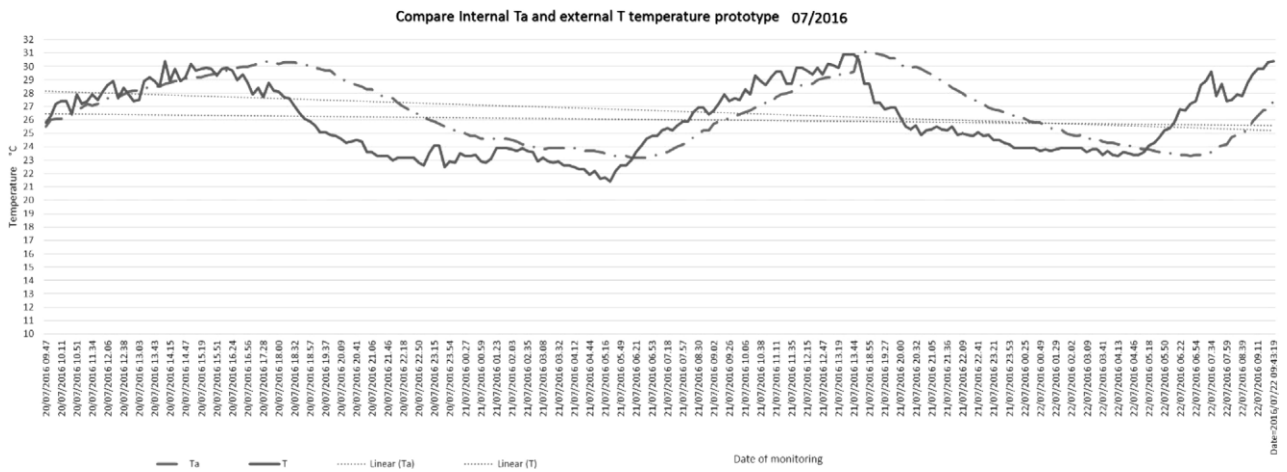

Fig. 9. Indoor air temperature of the shelter, (T) outdoor temperature measured in July.









	Shelter of Wood/Cork	Brick/block	Metal cladding
Flat roof	 <p>Thickness: 19 cm Heat Capacity: 9.63 kJ·m⁻²·K⁻¹ Transmittance: 0.348 W·m⁻²·k⁻¹</p>	 <p>Thickness: 15 cm Heat Capacity: 4.9 kJ·m⁻²·K⁻¹ Transmittance: 0.252 W·m⁻²·k⁻¹</p>	 <p>Thickness: 13.2 cm Heat Capacity: 32.61 kJ·m⁻²·K⁻¹ Transmittance: 2.505 W·m⁻²·k⁻¹</p>
Wall	 <p>Thickness: 19 cm Heat Capacity: 9.63 kJ·m⁻²·K⁻¹ Transmittance: 0.348 W·m⁻²·k⁻¹</p>	 <p>Thickness: 29.4 cm Heat Capacity: 134 kJ·m⁻²·K⁻¹ Transmittance: 0.351 W·m⁻²·k⁻¹</p>	 <p>Thickness: 6.9 cm Heat Capacity: 11.7 kJ·m⁻²·K⁻¹ Transmittance: 2.547 W·m⁻²·k⁻¹</p>
Floor	 <p>Thickness: 3 cm Heat Capacity: 34.19 kJ·m⁻²·K⁻¹ Transmittance U: 1.505 W·m⁻²·k⁻¹</p>	 <p>Thickness: 10 cm Heat Capacity: 88.2 kJ·m⁻²·K⁻¹ Transmittance: 2.929 W·m⁻²·k⁻¹</p>	 <p>Thickness: 10 cm Heat Capacity: 88.2 kJ·m⁻²·K⁻¹ Transmittance: 2.929 W·m⁻²·k⁻¹</p>

Fig. 10. Comparison between the different hypotheses of shelter partition.

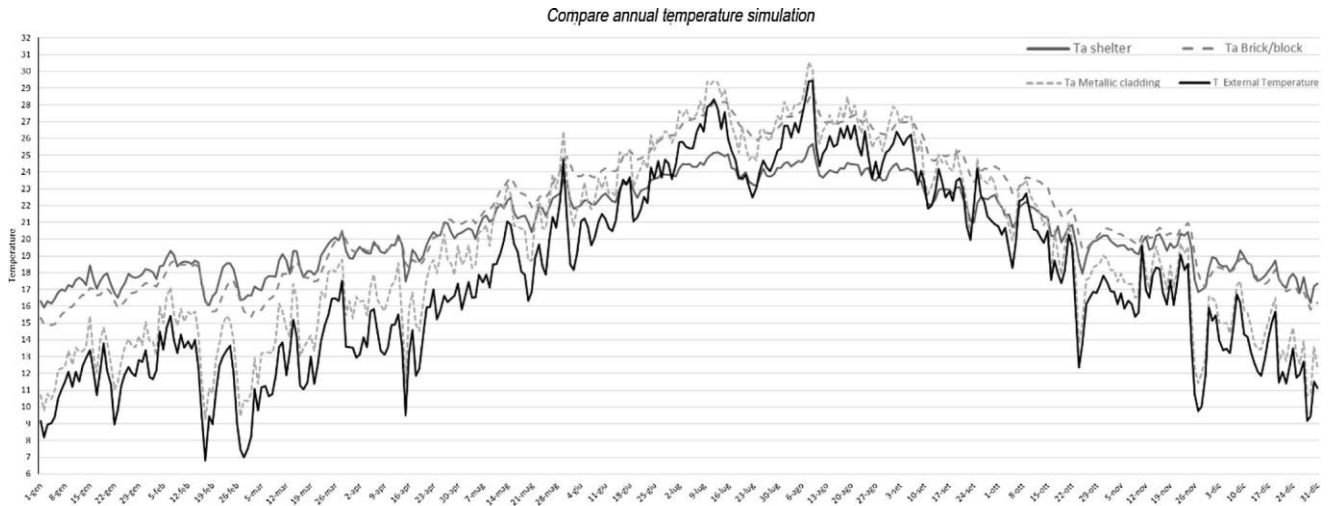

Fig. 11. Compare (T_a) measured ambient temperature of the Wood/Cork shelter with (T_a) of the shelters with Brick/block and Metal Cladding partitions, and with (T) outdoor temperature