



Università degli Studi Mediterranea di Reggio Calabria
Archivio Istituzionale dei prodotti della ricerca

A Smart Power Meter to Monitor Energy Flow in Smart Grids: The Role of Advanced Sensing and IoT in the Electric Grid of the Future

This is the peer reviewed version of the following article:

Original

A Smart Power Meter to Monitor Energy Flow in Smart Grids: The Role of Advanced Sensing and IoT in the Electric Grid of the Future / Morello, R., Fulco, G., Mukhopadhyay, S.C., De Capua, C.. - In: IEEE SENSORS JOURNAL. - ISSN 1530-437X. - 17:23(2017), pp. 7828-7837. [10.1109/JSEN.2017.2760014]

Availability:

This version is available at: <https://hdl.handle.net/20.500.12318/5868> since: 2022-06-15T12:03:45Z

Published

DOI: <http://doi.org/10.1109/JSEN.2017.2760014>

The final published version is available online at: <http://ieeexplore.ieee.org/document/8059770/>

Terms of use:

The terms and conditions for the reuse of this version of the manuscript are specified in the publishing policy. For all terms of use and more information see the publisher's website

Publisher copyright

This item was downloaded from IRIS Università Mediterranea di Reggio Calabria (<https://iris.unirc.it/>) When citing, please refer to the published version.

(Article begins on next page)

A Smart Power Meter to Monitor Energy Flow in Smart Grids:

The Role of Advanced Sensing and IoT in the Electric Grid of the Future

R. Morello, *Member, IEEE*, C. De Capua, *Member, IEEE*, G. Fulco, S.C. Mukhopadhyay, *Fellow, IEEE*

Abstract— This paper aims to describe the role of advanced sensing systems in the electric grid of the future. In detail the project, development and experimental validation of a smart power meter are described in the following. The authors provide an outline of the potentialities of the sensing systems and IoT to monitor efficiently the energy flow among nodes of electric network. The described power meter uses the metrics proposed in the IEEE Standard 1459-2010 to analyse and process voltage and current signals. Information concerning the power consumption and power quality could allow the power grid to route efficiently the energy by means of more suitable decision criteria. The new scenario has changed the way to exchange energy in the grid. Now energy flow must be able to change its direction according to needs. Energy cannot be now routed by considering just only the criterion based on the simple shortening of transmission path. So, even energy coming from a far node should be preferred if it has higher quality standards. In this view, the proposed smart power meter intends to support the smart power grid to monitor electricity among different nodes in an efficient and effective way.

Index Terms— Electric grid, smart grid, sensing systems, smart power meter, IoT.

I. INTRODUCTION

IN the power grid of the future, sensors and transducers will have a significant role to monitor energy in real time according to demand. Smart sensing systems can provide new opportunities for automatic power measurement and data processing so to take decisions in real time.

The electric network is a complex and interconnected system commonly called grid. Growing electricity demand needs more sustainable energy generation by renewable sources. Today, we are observing a radical transformation of the public electric system. For example, energy flow becomes bidirectional due to the presence of distributed generation plants. Electricity is shared among the several nodes of the

R. Morello, C. De Capua and G. Fulco are with the Department of Information Engineering, Infrastructure and Sustainable Energy (DIIES), University Mediterranea of Reggio Calabria, Italy (e-mail: rosario.morello@unirc.it decapua@unirc.it gaetano.fulco@unirc.it)

S.C. Mukhopadhyay is with the Department of Engineering, Macquarie University, NSW 2109, Australia (e-mail: Subhas.Mukhopadhyay@mq.edu.au)

power grid, named microgrids, based on local demand. So energy flow has to change dynamically even its direction. As a general rule, energy must be routed from microgrids with a large energy amount to microgrids having an energy lack. Nevertheless, several factors affect this general criterion such as the intermittent production of energy from renewable sources. In addition, the quality of the voltage and current signals provides further constraints to energy routing.

Consequently, the management of energy flow becomes today a really complex task, [1]. Currently, these aspects are not paid with sufficient attention in the grid. As a consequence, the final user sometimes has to tolerate energy having low quality. The major consequences are paid by the domestic users. Therefore today, uninterrupted energy supply and high quality energy are two basic and fundamental requirements to be guaranteed in the transmission and distribution of electricity.

This new concept entails new and important challenges for researchers dealing with this field. Several issues and problems must be faced such as the development of new efficient and smart sensing systems. Contextually, electric network needs a radical renovation to be able to change dynamically its configuration. In fact, the current architecture was projected to manage only mono-directional energy flow from the central generation plant to the final users.

Such a new scenario requires new systems which allow the power grid to be really smart by managing the bi-directional and changing flow of energy, [1]. In addition these systems must assure interoperability between new and old equipment. Figure 1 shows the current scenario, where different distributed generation plants supply their energy to users and provide the surplus to the electric network. However, energy production from renewable sources suffers from supply discontinuity. Thus, the risk of blackouts and service inefficiency increase. The smart power grid should be able to prevent promptly a supply discontinuity [2]. These features require the use of advanced and innovative sensing systems.

So sensors must make measurements and process results in real time to get a clear overview of power grid state in each node. For instance, power meters are sensing systems which are able to measure power features. Depending on its purpose, measures can include just power consumption or additional information concerning the power quality [3]-[5].



Fig. 1. The current scenario of the Power Grid [1].

The general architecture of a power meter consists of a voltage transducer, a current transducer, an A/D converter and a processor for processing data. At the present time, most of the commercial power meters perform measurement of active power. This parameter is commonly used for computing the user power consumption. Few power meters provide information on the power quality. Anyway, such information is not used by power grid for managing the energy delivery or billing the consumptions. In addition, in literature several definitions of reactive power exist, as a consequence the metrics or power computing algorithms are not worldwide univocally defined. Therefore the concept of metric is still object of studies and research activities.

In this paper, the authors propose their idea of the future smart power grid. In detail, power meters will be integrated in the electric grid to provide information concerning local energy consumption and the quality of power in the several nodes of the electric network. Such augmented information, supported by new decision criteria, will allow the power grid to manage fault events or rapid changes in energy requirements. The electric grid can be compared with the internet network. Therefore Internet of Things (IoT) can provide new opportunities to developers during the project of smart power meters. IoT can provide new criteria for sharing data and information into the whole grid, [6], such as multi-hop communication, where each sensor communicates through several successive nodes. In this sight, IoT can allow sensors to share information by using internet and web service architectures so to improve the grid management, [7]. In addition, sensing systems must cooperate and satisfy several features such as to be flexible to changing conditions, be able to monitor and predict electrical energy consumption, and to control the grid security. So ISO/IEC/IEEE 21451 Standards can allow smart grid to improve its efficiency by making easy the interoperability among several sensing systems due to the protocol standardization. In such a scenario, the modernization of the electric network will be possible by means of power meters geographically distributed, which can cooperate to

monitor the grid by performing a distributed data processing, [8]-[14].

The project, development and experimental validation of a smart power meter able to monitor the power in real-time are described in the following Sections. The next Section describes the proposed smart power meter. Section III reports the validation and experimental results. Section IV provides a brief description of the application to the future power grid based on a IoT vision. The conclusions have been drawn in Section V.

II. THE SMART POWER METER

The above described future vision of smart grid needs the project and development of innovative sensing systems with specific features. The solution proposed in the present paper is based on a smart power meter with improved characteristics:

- remotely programmable and controllable;
- interoperability among several power meters;
- embedded data processing and decision making algorithms;
- power quality analysis;
- decision-based management of energy flow routing according to the power quality requirements defined by the final user.

The hardware architecture and the soft computing algorithms are described in the following sub-Sections. A remote control station has been developed in order to manage information coming from different power meters so to simulate a central management station for controlling and performing in real-time the configuration of the power network. A further sub-Section describes in brief the potentialities offered by ISO/IEC/IEEE 21451 Standards.

A. Hardware Architecture

The smart power meter architecture is based on a *National Instruments Single-Board RIO 9626*. Two transducers allow to acquire the voltage and current signals, which are successively

digitally converted for data processing. In detail, the power meter mounts on board two additional modules: NI-9225 and NI 9246. A 400 MHz processor with 512 MB non-volatile storage and 256 MB DRAM performs the real time data processing. The processor is supported by a reconfigurable Xilinx Spartan-6 LX45 FPGA for custom timing, inline processing, and control tasks, see Figure 2 for reference.

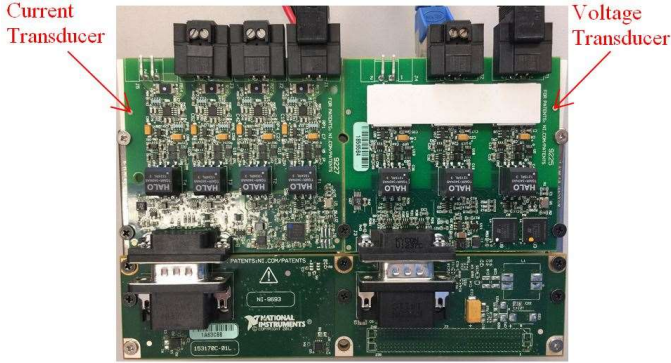

Fig. 2. The Smart Power Meter.

Table I reports the main electrical and technical specifications of the power meter.

TABLE I
SMART POWER METER SPECIFICATIONS

Quantity	Value
Voltage Range	0-300 Vrms
Current Range	0-20 Arms
Peak Current	30 A
Maximum Sampling Frequency	50 kS/s
Resolution	24 bit
Temperature Operating Range	-40 - +70 °C
Dimension	15.4x10.3x5 cm
Mass	350 g
Supply Voltage	9-30 V

The power meter is compliant with the specifications reported in the guidelines of IEC 61000-4 Standards family [15]-[17], and of IEC 62052-11 and IEC 62053-21 Standards [18], [19]. The technical specifications in Table I and the data processing algorithms allow the performed measurements to meet the specifications for the range of uncertainty defined for metering instruments of *class A* [17].

The meter performs in the following order these operations:

1. synchronous acquisition of voltage and current waveforms with a sampling rate of 5 kS/s;
2. FFT calculation of voltage and current waveforms (see Section II.B);
3. evaluation of several power and electrical parameters according to embedded metrics in compliance with the IEEE Std.1459-2010 [20] (see Section II.B);
4. characterization of power quality disturbance events.

The detected events are stored and can be used by the remote control station for managing and configuring the

power grid on needs (see Section II.C).

B. Metrics and Signal Processing Algorithms

The NI Single-Board RIO 9626 has been programmed by using the National Instruments LabVIEW software environment. It is a graphical programming language; the source code has been developed with the LabVIEW Real Time Tool. In this way, the projected smart power meter is a standalone system able to perform the previous four operations in real-time both on-line and off-line. The code section concerning the data processing has been entirely developed by using all metrics suggested in the IEEE Std.1459-2010, [21],[22]. Lastly, a Fast Fourier Transform (FFT) algorithm allows to evaluate the harmonic content of the voltage and current signals. All computed parameters are reported with more detail in Table II.

TABLE II
COMPUTED PARAMETERS

Parameter	Description	Measurement Unit
P_C	Active Power Consumption per hour	kW/h
Q_C	Reactive Power Consumption per hour	var/h
P_1	Fundamental Active Power	W
P_H	Harmonic Active Power	W
P	Total Active Power	W
Q_1	Fundamental Reactive Power	var
S	Apparent Power	VA
S_1	Fundamental Apparent Power	VA
S_H	Harmonic Apparent Power	VA
D_1	Current Distortion Power	var
D_V	Voltage Distortion Power	var
S_N	non-Fundamental Apparent Power	VA
N	non-Active Power	var
PF	Power Factor	-
HP	Harmonic Pollution	-
PF_1	Fundamental Power Factor	-
THD_V	Voltage Total Harmonic Distortion	-
THD_I	Current Total Harmonic Distortion	-
k	Crest Factor	-
f	Frequency	Hz
V_{rms}	root mean square Voltage	V
V_{pk}	peak Voltage	V
V_1	Fundamental Voltage	V
V_H	Harmonic Voltage	V
$V_{rms,i}$	root mean square Voltage of i-th harmonic with $2 < i < 40$	V
I_{rms}	root mean square Current	A
I_{pk}	peak Current	A
I_1	Fundamental Current	A
I_H	Harmonic Current	A
$I_{rms,i}$	root mean square Current of i-th harmonic with $2 < i < 40$	A

The previous parameters allow the meter to provide a complete overview about the energy flowing in a specific node of the electric grid. Figure 3 shows, as an example, a section of the developed code.

Data concerning voltage and current signals, frequency, power consumption and power quality is stored and made accessible to a remote control station for decision making purpose.

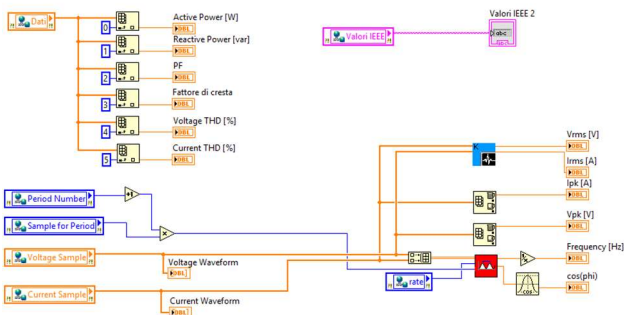

Fig. 3. A detail of the Source Code.

Each record includes date and time of the event, type of disturbance (sag, swell or interruption), maximum value over the threshold, duration of the event. In detail, the power meter compares the measurement results with user-defined thresholds in order to characterize specific stationary and transient events or supply discontinuities (voltage swell, voltage dip, overvoltage, undervoltage, voltage sags, micro-outages, voltage fluctuations, short and long breaks, impulsive overvoltage, over-current, blackouts, etc...) so to send a warning or an alert message to the remote control station if necessary.

In addition, the embedded metrics allow the smart meter to characterize the bi-directional power flow through the node. In detail, by considering the current sign, the meter is able to distinguish if the power is supplied by the node to the other ones (power production) or if it is consumed by the node (power consumption). Such information provides important evidence about the power flow in the grid from microgrids with a large energy amount to microgrids having an energy lack.

C. Remote Control Station

The power meter has been projected in order to permit the interoperability among several meters geographically distributed in the grid. For this reason, a software-based control panel has been developed to make possible the communication with each meter. The program runs on a server which could simulate the control center of a smart power grid.

By internet network or the same electric network, the control station can get access simultaneously to several meters of the grid acquiring the computed data. The control station can even reconfigure or reprogram the single meter if required. Figure 4 shows a screenshot of the control panel.

By means of the control panel, the remote control station gets a clear overview of the grid state in each node. Information concerning the voltage and current waveforms, power quality, stationary and transient events or supply discontinuities provide to the control center an instantaneous snapshot of the grid so to manage in real time the energy routing along specific and suitable paths. In this way, information collected by the smart meter is used to configure the grid, so to manage the power flow in a bi-directional way

from or toward a specific node depending on needs.

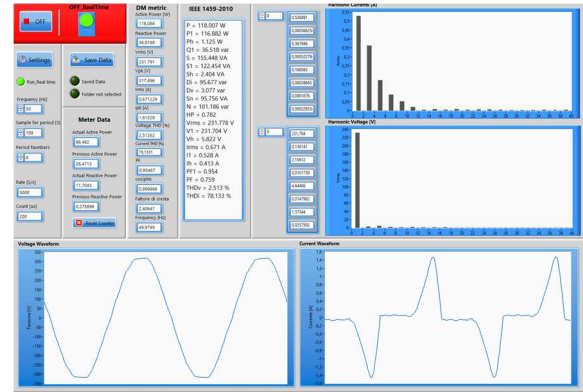

Fig. 4. Screenshot of the Remote Control Panel.

The Control Station is configured to communicate with each smart meter of the grid every hour to reduce the network congestion. It is the standard time interval used to evaluate the power consumption. However, depending on needs, this time interval can be decreased or increased. To guarantee the interoperability among the meters, embedded decision criteria allow each meter to characterize the occurrence of specific faults or inefficiency conditions of the power grid. In detail, the meter puts constantly in comparison the measurement results of each parameter in Table II with user-defined reference values. When a threshold is overcome, the meter alerts the Control Station. That can occur for example when quality standards go down fixed tolerable limits, or when a blackout occurs, or when power consumption of the node overcomes the power supply. Successively, the meters in the neighbouring nodes are demanded to synchronize their measurements. Results are sent to the Remote Control Station for processing data. Information on power consumption and power quality allows the grid control center to manage efficiently the energy routing by acting on actuators located in the nodes so to configure the electric network according to needs. For an instance, microgrids which supply energy with poor quality can be isolate, or nodes with a large power amount are connected with nodes having a power lack. All that can happen dynamically when network faults, malfunctions or disruptions occur.

To improve the interoperability features, the projected smart meter is even able to communicate directly with the other neighbouring meters so to demand power measurements or to synchronize them. These features can be configured according to the power grid requirements. Since the specific application case refers to a small-sized power grid, the control and communication rights have been exclusively assigned to the Remote Control Station. So the single smart meter is configured to communicate only with the control center. However, when the power grid size increases, it could be preferable to transfer specific communication and control rights to peripheral meters so to decongest the network and to decentralize the grid management task.

D. ISO/IEC/IEEE 21451-x Standards

The projected power meter is compliant with the guidelines of the IEEE 21451 Standards family so to provide a network-independent communication interface. This aspect becomes basic when we consider that several smart transducers and sensors will be dislocated along the power grid. Therefore, to guarantee the interoperability among the several sensing systems, the project and development of any device need standardization. The growing demand and interest in smart sensing systems has induced Working Groups of experts to revise the family of ISO/IEC/IEEE 21451-x Standards with the joint effort of ISO/IEC/JTC1. The aim of ISO/IEC/IEEE 21451-x Standards family is to provide a guideline for projecting smart transducer interfaces and smart sensor networks, [23]-[27]. The Standards allow users and designers to project smart sensing systems by using different protocols, such as eXtensible Messaging and Presence Protocol (XMPP), TCP/IP, HTTP, and Web services so to make easy communication among sensors and/or actuators distributed in a wide sensing network. Transducer Electronic Data Sheets (TEDS) are used for sensor identification and configuration purpose. Additional Standards of ISO/IEC/IEEE 21451-x family deal with the signal treatment. In such a scenario, the project of sensing systems for smart grid needs specific attention. For this reason, the remote control panel in the Section II.C has been developed to implement a *Network Capable Application Processor* (NCAP). The NCAP performs the following functions:

- *Transducer Interface Module (TIM) Discovery;*
- *Transducer Electronic Data Sheet (TEDS) Reading;*
- *Transducer Data Reading.*

The *TIM Discovery* function allows individuating the available TIMs and automatically adding them to the list of the installed power meters [28]. In this way, it is possible to expand the meter network according to needs. In the TEDS of each smart power meter are stored data concerning its identification, its geographical location, technical specifications, last calibration, next calibration interval.

III. VALIDATION AND EXPERIMENTAL RESULTS

In this Section, the tests performed to validate the above described smart power meter are reported. Two test bench configurations have been developed to execute three different test sets. In detail, a preliminary test set has allowed us to validate the measurement results provided by the voltage and current transducers (hardware testing, see Section III.A). A second test set has been performed to check the FFT algorithm so to evaluate the meter capacity to discriminate the several harmonic contributions of the voltage and current signals (software testing, see Section III.B). And then finally, a further experimentation has been performed on a real application case to check the precision of the embedded metrics and the measurement accuracy of the power meter (experimental

validation, see Section III.C).

A. Voltage and current transducers testing

To check the accuracy of the two transducers, the test bench configuration in Figure 5 has been used. In detail, a *Calibrator FLUKE 5500A* has been configured to test the calibration curve of each transducer. The environment temperature has been controlled and kept constant to 25 °C for the whole test. Several sinusoidal voltage and current waveforms have been generated with a frequency of 50 Hz and with steps of 10 V and 1 A of rms amplitude, respectively, in compliance with the respective measurement ranges, see Table I.

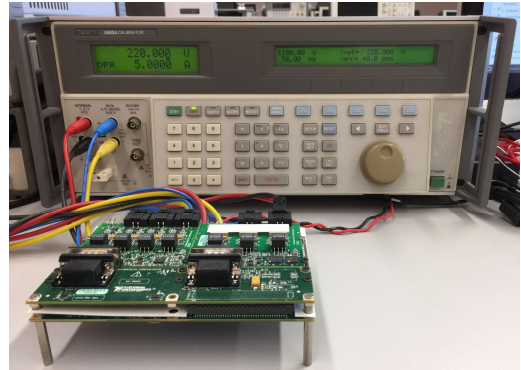

Fig. 5. Overview of the first test bench configuration.

Results are reported in Tables III and IV.

TABLE III
VOLTAGE TRANSDUCER CALIBRATION CURVE (50 Hz)

Reference Value [V]	Measured Value [V]	Percentage Deviation %
10	9.9978	0.0220
20	19.9957	0.0215
30	29.9942	0.0193
40	39.9856	0.0360
50	49.9895	0.0210
60	59.9842	0.0263
70	69.9826	0.0248
80	79.9865	0.0168
90	89.9810	0.0211
100	99.9811	0.0189
110	109.976	0.0218
120	119.976	0.0200
130	129.974	0.0200
140	139.980	0.0142
150	149.971	0.0193
160	159.970	0.0187
170	169.981	0.0111
180	179.973	0.0150
190	189.963	0.0194
200	199.973	0.0135
210	209.973	0.0128
220	219.966	0.0154
230	229.969	0.0134
240	239.964	0.0150
250	249.963	0.0148
260	259.957	0.0165

270	269.963	0.0137
280	279.955	0.0160
290	289.989	0.0037
300	299.955	0.0150

TABLE IV
CURRENT TRANSDUCER CALIBRATION CURVE (50 Hz)

Reference Value [A]	Measured Value [A]	Percentage Deviation %
1	1.0001	0.0100
2	2.0002	0.0100
3	2.9992	0.0266
4	3.9988	0.0300
5	4.9984	0.0320
6	5.9983	0.0283
7	6.9982	0.0257
8	7.9962	0.0475
9	8.9943	0.0633
10	9.9970	0.0300
11	10.9939	0.0554

The results show a maximum percentage deviation equal to 0.036% for the voltage calibration curve and 0.0633% for the current calibration curve. The estimated voltage and current offset values are 0.001 V and 0.0014 A, respectively. Such results are compliant with the IEC requirements concerning the electricity metering equipment so confirming the *class A* for the projected power meter [17]-[19].

B. FFT and Harmonics Detection testing

The test bench in Figure 5 has been furthermore used to check the accuracy of the harmonics detection performed by the FFT algorithm. The Calibrator has been programmed to generate six sinusoidal voltage and current waveforms with different frequency values. For each waveform, the voltage amplitude has been set equal to 230 V_{rms} with a current amplitude of 5 A_{rms}. The harmonics until the seventh order have been considered for this test, since they are the harmonics which occur frequently in the real case. The results are showed in Tables V and VI for the voltage and current waveforms, respectively. The maximum percentage deviation obtained for the voltage waveform is equal to 0.0282% and equal to 0.096% for the current waveform. The values show a good accuracy of the harmonics detection algorithm to discern the harmonic content for each waveform.

TABLE V
FFT ALGORITHM TESTING (VOLTAGE WAVEFORM)

Harmonic Order	Frequency [Hz]	Reference Value [V]	Measured Value [V]	Percentage Deviation %
2	100	230	229.945	0.0239
3	150	230	229.959	0.0178
4	200	230	229.956	0.0191
5	250	230	229.951	0.0213
6	300	230	229.951	0.0213
7	350	230	229.950	0.0217
8	400	230	229.944	0.0243

9	450	230	229.946	0.0234
10	500	230	229.935	0.0282

TABLE VI
FFT ALGORITHM TESTING (CURRENT WAVEFORM)

Harmonic Order	Frequency [Hz]	Reference Value [A]	Measured Value [A]	Percentage Deviation %
2	100	5	4.9985	0.030
3	150	5	4.9983	0.034
4	200	5	4.9952	0.096
5	250	5	4.9986	0.028
6	300	5	4.9985	0.030
7	350	5	4.9986	0.028
8	400	5	4.9982	0.036
9	450	5	4.9981	0.038
10	500	5	4.9979	0.042

C. Experimental Results

An additional experimental analysis has been performed by considering a specific application case. The used test bench configuration is showed in Figure 6.

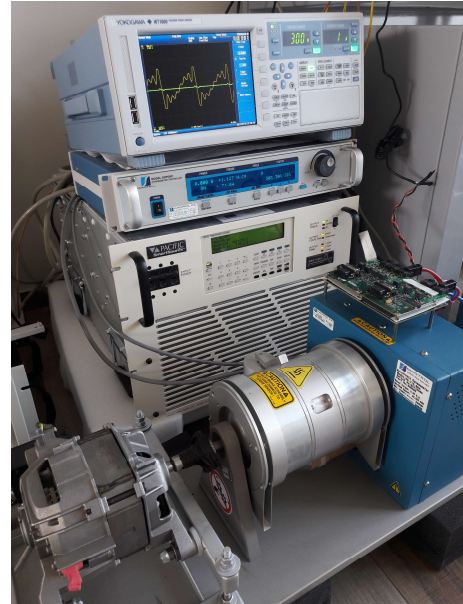

Fig. 6. Overview of the second test bench configuration.

The test equipment consists of an *AC Power Source Pacific 360-AMX* with programmable controller, a *Precision Power Analyzer Yokogawa WT1800*, an electric motor used as load, a *Hysteresis Dynamometer Magtrol HD-715-8NA* with a *Dynamometer Controller Magtrol DSP6001*.

The load has been supplied by applying a sinusoidal voltage of 225 V_{rms} amplitude and a frequency of 50 Hz generated by the power source. Voltage harmonic components until the seventh order have been added to the voltage signal in order to simulate non-sinusoidal operating conditions. Each harmonic has been generated with an amplitude equal to 30% of fundamental component amplitude. The voltage and current

waveforms are shown in the Figures 7 and 8, respectively.

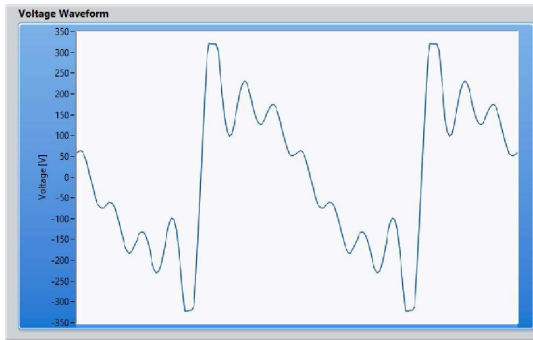

Fig. 7. Voltage waveform.



Fig. 8. Current Waveform.

The harmonic components of the voltage and current waveforms are depicted in Figure 9.

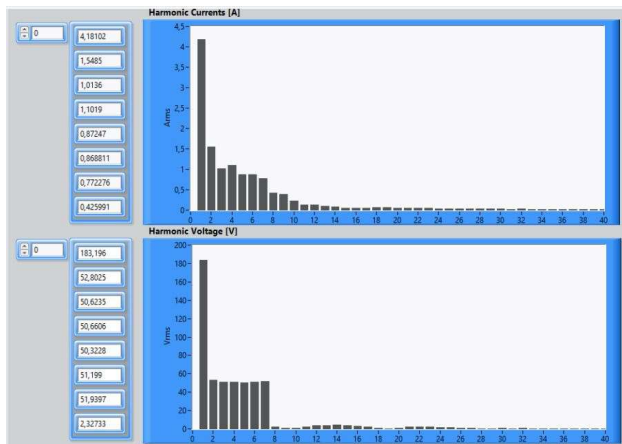

Fig. 9. Harmonics components of the voltage and current signals.

By analysing the previous figure, it is possible to observe the presence of harmonic components beyond the seventh order. That is the result of the distortion introduced by the load. The control panel displayed by the remote control station is reported in Figure 10. The panel shows all parameters measured by the smart power meter as reported in Table II. Each measured value has been put in comparison with the value provided by the power analyser, which has been considered as a reference for this experimentation.

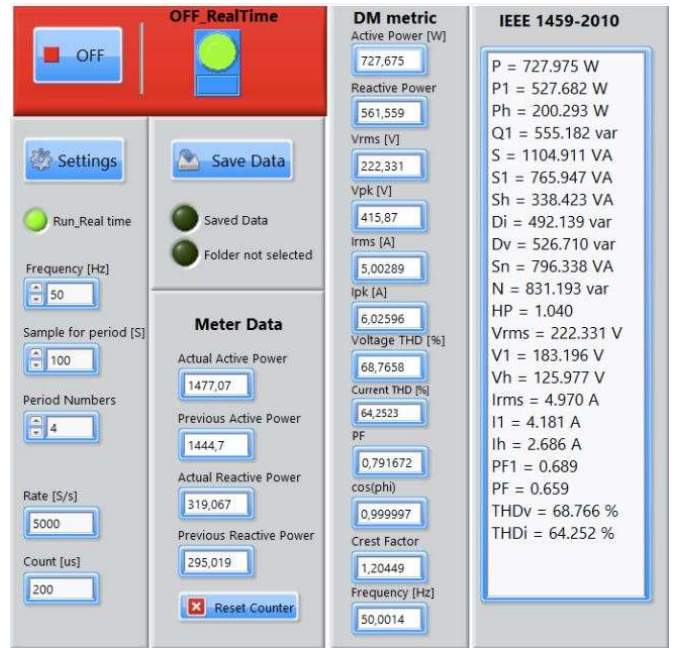

Fig. 10. Control Panel of the Remote Control Station.

Table VII reports the results of the experimental comparison.

TABLE VII
EXPERIMENTAL VALIDATION RESULTS OF THE SMART POWER METER

Parameter	Reference Value	Measured Value	Percentage Deviation %
P_C [kW/h]	-	n.a.	-
Q_C [var/h]	-	n.a.	-
P_1 [W]	530.600	527.682	0.5499
P_H [W]	214.800	200.293	6.7537
P [W]	745.400	727.975	2.3376
Q_1 [var]	860.600*	555.182*	35.4889*
S [VA]	1139.700	1104.911	3.0524
S_1 [VA]	778.4200	765.947	1.6023
S_H [VA]	347.8185	338.423	2.7012
D_I [var]	507.8204	492.139	3.0879
D_V [var]	533.1599	526.710	1.2097
S_N [VA]	832.4532	796.338	4.3384
N [var]	860.600	831.193	3.4170
PF	0.6556	0.659	0.5186
HP	1.06	1.040	1.8867
PF_1	0.6816	0.6890	1.0856
THD_V	56.661 %	68.766 %	21.3639
THD_I	56.456 %	64.252 %	13.8089
k	-	1.2045	-
f [Hz]	50.0020	50.0014	0.0011
V_{rms} [V]	223.0200	222.331	0.3089
V_{pk} [V]	417.6800	415.8700	0.4333
V_1 [V]	183.7200	183.1960	0.2852
V_H [V]	125.8343	125.9770	0.1134
$V_{rms,i}$ [V]	1) 183.72	1) 183.1960	1) 0.2852
with $1 < i < 8$	2) 52.78	2) 52.8025	2) 0.0426
	3) 50.77	3) 50.6235	3) 0.2885
	4) 50.78	4) 50.6606	4) 0.2351
	5) 50.42	5) 50.3228	5) 0.1927
	6) 51.36	6) 51.1990	6) 0.3134

	7) 52.08	7) 51.9397	7) 0.2693
	8) 2.34	8) 2.32733	8) 0.5414
I_{rms} [A]	5.110	4.970	2.7397
I_{pk} [A]	6.235	6.025	3.3680
I_1 [A]	4.237	4.1810	1.3216
I_H [A]	2.7641	2.686	2.8255
$I_{rms,i}$ [A]	1) 4.237	1) 4.1810	1) 1.3216
with $1 < i < 8$	2) 1.615	2) 1.5485	2) 4.1176
	3) 1.078	3) 1.0136	3) 5.9740
	4) 1.176	4) 1.1019	4) 6.3010
	5) 0.943	5) 0.8724	5) 7.4867
	6) 0.941	6) 0.8688	6) 7.6726
	7) 0.844	7) 0.7722	7) 8.5071
	8) 0.495	8) 0.4260	8) 13.9393

- value not reported

* value obtained by using a different parameter definition

The analysis of the results does not allow us to make a complete comparison between the two measurement systems, since the projected smart power meter integrates a major number of metrics. In addition the two measurement systems use a different definition of the reactive power, as a consequence the parameter Q_I is not comparable. Anyway, by considering the only parameters in common, a significant percentage deviation has been obtained for the *Harmonic Active Power* parameter. It is due to an expected systematic error caused by the voltamperometric connection of the two instruments. This is cause of error on the measurement of the harmonic current components. It is useful to observe that the results of the FFT algorithm testing reported in the Section III.B have shown a maximum percentage deviation equal to 0.096%. This test has been performed by using a different test bench configuration, which has avoided the above described error. Consequently, the percentage deviations of the harmonic currents in Table VII are attributable to the voltamperometric method error.

IV. TOWARDS THE GRID OF THE FUTURE: THE IOT VISION

It is expected that the electric grid of future will be a complex flow of energy and information shared among several nodes. New sensing systems and services will be necessary to manage a so complex distributed system, [29]. Even protocols and standards will have an important role. The power grid can be compared to the internet network. Each node of the grid can be equipped with a power meter. The resulting sensing grid can be considered as a complex system geographically distributed. The power meter network will have the task to monitor in real time the energy flow of a large number of nodes. Such amount of information is used to make timely decisions when critical events occur. By gaining experience with the evolution of the internet network in the last years, such described scenario offers a large number of research topics. The internet protocol is universal and has been widely validated in the years. As a consequence, the real time control of the power grid could take advantage of internet so to use power meter data for taking timely decisions and configuring itself based on needs. Internet of Things (IoT) concept can

help to share information and data in the grid so to improve efficiency, reliability and security of the electric system [6]. IoT aims to add value by connecting objects to internet network. So IoT implies that power meters can be able to utilize internet to communicate data about their condition, position, or other measurement parameters. Therefore smart power meters will take advantage of this by using the internet network so making available data and information on the power grid with a new approach in respect to the past. Power meters can even monitor constantly the power line temperature so to estimate the carrying capacity of the line. Such information can be used to manage dynamically the power flow amount by using suitable *dynamic line rating* algorithms. Therefore, IoT can allow the smart power grid to increase its features and services. In this new scenario, IoT promises to turn a power meter into an object which provides information about the grid and its environment. This will create in the next future a new way to differentiate the services of the electric network and a new source of value. This IoT vision will improve the efficiency of the power grid and will provide new opportunities. The user will be able to define and change his/her power requirements, and the smart power grid will configure itself to assure the required power quality specifications.

The main issue to be faced in the next future concerns the large number of power meters and sensors to be managed and maintained. Typically, an electric grid consists of 10,000 or even 100,000 nodes. Consequently, the *scalability* issue should be resolved before considering a power grid to be smart. The *collaborative signal processing* among nodes is another important aspect. Even the querying ability is relevant to the electric grid of the future. A node or a power meter must be able to query an individual node or group of nodes for getting information concerning a specific microgrid. All these aspects have been formerly faced by the internet network. So the main features and characteristics today requested to the power grid are the same ones owned by the present internet network. Therefore, by a IoT vision, the power grid will be able to perform its tasks: demand management, disturbances detection, energy flow amount management, isolation of specific microgrids, management of the energy storage, transport of energy from any node it is produced to nodes where it is lacking by using innovative routing algorithms. In the view of the future power grid, smart power meters could resolve all the current difficulties concerning the sensing and measurement issues.

The projected smart power meter takes advantage of IoT concept. In fact, the current power meters are able to share information only with the control centre of the electric company just to bill the user power consumption. With a different approach, the proposed power meter shares information on consumption and power quality with the internet network to improve the management of the power grid. The power meter cannot be anymore considered as a simple instrument billing consumption. By such a IoT vision,

information on each node of the grid is shared with the whole grid to increase its efficiency. Measurement data is used to bill consumption but at the same time to configure the power network based on power demands and on the power quality requirements defined by the user. In this view, the described power meter implements the IoT concept to improve the features and the services offered by the future power grid.

However, several further issues remain still unsolved. In detail, the new challenges include:

- the standardization of communication protocols;
- the improvement of the security standards;
- integration of the sensing systems into existing systems to assure interoperability;
- harmonisation of equipment standards to allow plug-and-play and interface;
- new power flow routing algorithms and innovative routing criteria;
- management of big data coming from thousands of sensing systems distributed through the grid;
- redefinition of the metrics used for billing consumptions;
- modernisation of current electric network architecture.

V. CONCLUSIONS

The paper proposes an innovative smart power meter to monitor the energy flow in smart power grids. Expecting the power grid of the future, the authors take stock of the situation concerning the state of the current power grid. Weaknesses and strengths are discussed so to highlight the role of the advanced sensing systems in the power grid management. Other issues remain still unsolved before that the power grid can be considered really smart. IoT offers new interesting answers in order to face and resolve such issues. So this paper intends to solicit the debate on the role of IoT in the development of the power grid of the next future. The current power network needs to be updated in order to adapt itself to the new requirements of the current power demand. As a consequence, there is still much to be done especially in the matter of defining the most suitable architecture of the electric network. By means of the proposed IoT vision, the projected smart power meter uses the internet network to improve the efficiency and features of the power grid.

The paper aims to propose a possible solution to the issues concerning the sensing and measurement aspects by discussing the potentialities of the developed smart power meter. The project and development of the proposed power meter have been described in the paper. Hardware architecture and software algorithms have been outlined. In detail, the embedded metrics offer additional information on the energy flowing in the grid nodes in respect to the other commercial power meters. The main strengths concern:

- the possibility to control and program remotely the

meter;

- data are processed in real time to support the decision making tasks;
- the remote control station is able to manage simultaneously several smart meters;
- the embedded metrics offer new potential criteria to manage efficiently the energy routing and sharing among several nodes by considering even the power quality features.

Tests and experimentation on an application case have allowed to validate the developed prototype. Two test benches have been used for testing the hardware and software operations. The additional experimental results have proved the compliance of the power meter with the IEC requirements.

REFERENCES

- [1] Smart Grids, European Technology Platform, Vision and Strategy of Europe's Electricity Networks of the Future, European Commission Document EUR 22040, Directorate-General for Research, 2006.
- [2] IEEE Smart Cities, Accessed on 10th July, 2017. [Online]. Available: <http://smartgrid.ieee.org/>.
- [3] L. Morales-Velazquez, R. de Jesus Romero-Troncoso, G. Herrera-Ruiz, D. Morinigo-Sotelo, R. Alfredo Osornio-Rios, "Smart sensor network for power quality monitoring in electrical installations", *Measurement*, Vol. 103, pp. 133-142, 2017.
- [4] A. Cataliotti, V. Cosentino, D. Di Cara and G. Tinè, "LV Measurement Device Placement for Load Flow Analysis in MV Smart Grids", in *IEEE Transactions on Instrumentation and Measurement*, Vol. 65, no. 5, pp. 999-1006, May 2016.
- [5] M. M. Albu, M. Sânduleac and C. Stănescu, "Syncretic Use of Smart Meters for Power Quality Monitoring in Emerging Networks", in *IEEE Transactions on Smart Grid*, Vol. 8, no. 1, pp. 485-492, Jan. 2017.
- [6] <http://iot.ieee.org/>
- [7] S. Uludag, K. S. Lui, W. Ren and K. Nahrstedt, "Secure and Scalable Data Collection with Time Minimization in the Smart Grid", in *IEEE Transactions on Smart Grid*, vol. 7, no. 1, pp. 43-54, January 2016.
- [8] B. Kul, "IP-based smart sensors for energy metering and efficient HVAC infrastructure in buildings", 2017 15th International Conference on Electrical Machines, Drives and Power Systems (ELMA), Sofia, Bulgaria, pp. 258-261, 2017.
- [9] M. Burunkaya, T. Pars, "A smart meter design and implementation using ZigBee based Wireless Sensor Network in Smart Grid", 2017 4th International Conference on Electrical and Electronic Engineering (ICEEE), Ankara, pp. 158-162, 2017.
- [10] Y. Kabalci, "A survey on smart metering and smart grid communication", *Renewable and Sustainable Energy Reviews*, Vol. 57, pp. 302-318, May 2016.
- [11] L. I. Minchala-Avila, J. Armijos, D. Pesántez, Y. Zhang, "Design and Implementation of a Smart Meter with Demand Response Capabilities", *Energy Procedia*, Vol. 103, pp. 195-200, December 2016.
- [12] K. Sharma, L. M. Saini, "Performance analysis of smart metering for smart grid: An overview", *Renewable and Sustainable Energy Reviews*, Vol. 49, pp. 720-735, September 2015.
- [13] D. Ramírez Muñoz, D. Moro Pérez, J. Sánchez Moreno, S. Casans Berga, E. Castro Montero, "Design and experimental verification of a smart sensor to measure the energy and power consumption in a one-phase AC line", *Measurement*, Vol. 42, Issue 3, pp. 412-419, 2009.
- [14] N. K. Suryadevara, S. C. Mukhopadhyay, S. Dieter, T. Kelly, S. P. S. Gill, "WSN-Based Smart Sensors and Actuator for Power Management in Intelligent Buildings", in *IEEE/ASME Transactions on Mechatronics*, vol. 20, no. 2, pp. 564-571, April 2015.
- [15] IEC 61000-4-7 International Standard, "Electromagnetic compatibility (EMC) – Part 4-7: Testing and measurement techniques – General guide on harmonics and interharmonics measurements and instrumentation, for

power supply systems and equipment connected thereto”, 8 August 2002.

- [16] IEC 61000-4-15 International Standard, “Electromagnetic compatibility (EMC) – Part 4: Testing and measurement techniques – Section 15: Flickermeter – Functional and design specifications”, 24 August 2010.
- [17] IEC 61000-4-30 International Standard, “Electromagnetic compatibility (EMC) – Part 4-30: Testing and measurement techniques – Power quality measurement methods”, 20 February 2015.
- [18] IEC 62052-11 International Standard, “Electricity metering equipment (ac) – General requirements, tests and test conditions – Part 11: Metering equipment”, 12 February 2003.
- [19] IEC 62053-21 International Standard, “Electricity metering equipment (ac) – Particular requirements – Part 21: Static meters for active energy (classes 1 and 2)”, 28 January 2003.
- [20] IEEE 1459-2010: Definitions for the Measurement of Electric Power Quantities Under Sinusoidal, Nonsinusoidal, Balanced, or Unbalanced Conditions, 19 March 2010.
- [21] A. Kumar, I.P. Singh, S.K. Sud, “Energy Efficient and Low-Cost Indoor Environment Monitoring System Based on the IEEE 1451 Standard”, IEEE Sensors Journal, Vol.11, Issue 10, pp.2598-2610, 2011.
- [22] J. Guevara, A. Fatecha, E. Vargas, F. Barrero, “A reconfigurable WSN node based on ISO/IEC/IEEE 21451 standard”, Proc. of IEEE International Instrumentation and Measurement Technology Conference (I²MTC), pp.873-877, 2014.
- [23] ISO/IEC/IEEE 21450: Information technology — Smart transducer interface for sensors and actuators — Common functions, communication protocols, and Transducer Electronic Data Sheet (TEDS) formats, 2010.
- [24] ISO/IEC/IEEE 21451-1: Information technology -- Smart transducer interface for sensors and actuators - Part 1: Network Capable Application Processor (NCAP) information model, 2010.
- [25] ISO/IEC/IEEE 21451-2: Information technology -- Smart transducer interface for sensors and actuators - Part 2: Transducer to microprocessor communication protocols and Transducer Electronic Data Sheet (TEDS) formats, 2010.
- [26] ISO/IEC/IEEE 21451-4: Information technology — Smart transducer interface for sensors and actuators — Part 4: Mixed-mode communication protocols and Transducer Electronic Data Sheet (TEDS) formats, 2010.
- [27] ISO/IEC/IEEE 21451-7: Information technology — Smart transducer interface for sensors and actuators — Part 7: Transducer to radio frequency identification (RFID) systems communication protocols and Transducer Electronic Data Sheet (TEDS) formats, 2011.
- [28] R. Morello, C. De Capua, G. Lipari, M. Lugarà, G. Morabito, “A Smart Energy Meter for Power Grids”, 2014 IEEE International Instrumentation and Measurement Technology Conference (I²MTC 2014), May 12-15 2014, Montevideo, Uruguay, pp. 878-883, 2014.
- [29] L. Ferrigno, R. Morello, V. Paciello, A. Pietrosanto, “Remote metering in public networks”, Metrology and Measurement Systems, Vol. 20, Issue 4, pp. 705–714, October 2013.



Rosario Morello (M'03) was born in Reggio Calabria, Italy, in 1978. He received the M.Sc. Degree (cum laude) in Electronic Engineering and the Ph.D. Degree in Electrical and Automation Engineering from the University “Mediterranea” of Reggio Calabria, Italy, in 2002 and 2006, respectively. Since 2005, he has been Postdoctoral Researcher of Electrical and Electronic Measurements at the Department of Information Engineering, Infrastructure and Sustainable Energy of

the same University. At the present he is an Assistant Professor. His main research interests include the design and characterization of distributed and intelligent measurement systems, wireless sensor network, environmental monitoring, decision-making problems and measurement uncertainty, process quality assurance, instrumentation reliability and calibration, energy, smart grids, battery testing, biomedical applications and statistical signal processing, non-invasive systems, biotechnologies and measurement, instrumentation and methodologies related to Healthcare. Dr. Morello is a member of the Italian Group of Electrical, Electronic Measurements (GMEE) and IEEE.



Claudio De Capua (M'99) received the M.S. and the Ph.D. degrees in Electrical Engineering from the University of Naples “Federico II”, Naples, Italy. Since 2012, he is Full Professor of Electrical and Electronic Measurements at the Department of Information Engineering, Infrastructure and Sustainable Energy, University “Mediterranea” of Reggio Calabria. His current research includes the design, realization and metrological performance improvement of the automatic measurement systems; web sensors and sensor data fusion; biomedical instrumentation; techniques for remote didactic laboratory; measurement uncertainty analysis; problems of electromagnetic compatibility in measurements.

Prof. De Capua is member of the Italian Group of Electrical and Electronic Measurements (GMEE).



Gaetano Fulco was born in Reggio Calabria, Italy, in 1990. He received from the University “Mediterranea” of Reggio Calabria, Italy, a bachelor's degree in Electronic Engineering, in 2013, and the M.Sc. Degree (cum laude) in Electronic Engineering, in 2015. At the present he is Ph.D. Student of Information Engineering Course at the University “Mediterranea” of Reggio Calabria, Italy. His main research interests are development, realization and test of smart meter, power

quality, energy, smart grids.



Subhas Mukhopadhyay (M'97, SM'02, F'11) holds a B.E.E. (gold medalist), M.E.E., **Ph.D.** (India) and **Doctor of Engineering** (Japan). He has over 26 years of teaching, industrial and research experience.

Currently he is working as a Professor of Mechanical/Electronics Engineering, Macquarie University, Australia and is Discipline Leader of the Mechatronics Engineering Degree Programme. Before joining Macquarie he worked as Professor of Sensing Technology, Massey University, New Zealand. His

fields of interest include Smart Sensors and sensing technology, instrumentation techniques, wireless sensors and network, numerical field calculation, electromagnetics etc. He has supervised over 40 postgraduate students and over 100 Honours students. He has examined over 50 postgraduate theses.

He has published over **400** papers in different international journals and conference proceedings, written six books and thirty book chapters and edited **fifteen** conference proceedings. He has also edited **twenty-eight** books with Springer-Verlag and **seventeen** journal special issues. He has organized over 20 international conferences as either General Chairs/co-chairs or Technical Programme Chair. He has delivered **298** presentations including keynote, invited, tutorial and special lectures.

He is a **Fellow** of IET (UK), a **Fellow** of IETE (India), a **Topical Editor** of IEEE Sensors journal, and an **associate editor** of IEEE Transactions on Instrumentation and Measurements. He is a **Distinguished Lecturer** of the IEEE Sensors Council from 2017 to 2019. He **chairs** the IEEE IMS Technical Committee 18 on Environmental Measurements.

More details can be available at

<http://web.science.mq.edu.au/directory/listing/person.htm?id=smukhopa>