

First nucleotide sequence of a *Carlavirus* virus genus infecting caper

ANTONIO TIBERINI¹, TIZIANA MASCIA² and LAURA TOMASSOLI¹

¹Centro di Ricerca di Patologia Vegetale, Via C.G. Bertero 22, 00156 Roma, Italy

²Dipartimento di Biologia e Patologia Vegetale, Università di Bari e Istituto di Virologia Vegetale CNR, Via Amendola 165/A 70126 Bari, Italy

Summary. A carlavirus from asymptomatic caper plants (*Capparis spinosa* L.), that was provisionally considered a distinct isolate of the previously described *Caper latent virus*, was partially sequenced. The translated amino acid sequences of the RNA dependent RNA polymerase (RdRp) gene and coat protein (CP) gene were compared with the equivalent sequences of members of the genus *Carlavirus*. The isolate, named CapLV-L7, showed less than 78% and 72% amino acid identity in RdRp and CP regions, respectively, with the other carlaviruses tested. The closest sequence similarity was with *Nerine latent virus* and *Potato virus M*. The phylogenetic trees showed a close relationship of CapLV-L7 with *Nerine latent virus* in both genes.

Key words: sequence analysis, *Capparis spinosa*, virus infection.

Introduction

Caper (*Capparis spinosa* L.), a species originating in the Middle East, is cultivated throughout the Mediterranean Basin for the production of unopened flower buds: capers. These are used for human consumption as a spice and, to a lesser extent, for medicine and cosmetics (Sher and Alyemeni, 2010). In the Minor Sicilian Islands (Southern Italy), pests, fungi and viruses are becoming limiting problems for the caper production (Infantino *et al.*, 2007). In the past, three viruses have been reported infecting caper: a carlavirus always found in mixed infection with *Eggplant mottle dwarf virus* (EMDV) (Di Franco and Gallitelli, 1985) and *Cucumber mosaic virus* (CMV) (Tomassoli *et al.* 2005). In the first case, mature leaves of caper plants had symptoms of vein yellowing, which were shown to be induced by EMDV, while the carlavirus infection in caper was asymptomatic. For this reason the name of *Caper latent*

virus (CapLV) was given to the asymptomatic virus (Gallitelli and Di Franco, 1987). CapLV was assigned to the genus *Carlavirus* on the basis of: i) distant serological relationship to *Helenium virus S* (HVS), and ii) the morphology and composition of its particles. These were filamentous with a model length of 662 nm and were made up of a single species of protein subunit with a M_r of c. 37,500, which encapsidated a single stranded RNA with an apparent size of 9.100 nucleotides (Gallitelli and Di Franco, 1987). CapLV was sap-transmissible to a limited number of experimental hosts which included *Nicotiana benthamiana*, *N. clevelandii*, *N. glutinosa*, *N. megalosiphon*, *Petunia hybrida*, and locally to *Phaseolus vulgaris*, *Chenopodium quinoa* and *C. amaranticolor* (Gallitelli and Di Franco, 1987). The genus *Carlavirus*, family *Betaflexiviridae*, contains 43 described species (<http://www.ictvonline.org/virusTaxonomy.asp>). The carlavirus ssRNA (+) genome consists of six open-reading frames (ORFs), encoding helicase/replication related proteins (ORF1), three triple block proteins (ORF2, 3 and 4), a coat protein (CP) (ORF5) and a putative nucleic acid-binding regulatory protein (ORF 6) (Adams *et al.*, 2004).

Corresponding author: L. Tomassoli
Fax: +39 06 82070246
E-mail: laura.tomassoli@entecra.it

In particular, the ORF1 is widely used in phylogenetic studies, and it could be considered as an anchor because the replicase of carlaviruses is a papain-like proteinase with sequence similarity to replicases of the genera *Potexvirus*, *Furovirus*, *Capillovirus*, and *Tymovirus* (Martelli *et al.* 2007). Coat protein subunits are of one type and of 31–36 kDa in size. Most carlavirus species are transmitted by aphids in the non-persistent manner, a few members are reported to be transmitted by seed and those carlaviruses that infect vegetatively-propagated hosts persist in the propagative material.

Unlike most of the carlaviruses for which partial or complete genome nucleotide sequences have been published, no molecular information has been reported for CapLV. For this reason, in a previous study aimed to investigate on caper viruses (Tomassoli *et al.*, 2006), carlavirus group-specific primer mix (Agdia Inc. Elkhart, IN, USA) was used for CapLV identification. Several isolates were detected from symptomatic and asymptomatic caper plants by RT-PCR in the Minor Sicilian Islands, but attempts failed to serologically identify them with an antiserum against the Apulia isolate of CapLV described by Gallitelli and Di Franco (1987) and by mechanical inoculation on *Ch. quinoa* and *N. Benthamiana*.

Here we report a preliminary characterization of one of these caper carlavirus isolates by cloning and sequencing the genome regions corresponding to ORF1 and ORF5 regions and by comparing them with the corresponding sequences of other members of the genus *Carlavirus*.

Materials and methods

Among a large collection of Sicilian carlavirus isolates from caper, collected from either symptomless plants or symptomatic plants, one isolate from Linosa (Pelagie Islands - AG), the only island where neither EMDV nor CMV were found, was used to analyse the virus genome. The isolate was named CapLV-L7. Partial virus purification was achieved using the method described by Foster (1998) with minor modifications. Briefly, 50 g of infected leaf tissue of caper from Linosa were homogenized in two volumes (w/v) of 0.5 M borate buffer pH 7.8, containing 5mM EDTA and 0.1% thioglycolic acid. After clarification with an equal

volume of chloroform, virus particles were precipitated by polyethylene glycol (6000 wt), resuspended in 0.5 M borate buffer containing 1% Triton X-100 and concentrated by centrifugation at 30,000×g for 90 min. No further clarification was done and RNA was extracted from the partially purified suspension using the RNeasy Plant Mini Kit (Qiagen, Hilden, Germany) and quantified (400 ng μL^{-1}) by NanoDrop ND-1000 spectrophotometer (BioRad Laboratories GmbH, Munich, Germany).

Amplified products were synthesized from total RNA extracts using degenerate carlavirus primers based on conservative regions of carlaviruses and/or sequence specific primer sets derived from C-terminus ORF1 and ORF5 regions of CapLV-L7 (Table 1). Two microliters of total RNA were submitted to one step-one tube RT-PCR in a 25 μL volume containing 2.5 μL 10×buffer (Promega, Madison, WI, USA), 1.5 mM MgCl_2 , 2.5 mM of each dNTP, 0.5 mM of each primer, 20 U of RNase-OUT (Invitrogen, Carlsbad, CA, USA) 1.25 U of AMV RT (Promega), and 0.75 U of Taq polymerase (Promega). Reverse transcription was performed at 42°C for 60 min, followed by denaturation at 95°C for 5 min and by amplification reactions for 35 cycles at a denaturation temperature of 94°C for 1 min, an annealing temperature of 60°C for 1 min and an extension time at 72°C for 2 min. Half-time conditions and an annealing temperature of 58°C were applied with primers used for CP amplification. Reactions were terminated by an additional extension cycle of 72°C for 10 min. Amplified fragments were resolved by 1.5% agarose gel electrophoresis and visualized by ethidium bromide staining. RT-PCR products were cleaned by Microcon 100 Kit (Amicon, Inc., Beverly, MA, USA) and ligated into the pCRII vector in *E. coli* one-Shot chemically competent cells (TA cloning kit Dual Promoter, Invitrogen), according to manufacturer's instructions. Recombinant plasmids were extracted by Illustra Plasmid Minikit (GE Healthcare UK Ltd, Buckinghamshire, UK) and sequenced on both strands using T7 and SP6 universal primers (BioFab Research, Rome, Italy).

Multiple alignments were performed using Clustal W algorithm, and phylogenetic relationships were inferred with the neighbour-joining (NJ) method using 10,000 bootstrap replicates, both implemented in the MEGA 4 program (Tamura *et al.*, 2007). The CapLV-L7 sequences were

Table 1. Sequences and genome positions of primers used for caper carlavirus amplification by RT-PCR.

Primer	Sequence	Genome Position
Cap-O1D3	5'-GGTGATCCCKTGGCTSAA-3'	ORF1 RdRp
Cap-H4206R	5'-CCATCGTGTTGAAGAGGAATGTACT-3'	ORF1 RdRp
Cap-O1D1	5'-GGCHCTHACWTACAGGAGTCC-3'	ORF1 RdRp
Cap-O1D2	5'-CTGGCYGAACAATTG-3'	ORF1 RdRp
Cap-O1R1	5'-GGCTCAAGMDAGGTKATGAA-3'	ORF1 RdRp
Cap-O2D1	5'-TGCCACTTACACCGCCGCT-3'	ORF2
Cap O5-CP61R	5'-GTAAGTAGATATTCCAATGTAATGGTGGT-3'	CP
CARLA O5-D1	5'-GAGATCGGNAGGCCT-3'	CP
CARLA CP	5'-GGBYTNGGBGTNCCNACNGA-3'	CP

compared to those of other carlaviruses using EMBOSS Pairwise Alignment Algorithms.

The following carlaviruses (respective GenBank accession numbers indicated) were used in sequence alignments, nucleotide and amino acid identity calculation and phylogenetic analysis: *Aconitum latent virus* (AcLV): NC002795; *Blueberry scorch virus* (BISV): NC003499; *Carnation latent virus* (CLV): X52627; *Cowpea mild mottle virus* (CpMMV): NC014730; *Coleus vein necrosis virus* (CVNV): NC009764; *Chrysanthemum virus B* (CVB): NC009087; *Daphne virus S* (DVS): NC008020; *Garlic common latent virus* (GCLV): GQ475423; *Helenium virus S* (HVS): D10454; *Hel-leborus net necrosis virus* (HeNNV): NC012038; *Hop latent virus* (HpLV): NC002552; *Hop mosaic virus* (HpMV): NC010538; *Kalanchoë latent virus* (KLV): NC013006; *Ligustrum necrotic ringspot virus* (LNRSV): EU074853; *Lily symptomless virus* (LSV): AJ516059; *Melon yellowing-associated virus* (MYaV): AY373028; *Narcissus common latent virus* (NCLV): NC008266; *Nerine latent virus* (NeLV): NC011540; *Pas-siflora latent virus* (PLV): NC008292; *Pea streak virus* (PSV): AF354652; *Poplar mosaic virus* (PopMV): NC005343; *Potato latent virus* (PotLV):

EU433397; *Potato virus M* (PVM): HM854296; *Potato virus P* (PVP): EU338239; *Potato virus S* (PVS): NC007289; *Red clover vein mosaic virus* (RCVMV): NC012210; *Shallot latent virus* (SLV): NC003557; *Sweet potato chlorotic fleck virus* (SPCFV): NC006550; *Verbena latent virus* (VeLV): AF271218. *Apple stem grooving virus* (ASGV) as member of *Capillovirus* genus (*Betaflexiviridae* family) was used as an outgroup (HM352772).

Results and discussion

The nucleotide sequences ORF1 (1120 bp) and ORF5 (945 bp) regions of CapLV-L7 were determined and deposited in GenBank with the accession numbers HQ588147 and HQ588148, respectively. Database search revealed that the ORF1 and ORF5 sequences of CapLV-L7 had the closest similarity to the region corresponding to the C terminal region of ORF1, coding for the RNA dependent RNA polymerase (RdRp), and the complete coat protein (CP) of carlaviruses, respectively. The partial ORF1 sequence of CapLV-L7 displayed 63–73% amino acid identity with corresponding sequences of members of the genus *Carlavirus* (Table 2) showing the closest similarity with *Hip-*

Table 2. Percentage identities and similarities (refers to amino acid residues of the same group) of the RdRp and CP amino acids sequences between CapLV-L7 and other members of the genus *Carlavirus*.

Carlavirus ^a	RdRp region (1120 nt)		CP Region (945 nt)	
	Identity	Similarity	Identity	Similarity
AcLV	72.1	83.7	53.8	71
BISV	71.8	84	43.2	58.6
CLV	–	–	35.2	53.9
CpMMV	73.5	86.3	48.6	64.8
CVB	73	83.4	35.5	51.7
CVNV	64.9	76.4	35.1	53.4
DVS	74.4	85.2	47.8	61.7
GCLV	–	–	33.7	52.8
HeNNV	71.5	81.7	36.3	52.4
HpLV	71.5	84.9	52.1	69.5
HpMV	69.8	82.6	50.6	69.1
HVS	–	–	43.1	59.9
KLV	71.5	83.4	40.8	56.7
LNRSV	72.7	83.7	42.4	54.5
LSV	71.2	83.7	41.4	58.6
MYaV	–	–	28.3	46.1
NCLV	72.7	83.1	52.2	68.0
NeLV/HipLV	77.9	87.5	52.8	67.8
PLV	71.5	84.3	49.9	54.8
PopMV	74.1	83.7	33.3	50.1
PotLV	72.4	82	45.6	61.5
PSV	–	–	32.8	55.1
PVM	75.3	84.9	55.9	71.1
PVP	73	84.6	44.1	60.6
PVS	73	83.7	36.5	53.4
RCVMV	68.1	80.1	32.3	53.0
SLV	–	–	34.3	54.2
SPCFV	62.6	77.8	28.4	46.6
VeLV	70	82.4	–	–

^a See text for full virus names and GenBank accession numbers of their nucleotide sequences.

peastrum latent virus (HipLV), recently found to be NeLV (Table 2). The amino acid sequence of the partial CapLV-L7 ORF1 shares 78% identity with the corresponding region of NeLV and contains the eight catalytic conserved motifs (POL I–VIII) of supergroup 3 (Prosite search), previously identified in members of the genus *Carlavirus* corresponding to RNA-dependent RNA polymerase

(RdRp) of positive ssRNA virus catalytic domain profile (Hataya *et al.*, 2000). The POL regions of CapLV-L7 showed 100% identity with a high number of carlaviruses so far sequenced, with the exception of POL V (P₂₄₃ and K₂₄₆ residues) and POLVIII that differed in the region within 319–323 residues. CapLV-L7 ORF5 nucleotide and amino acid sequences shared 46–57% and 28–

56% identity, respectively, with the coat proteins of the other carlaviruses. The closest similarities of the CP sequences were detected with AcLV, at nucleotide level, and with PVM at amino acid level (Table 2). CapLV-L7 encodes a putative CP with an estimated M_r of 34.8 kDa (314 aa). The CP core region (aa 164–267) was the most conserved sharing 78% identity with AcLV and 79% with PVM. Multiple alignment of the CapLV-L7 coat protein with the corresponding products of 29 carlaviruses showed the conserved amino acid

motif $A_{239}A_{240}F_{241}D_{242}$, in the core region, that is present in all filamentous plant viruses (Koonin and Dolja, 1993), and the $T_{296}G_{297}G_{298}XXG_{301}$ motif, in the C-terminal region, that is conserved in all carlaviruses (Hataya *et al.*, 2000).

On RdRp domain, as well as the one based on the CP gene, phylogenetic analysis revealed that the tree topologies of carlaviruses are characterized by two main clades. In particular, on the RdRp region, CapLV-L7 clusters together with NeLV (HipLV isolate) and CVB (Figure 1). The

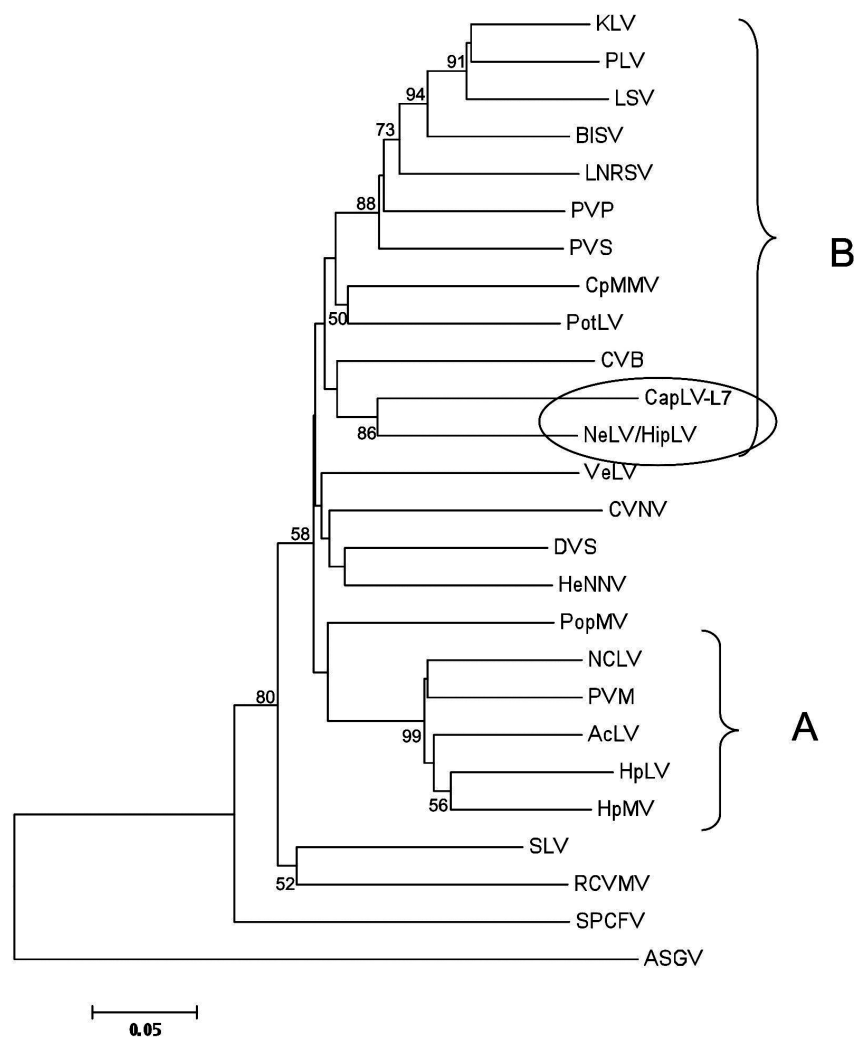

Figure 1. Phylogenetic relationships for amino acid partial sequences of the partial polymerase (ORF1) of the caper carlavirus (CapLV-L7) and other carlaviruses. The tree was bootstrapped using 10,000 replications and only bootstrap values greater than 50% are indicated. See text for full virus names and GenBank accession numbers of their nucleotide sequences.

phylogenetic tree based on the CP gene confirmed the closest relationship with NeLV, as CapLV-L7 falls into the same clade as this virus, while it is quite distant from HVS, the carlavirus serologically related to the Apulia isolate of CapLV (Figure 2).

This study provides the first information on the molecular structure of a carlavirus from caper. The results clearly support the recognition of isolate CapLV-L7 as distinct species within the genus *Carlavirus* according to the molecular demarcation criteria (Adams *et al.*, 2004), by which individual carlavirus species have less than ca.

72% nt identity or 80% aa identity in CP or RdRp genes. CapLV-L7 seems to be different from the caper carlavirus previously identified by Gallitelli and Di Franco (1987), on the basis of its failure to react with polyclonal antisera specific to the Apulia isolate of CapLV and its non sap-transmissibility to *Ch. quinoa* and *N. benthamiana*. No nucleotide sequences of the Apulia isolate CapLV are available. For this reason, our caper carlavirus will be provisionally be considered different from the already identified CapLV species, awaiting results from current studies on a larger number of CapLV isolates from different sources.

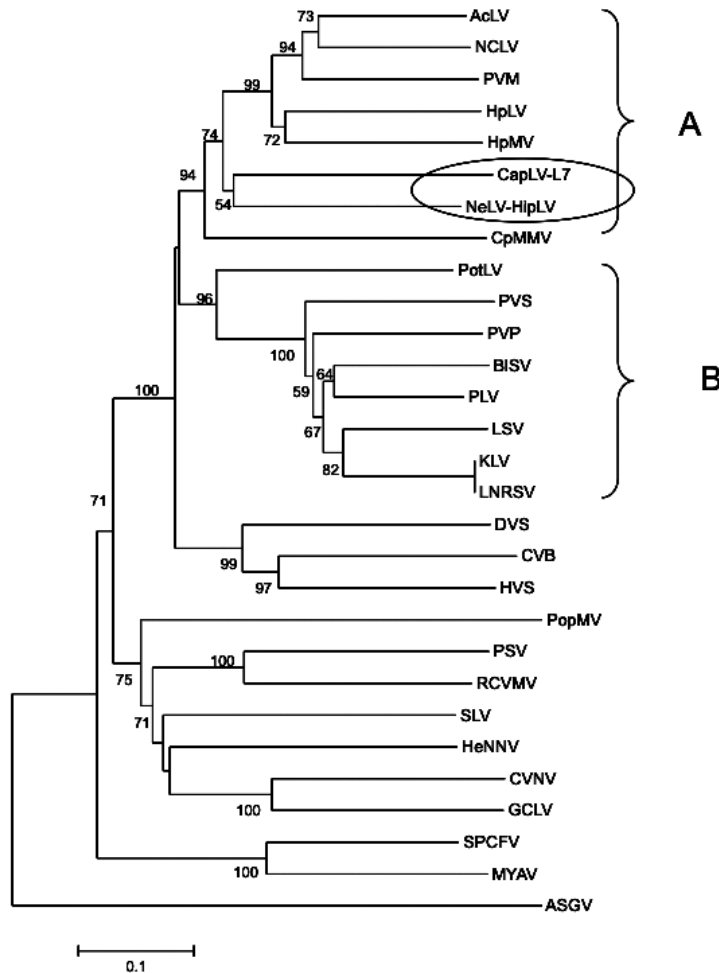

Figure 2. Phylogenetic relationships for amino acid partial sequences of the CP gene (ORF5) of the caper carlavirus (CapLV-L7) and other carlaviruses. The tree was bootstrapped using 10,000 replications. See text for full virus names and Genbank accession numbers of their nucleotide sequences.

Acknowledgements

This study is part of research carried out with a funding grant issued by Regione Sicilia- Italy (2008–2009)

Literature cited

- Adams M.J., J.F. Antoniw, M. Bar Joseph, A.A. Brunt, T. Candresse, G.D. Foster, G.M. Martelli, R.G. Milne and C.M. Fauquet, 2004. The new virus family Flexiviridae and assessment of molecular criteria for species demarcation. *Archives of Virology* 149, 1045–1060.
- Di Franco A. and D. Gallitelli, 1985. Rhabdovirus-like particles in caper leaves with vein yellowing. *Phytopathologia Mediterranea* 24, 234–236.
- Foster G.D., 1998. Carlavirus isolation and RNA extraction. In: *Plant virology protocols: from virus isolation to transgenic resistance. Methods in Molecular Biology* (G.D. Foster and S.C. Taylor ed.) Humana Press, 81, 145–150.
- Gallitelli D. and A. Di Franco, 1987. Characterization of Caper latent virus. *Journal of Phytopatology* 119, 97–105.
- Hataya T., K. Uchino, R. Arimoto, N. Suda, T. Sano, E. Shikata, and I. Uyeda, 2000. Molecular characterization of Hop latent virus and phylogenetic relationships among viruses closely related to carlaviruses. *Archives of Virology* 145, 2503–2524.
- Infantino A., L. Tomassoli, E. Peri and S. Colazza, 2007. Viruses, fungi and insects pests affecting caper. *The European Journal of Plant Science and Biotechnology* 1 (2), 170–179.
- Koonin E.V. and V.V. Dolja, 1993. Evolution and taxonomy of positive-strand RNA viruses: implications of comparative analysis of amino acid sequences. *Critical Review in Biochemistry and Molecular Biology*, 28 (5), 375–430.
- Martelli G.P., M.J Adams, J.F. Kreuze and V. Dolja, 2007. Family Flexiviridae: a case study in virion and genome plasticity. *Annual Review of Phytopathology* 45, 73–100.
- Sher H. and M.N. Alyemeni, 2010. Ethnobotanical and pharmaceutical evaluation of *Capparis spinosa* L, validity of local folk and Unani system of medicine. *Journal of Medicinal Plants Research* 4 (17), 1751–1756.
- Tamura K., Dudley J., Nei M. and Kumar S., 2007. MEGA4: Molecular Evolutionary Genetics Analysis (MEGA) software version 4.0. *Molecular Biology and Evolution* 24, 1596–1599.
- Tomassoli L., A. Zaccaria and M. Barba , 2005. *Capparis spinosa*, a new host of *Cucumber mosaic virus* in Italy. *Plant Pathology* 54, 263.
- Tomassoli L., A. Zaccaria and M. Barba, 2006. Virus distribution and incidence on *Capparis spinosa* L. in Sicilian Islands. In: *Proceedings of the 12th Congress of the Mediterranean Phytopathological Union*, 125–126.

Accepted for publication: July 1, 2011