



**DOCTORAL SCHOOL**  
UNIVERSITA' *MEDITERRANEA* DI REGGIO CALABRIA

DIPARTIMENTO DI INGEGNERIA DELL'INFORMAZIONE, DELLE INFRASTRUTTURE E  
DELL'ENERGIA SOSTENIBILE (DIIES)

PHD IN  
INFORMATION ENGINEERING

S.S.D. ING-INF/03  
XXXIII CICLO

## **NON-TERRESTRIAL NETWORKS IN 5G & BEYOND**

CANDIDATE

Federica RINALDI



ADVISOR

Prof. Giuseppe ARANITI



CO-ADVISOR

Prof. Sergey ANDREEV



COORDINATOR

Prof. Tommaso ISERNIA

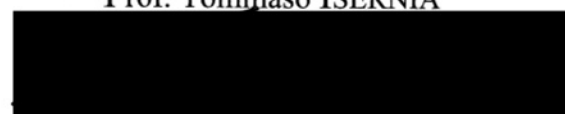

REGGIO CALABRIA, APRIL 2021

Finito di stampare nel mese di **Febbraio 2021**

Edizione  **CSdA** Centro  
Stampa  
d'Ateneo

**Quaderno N. 51**

Collana *Quaderni del Dottorato di Ricerca in Ingegneria dell'Informazione*

Curatore *Prof. Tommaso ISERNIA*

**ISBN 978-88-99352-47-9**

Università degli Studi *Mediterranea* di Reggio Calabria  
Salita Melissari, Feo di Vito, Reggio Calabria

FEDERICA RINALDI

**NON-TERRESTIAL NETWORKS IN 5G & BEYOND**

The Teaching Staff of the PhD course in  
*INFORMATION ENGINEERING*  
consists of:

Tommaso ISERNIA (coordinator)  
Pier Luigi ANTONUCCI  
Giuseppe ARANITI  
Francesco BUCCAFURRI  
Salvatore COCO  
Giuseppe COPPOLA  
Lorenzo CROCCO  
Dominique DALLET  
Claudio DE CAPUA  
Francesco DELLA CORTE  
Giuliana FAGGIO  
Fabio FILIANOTI  
Patrizia FRONTERA  
Sofia GIUFFRÈ  
Giorgio GRADITI  
Voicu GROZA  
Antonio IERA  
Gianluca LAX  
Aimè LAY EKUAKILLE  
Giacomo MESSINA  
Antonella MOLINARO  
Andrea Francesco MORABITO  
Giacomo MORABITO  
Rosario MORELLO  
Domenico ROSACI  
Giuseppe RUGGERI  
Domenico URSINO

*A Papá e Mamma, che mi amano e mi supportano.  
Ad Antonio, che crede in me prima che ci creda io.  
A Lucia, Carmelo e Dylan, che sono i miei migliori amici per la vita.  
A Nonna Lucia, che mi tiene per mano e guida i miei passi.  
A tutti coloro che mi vogliono bene e credono in me.*

\*\*\*\*\*

*To Papá and Mamma, who love and support me.  
To Antonio, who believes in me before I believe in myself.  
To Lucia, Carmelo and Dylan, who are my best friends for life.  
To Nonna Lucia, who holds my hand and guides my steps.  
To everyone who loves me and believes in me.*



### Summary.

The evolution of telecommunication technologies, the ever-increasing demand for new services, and the exponential growth of smart devices fuel the development of Non-Terrestrial Network (NTN) systems as an effective solution to complement the Terrestrial Network (TN) in providing services anytime and anywhere. Since covering many verticals (i.e., transport, eHealth, energy, automotive, public safety) and new applications (i.e., maritime, aeronautical, railway) and offering benefits over uncovered or under-served geographical areas, the NTN gains importance in the Fifth-Generation (5G) New Radio (NR) wireless technology. This growing interest in NTN confirms the will to integrate all existing networks in air, space, and on-ground into a unified system to provide service continuity and scalability in 5G & beyond networks. However, managing the ever-increasing demand for certain types of service, handling numerous devices, and integrating space-air-ground networks could be challenging in terms of both capacity and radio spectrum management.

In light of the above, this Ph.D. thesis provides the recent progress in the standardization and development of the Non-Terrestrial Network in 5G NR and beyond technology, reviews the importance of NTN in wireless systems, and investigates new challenges and open issues concerning the management of mobility, propagation delay, and radio resources. In particular, on these last, this work proposes two novel Radio Resource Management (RRM) approaches to provide valid research contributions and innovation to the state-of-art. The Single-Frequency Multi-Beam Transmission (SF-MBT) scheme overcomes the limitations of frequency reuse-based techniques by introducing the SF-MBT, where beams are synchronized in time to perform a simultaneous transmission of a certain service over the same radio resources to avoid inter-beam interference. Finally, to limit inter-radio access network interference, the Cooperative Terrestrial/Non-Terrestrial Network (TN-NTN) scheme exploits the principles of multicast subgrouping to significantly improve the performance of an integrated TN-NTN system, wherein TN-NTN terminals are under both terrestrial and NTN coverage.



## Sommario.

L'evoluzione delle tecnologie di telecomunicazione, la domanda sempre crescente di nuovi servizi e la crescita esponenziale di dispositivi intelligenti alimentano lo sviluppo di sistemi di reti non-terrestri (NTN) come soluzione efficace da integrare alle reti terrestri (TN) per la consegna dei servizi sempre e ovunque. Coprendo molti settori verticali (ad esempio, trasporti, sanità elettronica, energia, automobilistico, sicurezza pubblica) e nuove applicazioni (marittime, aeronautiche, ferroviarie) e offrendo vantaggi su aree geografiche scoperte o sotto-servite, le NTN acquistano importanza nella tecnologia wireless di quinta generazione (5G) New Radio (NR). Questo crescente interesse per le NTN conferma la volontà di integrare tutte le reti esistenti in aria, spazio e terra in un sistema unificato per fornire continuità di servizio e scalabilità nelle reti 5G e oltre. Tuttavia, potrebbe essere difficile gestire la crescente domanda per determinati tipi di servizio, maneggiare numerosi dispositivi e integrare le reti spazio-aria-terra, sia in termini di capacità che di gestione dello spettro radio.

Alla luce di quanto sopra, questa tesi di dottorato di ricerca si focalizza sui recenti progressi nella standardizzazione e nello sviluppo della rete non-terrestre nella tecnologia 5G NR e oltre, esamina l'importanza delle NTN nei sistemi wireless, e indaga nuove sfide e questioni aperte che riguardano la gestione della mobilità, del ritardo di propagazione e delle risorse radio. In particolare, su queste ultime, questo lavoro propone due nuovi approcci di Radio Resource Management (RRM) che offrono validi contributi di ricerca e innovazione allo stato dell'arte. Lo schema Single-Frequency Multi-Beam Transmission (SF-MBT) supera le limitazioni delle tecniche basate sul riuso della frequenza introducendo la trasmissione multi-beam a singola frequenza, dove i beam sono sincronizzati nel tempo per eseguire la trasmissione simultanea di un determinato contenuto sulle stesse risorse radio per evitare interferenza tra beam. Infine, per limitare l'interferenza tra reti di accesso radio, lo schema Cooperative Terrestrial/Non-Terrestrial Network (TN-NTN) sfrutta i principi dei sottogruppi multicast per migliorare significativamente le prestazioni di un sistema TN-NTN integrato, in cui i terminali TN-NTN si trovano sotto la copertura sia terrestre che NTN.



---

# Contents

<b>Acronyms</b> .....	XV
<b>1 Introduction</b> .....	1
<b>2 The Fifth Generation Technology</b> .....	5
2.1 Introduction .....	5
2.2 The 5G System Architecture .....	8
2.2.1 5G NR Overall Architecture .....	8
NG-RAN .....	8
5G Core Network .....	10
2.2.2 LTE/NR Dual Connectivity (DC) .....	11
2.2.3 LTE-NR Architecture Options .....	12
2.3 NR Physical Layer .....	13
2.3.1 Waveform and Scalable Numerology .....	13
2.3.2 Modulation Schemes .....	15
2.3.3 Frame Structure .....	16
2.3.4 Multi-Antenna Transmission and Beamforming .....	16
2.3.5 Reference Signals .....	17
2.4 User-Plane Protocols .....	17
2.4.1 Medium Access Control (MAC) .....	18
2.4.2 Radio Link Control (RLC) .....	20
2.4.3 Packet Data Convergence Protocol (PDCP) .....	20
2.4.4 Service Data Adaptation Protocol (SDAP) .....	21
2.5 Control-Plane Protocols .....	21
2.6 Performance Evaluation of 5G NR .....	22
2.7 Future Research Directions .....	26
2.8 Conclusions .....	26

<b>3</b>	<b>Non-Terrestrial Networks</b> .....	27
3.1	General Description .....	27
3.1.1	Motivation and Contributions .....	28
3.2	NTN Characteristics and Applications .....	32
3.2.1	NTN General Description .....	32
3.2.2	5G NTN Use Cases .....	33
3.3	NTN Architectures .....	35
3.3.1	Satellite Access Architectures .....	35
3.3.2	Relay-like Architectures .....	38
3.3.3	Service Continuity & Multi-Connectivity .....	38
3.4	Role of Non-Terrestrial Networks in Cellular Communications .....	41
3.4.1	Satellite Network Roadmap .....	41
3.4.2	Satellites in 3G UMTS Systems .....	42
3.4.3	Satellites in 4G Systems .....	44
3.5	Non-Terrestrial Networks in 5G Systems .....	47
3.6	Current 3GPP Research Activities .....	56
3.7	Open Issues and Future Directions .....	58
3.7.1	Mobility Management .....	60
3.7.2	Propagation Delay Management .....	63
3.7.3	Radio Resource Management .....	64
3.8	Toward 6G Satellite Communications .....	65
3.9	Conclusions .....	68
<b>4</b>	<b>Broadcasting Services over 5G NR Enabled Multi-Beam Non-Terrestrial Networks</b> .....	69
4.1	Introduction .....	69
4.2	State-of-the-Art Review .....	71
4.2.1	Motivation .....	71
4.2.2	Related Work .....	72
4.2.3	Our Contributions .....	74
4.3	System Model .....	75
4.3.1	5G NR Multi-Beam NTN Model .....	75
4.3.2	Channel Model .....	77
4.4	Proposed SF-MBT Scheme .....	79
4.4.1	General Description .....	79
4.4.2	Step-by-Step Implementation .....	80
4.4.3	Complexity Analysis .....	83

4.5	Performance Evaluation .....	84
4.5.1	Simulation Model .....	84
4.5.2	Analysis of Results .....	86
	Performance Results in Case A.....	86
	Performance Results in Case B.....	89
4.6	Conclusion .....	93
<b>5</b>	<b>Resource Allocation for eMBB Service Delivery in Integrated 5G NR Cooperative Terrestrial-Satellite Networks.....</b>	<b>95</b>
5.1	Introduction .....	95
5.2	Related Works .....	96
5.3	5G NR TN-NTN System Model .....	97
5.4	The Proposed Cooperative TN-NTN Approach .....	100
5.5	Performance Evaluation .....	103
5.5.1	Simulation Model .....	103
5.5.2	Analysis of Results .....	104
	<b>Performance Results in Case A</b> .....	<b>105</b>
	<b>Performance Results in Case B</b> .....	<b>106</b>
	<b>Performance Results in Case C</b> .....	<b>106</b>
5.6	Conclusions .....	108
<b>6</b>	<b>Conclusions.....</b>	<b>109</b>
	<b>References.....</b>	<b>113</b>
	<b>List of Publications .....</b>	<b>129</b>



---

## Acronyms

1G First Generation.

2G Second Generation.

3G Third Generation.

3GPP Third Generation Partnership.

4G Fourth Generation.

5G Fifth Generation.

5G PPP 5G Infrastructure Public Private Partnership.

5GC 5G Core Network.

5G-EIR 5G-Equipment Identity Register.

6G Sixth Generation.

ADR Aggregate Data Rate.

AF Application Function.

ALJC Application-Layer Joint Coding.

AM Acknowledged Mode.

AMC Adaptive Modulation and Coding.

AMF Access and Mobility Management Function.

ARQ Automatic Repeat Request.

AS Access Stratum.

AUSF Authentication Server Function.

BCCH Broadcast Control Channel.

BCH Broadcast Channel.

BSR Buffer Status Reporting.

BWA Bandwidth Part Adaptation.

BWP Bandwidth Part.

CCCH Common Control Channel.

CHF CHarging Function.

CMS Conservative Multicast Scheme.

CN Core Network.

CORESET Control Resource Set.

CP Control Plane.

CPF Control Plane Function.

CP-OFDM Orthogonal Frequency Division Multiplexing with Cyclic Prefix.

CQI Channel Quality Indicator.

CRI Channel State Information - Reference Signal Resource Indicator.

CSI Channel State Information.

CSI-RS Channel-State Information Reference Signal.

CSIT Channel State Information at the Transmitter.

D2D Device-to-Device.

DC Dual Connectivity.

DCA Dynamic Channel Allocation.

DCCH Dedicated Control Channel.

DFT-s-OFDM Discrete Fourier Transform-spread-Orthogonal Frequency Division  
Multiplexing.

DL Downlink.

DL-SCH Downlink Shared Channel.

DMRS Demodulation Reference Signal.

EC Edge Computing.

eLTE enhanced LTE.

eMBB enhanced Mobile Broadband.

eMBMS evolved MBMS.

eNB LTE NodeB.

EPC Evolved Packet Core.

ESA European Space Agency.

E-UTRA Evolved-Universal Terrestrial Radio Access.

E-UTRAN Evolved-Universal Terrestrial Radio Access Network.

FDD Frequency Division Duplex.

FeMBMS Further evolved MBMS.

FR Frequency Range.

FSS Fixed Satellite System.

GEO Geostationary Earth Orbit.  
GEO-sat GEO Satellite equipped with a transparent payload.  
GMR GEO Mobile Radio.  
gNB 5G NodeB.  
GoS Grade of Service.  
GSM Global System for Mobile Communications.

HAPS High Altitude Platform System.  
HARQ Hybrid - Automatic Repeat Request.  
HMAA Home Mobile-Agent-Anchor.  
HTC Holographic Type Communications.  
HTS High Throughput Satellite.

IAB Integrated Access and Backhaul.  
ICI Inter-Carrier Interference.  
ICT Information and Communications Technology.  
IMR Intermediate Module Repeater.  
IMT-2020 International Mobile Telecommunications 2020.  
INI Inter-Numerology Interference.  
IoRT Internet of Remote Things.  
IoST Internet of Space Things.  
IoT Internet of Things.  
IoV Internet of Vehicles.  
ISL Inter-Satellite Link.  
ITU International Telecommunication Union.

KPI Key Performance Indicator.

LCG Logical Channel Group.  
LCP Logical Channel Prioritization.  
LEO Low Earth Orbit.  
LI Layer Indicator.  
LIS Large Intelligence Surface.  
LMAA Local Mobile-Agent-Anchor.  
LMS Land Mobile Satellite.  
LoS Line of Sight.  
LTE Long-Term Evolution.

M2M Machine-to-Machine.

## XVIII Acronyms

MBA MBSFN Beam Area.  
MBMS Multimedia Broadcast Multicast Service.  
MCG Master Cell Group.  
MCS Modulation and Coding Scheme.  
MEO Medium Earth Orbit.  
MIMO Multiple Input Multiple Output.  
MLA Multicast Link Adaptation.  
mMTC massive Machine-Type Communications.  
mm-Wave millimeter-Wave.  
MN Master Node.  
MR-DC Multi-Radio Dual-Connectivity.  
MS Multicast Subgrouping.  
MS-MSI Multicast Subgrouping – Maximum Satisfaction Index.  
MSS Mobile Satellite System.  
MU-MIMO Multi-User Multiple Input Multiple Output.

NAS Non-Access Stratum.  
NEF Network Exposure Function.  
NFV Network Function Virtualization.  
ng-eNB New-Generation LTE NodeB.  
NGEN-DC Next-Generation Dual-Connectivity.  
NG-RAN Next-Generation Radio Access Network.  
NGSO Non-Geostationary Orbit.  
NOMA Non-Orthogonal Multiple Access.  
NR New Radio.  
NRF Network Repository Function.  
NSSAAF Network Slice-Specific Authentication and Authorization Function.  
NSSF Network Slice Selection Function.  
NTN Non-Terrestrial Network.  
NTN-gNB Non-Terrestrial Network Base Station.  
NWDAF Network Data Analytics Function.

OFDM Orthogonal Frequency Division Multiplexing.  
OMA Orthogonal Multiple Access.  
OMS Opportunistic Multicast Scheme.

PBCH Physical Broadcast Channel.  
PCCH Paging Control Channel.

PCF Policy Control Function.  
PCH Paging Channel.  
PDCCH Physical Downlink Control Channel.  
PDSCH Physical Downlink Shared Channel.  
PDU Packet Data Unit.  
PEI Permanent Equipment Identifier.  
PLMN Public Land Mobile Network.  
PMI Precoding Matrix Indicator.  
PRACH Physical Random Access Channel.  
PRB Physical Resource Block.  
PRS Positioning Reference Signal.  
PSS Primary Synchronization Signal.  
PtM Point-to-Multipoint.  
PtP Point-to-Point.  
PTRS Phase-Tracking Reference Signal.  
PUCCH Physical Uplink Control Channel.  
PUSCH Physical Uplink Shared Channel.

QFI QoS Flow Identifier.  
QH Queuing oh Handover.  
QoS Quality of Service.

RACH Random Access Channel.  
RAN Radio Access Network.  
RAT Radio Access Technology.  
RB Resource Block.  
RI Rank Indicator.  
RLC Radio Link Control.  
RRM Radio Resource Management.  
RTD Round Trip Delay.

S/T-UMTS Satellite-Terrestrial UMTS.  
SA System Aspects.  
SAGIN Space-Air-Ground Integrated Network.  
SBA Synchronized Beam Area.  
SCG Secondary Cell Group.  
SCS Sub-Carrier Spacing.  
SDAP Service Data Adaptation Protocol.

XX Acronyms

S-DMB Satellite-Digital Multimedia Broadcasting.  
SDN Software Defined Networking.  
SDU Service Data Unit.  
SF-MBT Single-Frequency Multi-Beam Transmission.  
SMF Session Management Function.  
SN Secondary Node.  
SNo Sequence Number.  
SO Segment Offset.  
SR Scheduling Request.  
SRB Signaling Radio Bearer.  
SRI Satellite Radio Interface.  
SRS Sounding Reference Signal.  
SSBRI SS/PBCH Block Resource Indicator.  
SSS Secondary Synchronization Signal.  
SUL Supplementary Uplink.  
S-UMTS Satellite UMTS.  
SW-CDMA Satellite Wide-band Code Division Multiplexing Access.

TDD Time Division Duplex.  
TM Transparent Mode.  
TN-NTN Terrestrial/Non-Terrestrial Network.  
T-RAN Terrestrial Radio Access Network.  
TSG Technical Specification Group.  
TTI Transmission Time Interval.

UAS Unmanned Aircraft Systems.  
UCMF UE radio Capability Management Function.  
UDM Unified Data Management.  
UDR Unified Data Repository.  
UDSF Unstructured Data Storage Function.  
UL Uplink.  
UL-SCH Uplink Shared Channel.  
UM Unacknowledged Mode.  
UMTS Universal Mobile Telecommunications System.  
UP User Plane.  
UPF User Plane Function.  
URLLC Ultra-Reliable Low Latency Communications.

VAC Virtual Agent Cluster.

VoD Video-on-Demand.

WCDMA Wide-band Code Division Multiplexing Access.



---

## List of Figures

2.1	5G overall architecture. . . . .	8
2.2	NG-RAN. . . . .	9
2.3	gNB architecture with separation of gNB-CU-CP and gNB-CU-UP. . . . .	9
2.4	High-level representation of the 5G Core Network. . . . .	10
2.5	LTE-NR architecture options. . . . .	11
2.6	User-plane protocol stack architecture. . . . .	18
2.7	Channels mapping. . . . .	19
2.8	Control-plane protocol stack architecture. . . . .	22
2.9	Useful bits per PRB under varying CQI. . . . .	23
2.10	Peak Data Rate for (a) FR1 and (b) FR2. . . . .	24
2.11	Peak Spectral Efficiency for (a) FR1 and (b) FR2. . . . .	25
3.1	5G NTN use cases. . . . .	34
3.2	Satellite access architectures. . . . .	36
3.3	Relay-like architectures. . . . .	37
3.4	Architectures supporting multi-connectivity and involving transparent payload-based satellite. . . . .	38
3.5	Architectures supporting multi-connectivity and involving regenerative payload-based satellite as distributed unit. . . . .	39
3.6	Architectures supporting multi-connectivity and involving regenerative payload-based satellite. . . . .	40
3.7	Types of handover. . . . .	61
3.8	Role of NTN in 5G and beyond. . . . .	68
4.1	Reference architecture for multi-beam transmission in single-frequency mode. . . . .	75
4.2	Flowchart of our SF-MBT algorithm. . . . .	80

XXIV List of Figures

4.3	ADR for SF-MBT, four-color, and three-color frequency re-use schemes with a varying number of NTN terminals per beam. . . . .	87
4.4	Mean throughput for SF-MBT, four-color, and three-color frequency re-use schemes with a varying number of NTN terminals per beam. . . . .	88
4.5	System spectral efficiency for SF-MBT, four-color, and three-color frequency re-use schemes with a varying number of NTN terminals per beam. . . . .	89
4.6	ADR for SF-MBT, four-color, and three-color frequency re-use schemes with a varying channel bandwidth. . . . .	90
4.7	Mean throughput for SF-MBT, four-color, and three-color frequency re-use schemes with a varying channel bandwidth. . . . .	91
4.8	System spectral efficiency for SF-MBT, four-color, and three-color frequency re-use schemes with a varying channel bandwidth. . . . .	92
5.1	Reference architecture for integrated TN-NTN networks. . . . .	98
5.2	Case A: Performance results under a varying channel bandwidth. . . . .	105
5.3	Case B: ADR under a varying number of TN-NTN terminals. . . . .	106
5.4	Case C: Spectral efficiency under varying TN-NTN terminals distribution. . . . .	107
5.5	Case C: Percentage of allocated RBs under varying TN-NTN terminals distribution. . . . .	107

---

## List of Tables

2.1	Related works on 5G NR. . . . .	7
2.2	LTE-NR combined architecture design. . . . .	12
2.3	Scalable numerology. [1] . . . . .	14
3.1	Comparison of surveys on satellite communications. . . . .	29
3.2	Types of NTN Platforms [2]. . . . .	32
3.3	Classification of research work by common topics for different wireless technologies. . . . .	48
3.4	Summary of past works on NTN by open research topics in 5G & beyond. . . . .	50
3.5	Brief description of published research papers on NTN and satellite communications. . . . .	53
3.6	List of 3GPP Features and Study Items on NTN. . . . .	58
3.7	Open issues in NTN. . . . .	59
3.8	Vision of satellite communications from 1G to 6G. . . . .	66
4.1	Loo distribution parameters for each modeled environment at an elevation angle of $40^\circ$ . . . . .	78
4.2	Markov Chain Matrices $\mathbf{P}$ and state probability vectors $\mathbf{w}$ for each modeled environment at an elevation angle of $40^\circ$ (University of Bradford experimental campaign). . . . .	78
4.3	Notation in Use . . . . .	80
4.4	Main Modeling Parameters [2], [3]. . . . .	85
5.1	Channel model specifications. . . . .	99
5.2	Main Modeling Parameters [3], [2]. . . . .	104



## Introduction

The Fifth Generation (5G) New Radio (NR) wireless system represents the next-generation technology to meet the needs of an ever more demanding mobile market.

The 5G NR [4] provides dissimilar types of service characterized by different requirements: *(i)* enhanced Mobile Broadband (eMBB) for services with high data-rate; *(ii)* massive Machine-Type Communications (mMTC) connecting numerous low-cost, low-power and long-life devices; and *(iii)* Ultra-Reliable Low Latency Communications (URLLC) for two-way transfers between devices under extreme network reliability [5]. To support new services while satisfying the underlying quality requirements, the key enablers of the 5G NR operation are scalable numerology, ultra-lean and beam-centric design, support for low latency, spectrum extension, and forward compatibility.

5G wireless technology includes not only terrestrial networks but also non-terrestrial wireless systems. Indeed, Third Generation Partnership (3GPP) heads towards innovative research topics. Among those, NR to support the Non-Terrestrial Network (NTN) captures the attention of telco and scientific communities since the NTN [2] represents an effective solution to provide services anytime and anywhere.

The NTN plays a key role in 5G & beyond systems by covering many verticals (i.e., transport, eHealth, energy, automotive, public safety) and new applications (i.e., maritime, aeronautical, railway).

The uniqueness of NTN derives from the wide-area coverage that offers benefits over urban and rural areas and in areas unserved or under-served by the terrestrial networks. Therefore, the NTN complements terrestrial networks in meeting the 5G expectations of *service continuity* by providing network access where this is infeasible through terrestrial networks, *service ubiquity* by offering network availability in cases of temporary outage or destruction of a terrestrial network, and *service scalability* by offloading the terrestrial network traffic and supporting multicast/broadcast transmissions [3].

In the past few years, the demand for any service has increased dramatically and will grow further in the coming years. In particular, the Ericsson Mobility Report [6]

forecasts that mobile traffic will grow by 30% annually between 2018 and 2024, and most of this increase will come from video services. This uphill trend is mainly driven by the volume of embedded video in online applications, the growth of Video-on-Demand (VoD) streaming services, the adoption of higher screen resolutions, and the large number of smart devices connected to the mobile network. In this regard, the CISCO Annual Internet Report [7] forecasts that the number of connected devices will be around 26 billion by 2022 and will continue to grow.

In this context, handling numerous devices that require different broadcast services could be challenging in terms of both capacity and radio spectrum management. To boost the system capacity and to efficiently exploit the spectrum, the traditional Fixed Satellite System (FSS) based on single-beam transmissions has evolved into High Throughput Satellite (HTS) [8] technology supporting advanced multi-beam deployments. In multi-beam based satellite scenarios, the radio frequency is re-used, according to the 3GPP color-based frequency re-use schemes [2], across multiple beams to avoid inter-beam interference.

Furthermore, the rapid increase in the number of satellites orbiting Earth confirms the growing interest in NTN. However, various space systems on different orbits remain isolated and disconnected from the ground networks. Therefore, integrating all existing networks in air, space, and on-ground into a unified system (i.e., Space-Air-Ground Integrated Network (SAGIN) [9]) will be essential for current 5G and next-to-come Sixth Generation (6G) networks.

In light of the above, this Ph.D. thesis has the following objectives:

- grasp the recent progress in the 3GPP standardization and development of the NTN in 5G NR and beyond technology;
- review the importance of NTN in wireless systems;
- investigate new challenges and open issues;
- on these last, propose novel approaches to provide valid research contributions and innovation to the state-of-art.

It is worth noting that this Ph.D. thesis has been carried out during 3GPP Release 15 and Release 16, where the 3GPP work on NTN was purely informative. The 3GPP normative work started in Release 17 at the time of finishing writing this Ph.D. thesis.

The remainder of the Ph.D. thesis is organized as follows.

Chapter 2 provides a concise survey of the 5G NR system design and its important features including the overall 5G architecture in Section 2.2.1, the main novelties introduced by the relevant 3GPP specifications on physical layer in Section 2.3 and on the user-/control-plane protocol stacks in Section 2.4 and Section 2.5, respectively.

Furthermore, the impact of scalable numerology on system performance is discussed in Section 2.6 and future research directions are considered in Section 2.7.

Chapter 3 reviews 3GPP NTN features and their potential in satisfying user expectations in 5G & beyond networks. In particular, Section 3.2 provides a general description of the NTN and its use cases. State of the art, current 3GPP research activities, and open issues are investigated to highlight the importance of NTN in wireless communication networks from Section 3.4 to Section 3.7. Future research directions are identified in Section 3.8 to assess the role of NTN in 5G and beyond.

Chapter 4 proposes a novel Radio Resource Management (RRM) scheme, named Single-Frequency Multi-Beam Transmission (SF-MBT), for efficient delivery of the eMBB services over the 5G NR multi-beam NTN systems. Section 4.2 illustrates the state of the art, motivations, and contributions. System and channel models are outlined in Section 4.3. Section 4.4 illustrates the main SF-MBT thinking that is to group beams into the dedicated Beam Areas, wherein a certain content flow is delivered via simultaneous multi-beam transmissions over the same radio resources without causing inter-beam interference. Afterward, the effectiveness of the proposed approach compared to the 3GPP frequency re-use schemes is assessed in Section 4.5 through a simulation campaign that is conducted under different scenarios.

Chapter 5 proposes a cooperative radio resource management scheme that enhances the performance of an integrated Terrestrial/Non-Terrestrial Network (TN-NTN) system based on the emerging 5G NR technology. The main objective of the proposed solution is to mitigate the user (i.e., UE) ping-pong effect between the 5G NodeB (gNB) and the Non-Terrestrial Network Base Station (NTN-gNB), increase the robustness to continuous handovers, and, at the same time, improve the service quality perceived by the User Equipment (UE) deployed at cell-edges (i.e., boost the perceived data rate). Related works are summarized in Section 5.2. The 5G NR TN-NTN system model is described in Section 5.3. Section 5.4 presents the cooperative TN-NTN approach, which exploits the principles of multicast subgrouping to group users under the coverage of both terrestrial cells (i.e., gNB) and NTN cells (i.e., NTN-gNB) and allocates resources to improve the overall network throughput. Section 5.5 shows achieved system-level performance results.

Finally, considerations and future works are summarized in the conclusive chapter.



## The Fifth Generation Technology

*As we enter a new era of next-generation wireless systems represented by 5G NR technology, it is essential to grasp the recent progress in their standardization and development. This chapter offers a concise survey of the 5G NR system design that aims at introducing its features according to the relevant 3GPP specifications. Our focus is set on the flexibility of 5G NR, which refers to its capability to support new services while satisfying the underlying quality requirements. The key enablers of the 5G NR operation are scalable numerology, ultra-lean and beam-centric design, support for low latency, spectrum extension, and forward compatibility. This chapter summarizes these important features by studying the overall 5G architecture and the user-/control-plane protocol stacks specified by 3GPP. Furthermore, the impact of scalable numerology on system performance is discussed. Finally, we also consider future research directions.*

### 2.1 Introduction

The 5G wireless system, whose air interface is known as “New Radio” (NR) [4], represents the most promising next-generation solution to meet the needs of the increasingly demanding mobile market. The 5G NR provides dissimilar types of service characterized by different requirements.

In this regard, the International Telecommunication Union (ITU) [5] defines three macro-categories of use cases: *(i)* eMBB for services with high data-rates; *(ii)* mMTC to connect numerous devices with low cost, low power consumption, and long battery life; and *(iii)* URLLC for low latency two-way transfers between devices under extreme network reliability.

For 5G NR standardization, the 3GPP reconsiders many aspects of a wireless system, e.g., the Key Performance Indicator (KPI) targets, network architecture, Radio Access Network (RAN) functions, and the entire network protocol stack. As a result, 5G NR [10] can provide multiple benefits.

First, an extension of the spectrum range allows NR to support operations in licensed bands from below 1 GHz to 52.6 GHz. At millimeter-Wave (mm-Wave) frequencies, high capacity and extreme data rates are possible, even though higher frequencies introduce limitations in coverage due to increased signal attenuation. Further, scalable numerology [11] represents a major 5G innovation to offer network flexibility. Indeed, NR may adjust its Sub-Carrier Spacing (SCS).

Second, 5G NR is designed ultra-lean to lower interference and increases energy efficiency by reducing always-on transmissions. 5G NR is beam-centric by extending beamforming and multi-antenna schemes from data transmission to control-plane procedures and initial access. 5G NR also ensures forward compatibility as it is prepared for its future evolution in use cases and technologies. Here, the introduction of mini-slots makes 5G NR able to guarantee low-latency requirements (e.g., for URLLC).

Finally, NR extends the concept of carrier aggregation by supporting the so-called Supplementary Uplink (SUL). In contrast to carrier aggregation wherein each Uplink (UL) carrier is associated with a certain Downlink (DL) carrier, in case of SUL, a conventional DL/UL carrier is associated with a supplementary UL carrier operating at lower frequencies. The objective of SUL is to extend UL coverage and increase UL data rates in the case of limited power owing to reduced path loss in low-frequency bands.

In this chapter, we first concisely review the 5G NR system by summarizing the main features of the 38th 3GPP specification series. Then, we analyze the 5G NR system performance under varying channel bandwidth for all numerologies. Our goal is to offer the reader – as a one-stop tutorial that is clear and accessible – an overview of the key 5G NR concepts.

Table 2.1 collects the related 5G NR works and summarizes our contributions. The remainder of the chapter is organized as follows. In Section 2.2, the overall 5G architecture is presented. Then, the 5G NR PHY layer is summed up in Section 2.3. Section 2.4 and Section 2.5 describe the 5G radio protocol architecture for user-plane and control-plane, respectively. The 5G NR system performance is evaluated under different numerologies in Section 2.6, whereas future research directions are illustrated in Section 2.7. Finally, conclusions are drawn in Section 2.8.

**Table 2.1.** Related works on 5G NR.

Year	Publication	Brief description
2016	Zaidi <i>et al.</i> [11]	The paper proposes a flexible physical-layer design based on OFDM with scalable numerology for all link types to satisfy the 5G requirements and support various carrier frequencies and deployments.
2017	Bhushan <i>et al.</i> [4]	The paper investigates the key features of the 5G NR air interface, such as waveforms, multiple access techniques, forward compatibility, and advanced technologies to improve performance and efficiency.
2017	Parkvall <i>et al.</i> [10]	The paper provides an overview of the key NR technology components including flexible numerology and frame structure, massive Multiple Input Multiple Output (MIMO), interworking between high and low frequencies, and ultra-lean communications.
2017	Zaidi <i>et al.</i> [1]	The review focuses on the NR PHY layer components: modulation schemes and channel coding, waveforms and frame structure, reference signals, and multi-antenna transmissions.
2018	Liu <i>et al.</i> [12]	The paper investigates multi-beam operation in NR systems by focusing on initial access and random access procedures, system information, and synchronization mechanisms.
2018	Lin <i>et al.</i> [13]	The paper overviews the 5G physical-layer technology by describing the fundamental NR concepts, such as waveform, numerology, frame structure, modulation and coding, physical channels, and reference signals.
2020	Fuentes <i>et al.</i> [14]	The paper discusses 5G and its potential towards the future by providing a precise evaluation of a wide set of KPIs fulfilling the International Mobile Telecommunications 2020 (IMT-2020) requirements of the ITU.
	<b>Our contributions</b>	<p>This chapter surveys NR by focusing on:</p> <ul style="list-style-type: none"> <li>· the overall architecture of 5G NR and Dual Connectivity (DC) architecture options;</li> <li>· innovations introduced by the NR technology in the user-plane and control-plane protocol stacks;</li> <li>· first-order simulation-based analysis regarding the impact of scalable numerology on 5G NR performance;</li> <li>· future research directions by 3GPP.</li> </ul>

## 2.2 The 5G System Architecture

### 2.2.1 5G NR Overall Architecture

Fig. 3.2(a) illustrates the overall 5G NR architecture comprising Next-Generation Radio Access Network (NG-RAN) and 5G Core Network (5GC) [15].

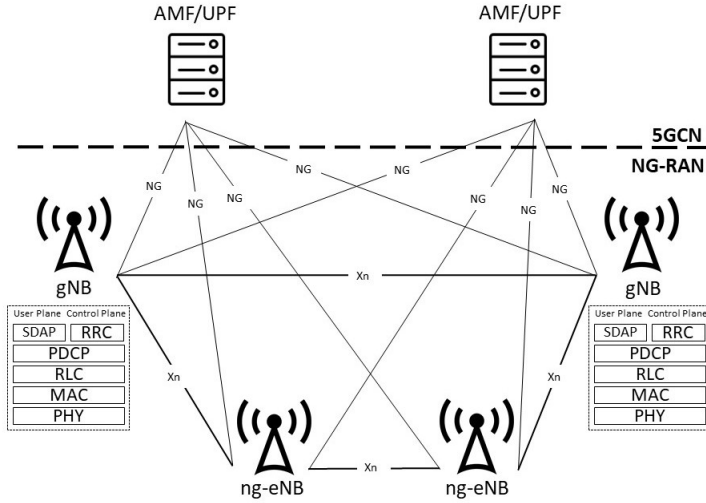

Fig. 2.1. 5G overall architecture.

### NG-RAN

The NG-RAN includes New-Generation LTE NodeB (ng-eNB) and 5G NodeB (gNB), which are responsible for the radio functions, e.g., Radio Resource Management (RRM), admission and connection control, and Quality of Service (QoS) flow management. The ng-eNB employs Evolved-Universal Terrestrial Radio Access (E-UTRA) user-/control-plane protocols to serve LTE UEs and is connected to the 5GC via the NG interface.

Fig. 2.2 depicts the NG-RAN architecture consisting of a set of gNBs [16]. The gNB employs NR user-/control-plane protocols to serve NR UEs and is connected to the 5GC via the NG interface and to other gNBs through the Xn interface.

The gNB consists of a central unit (i.e., gNB-CU) and one or more distributed units (i.e., gNB-DU). One gNB-DU is connected to only one gNB-CU via F1 interface. NG, Xn, and F1 are logical interfaces. The Xn-C interface interconnects gNB-CUs of different gNBs. The gNB can also consist of a gNB-CU Control Plane (CP) (gNB-CU-CP), multiple gNB-CU User Plane (UP) (gNB-CU-UPs) and multiple gNB-DUs.

Fig. 2.3 illustrates the overall architecture with separation of the control-plane and the user-plane for the gNB-CU (i.e., gNB-CU-CP and gNB-CU-UP) [16].

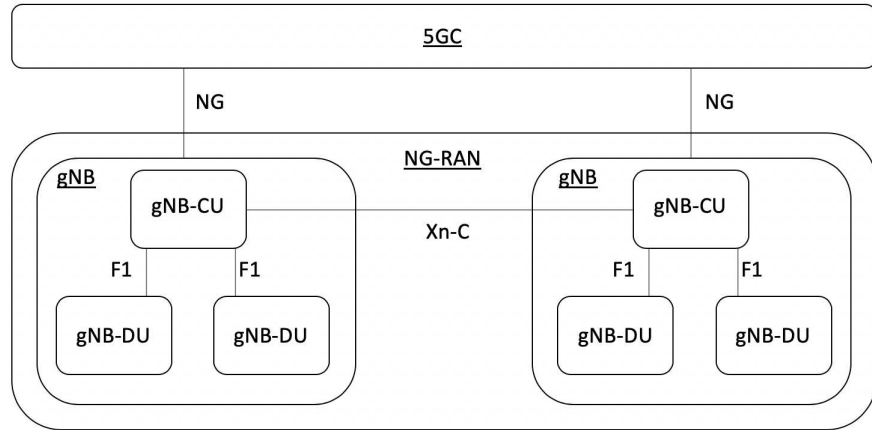

Fig. 2.2. NG-RAN.

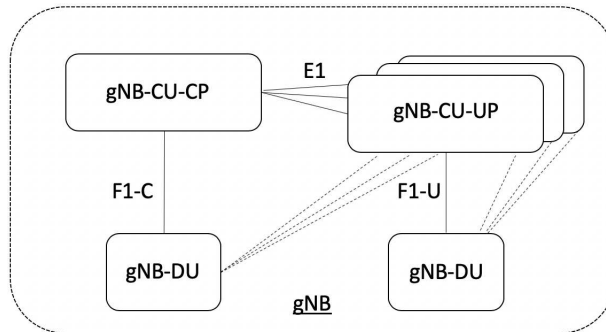

Fig. 2.3. gNB architecture with separation of gNB-CU-CP and gNB-CU-UP.

The gNB-CU-CP is connected to the gNB-DU through the F1-C interface. A gNB-CU-UP is connected to the gNB-DU through the F1-U interface and to only one gNB-CU-CP through the E1 interface. The gNB-CU-UP is connected to only one gNB-CU-CP, to multiple gNB-CU-UPs and multiple gNB-DUs under the control of the same gNB-CU-CP.

The NG-RAN offers new functions, such as: *(i)* network slicing, *(ii)* contacting UEs in inactive mode, *(iii)* handover between E-UTRA and NR via a direct interface between LTE NodeB (eNB) and gNB, *(iv)* handover between E-UTRA and NR via Core Network (CN), *(v)* session management, and *(vi)* tight interworking between NR and E-UTRA, and dual connectivity [17]. In Section 2.2.2, we offer further details regarding dual connectivity.

## 5G Core Network

Fig. 2.4 shows the high-level representation of the 5GC. Detailed descriptions (i.e., reference architecture type, reference points, and point-to-point interactions between the functions) are provided in the specification [18].

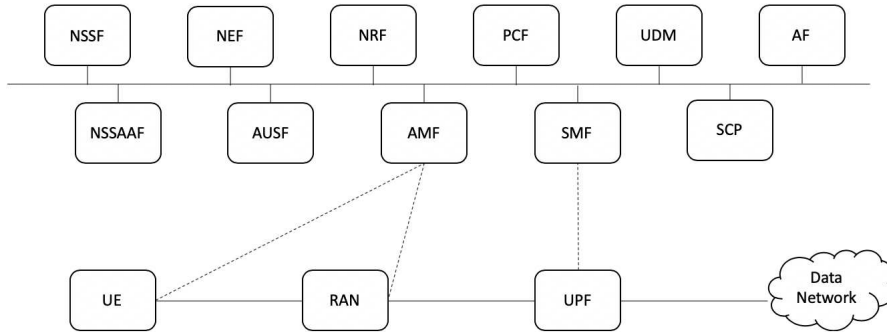

**Fig. 2.4.** High-level representation of the 5G Core Network.

The 5GC follows a service-based architecture, supports network slicing, and splits the user-plane and the control-plane. The *User Plane Function (UPF)* acts as a gateway to connect the RAN to external networks. In certain cases, it also represents the anchor point for intra-/inter-Radio Access Technology (RAT) mobility. The UPF is responsible for packet routing, forwarding, and inspection, handling QoS, and managing traffic measurements.

*Control Plane Function (CPF)* are as follows. The *Session Management Function (SMF)* handles session management and establishment, allocates IP addresses to the UEs, facilitates roaming, and controls the UPF. The *Access and Mobility Management Function (AMF)* manages registration, reachability, mobility, connection, and location services. The AMF also handles access authentication and authorization, and facilitates idle-state mobility. The *Non-Access Stratum (NAS)* operates in-between the AMF and the device, while the *Access Stratum (AS)* operates in-between the device and the RAN.

Other types of functions and entities are: *Unified Data Management (UDM)* that authenticates and authorizes access, *Policy Control Function (PCF)* providing policy rules, *Authentication Server Function (AUSF)* handling authentication, *Application Function (AF)* influencing the traffic routing, *Network Exposure Function (NEF)* providing secure information from external application to 3GPP network, *Network Repository Function (NRF)* supporting service discovery function, *Unified*

*Data Repository (UDR)* responsible of storage and retrieval of subscription data by UDM, *Unstructured Data Storage Function (UDSF)* responsible of storage and retrieval of unstructured data by any network function, *Network Data Analytics Function (NWDAF)* managing network analytics, *Network Slice-Specific Authentication and Authorization Function (NSSAAF)* and *Network Slice Selection Function (NSSF)* in charge of Network Slicing, *UE radio Capability Management Function (UCMF)* storing all UE Radio Capability ID, *5G-Equipment Identity Register (5G-EIR)* checking the status of Permanent Equipment Identifier (PEI) (e.g., whether it has been blacklisted), and *CHarging Function (CHF)* that manages charging information. Details of these functions can be found in [18].

### 2.2.2 LTE/NR Dual Connectivity (DC)

Dual connectivity has been defined in LTE Release 12 [19] as the operation wherein at least two different eNBs, one Master Node (MN) connected to a Secondary Node (SN), offer radio resources to a certain UE. Radio resource aggregation improves per-user throughput and mobility robustness since UEs may be scheduled via multiple eNBs.

NR dual connectivity operates for nodes belonging to two different RATs, that is, the gNB and the eNB provide NR and E-UTRA/NR access, respectively. This results in tight interworking between the two radio technologies and allows NR to gradually fit into the existing LTE networks. In fact, NR access network may operate in two modes: *non-standalone* and *standalone*. Non-standalone operation offers the possibility to connect NR in the existing LTE networks, thus speeding up 5G roll-out. Conversely, standalone operation expects the connection of NR to the 5GC as well as that of LTE to the 5GC. Fig. 2.5 illustrates all standalone and non-standalone architecture options. Further details are provided in the next subsection.

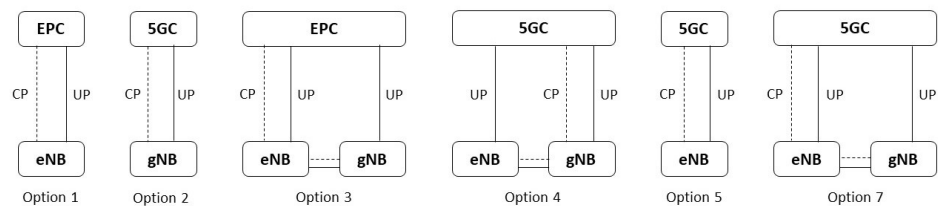

**Fig. 2.5.** LTE-NR architecture options.

### 2.2.3 LTE-NR Architecture Options

In Release 15 [17], 3GPP standardized a combined architecture design. Table 2.2 demonstrates different options for the two core networks, i.e., 5GC and Evolved Packet Core (EPC), and the two RATs, i.e., NG-RAN and Evolved-Universal Terrestrial Radio Access Network (E-UTRAN).

**Table 2.2.** LTE-NR combined architecture design.

DC architecture	Core Network	Master Node	Secondary Node	Terminology
Option 1	EPC	eNB	-	LTE/ EPC
Option 2	5GC	gNB	-	NR/ 5GC
Option 3	EPC	eNB	gNB	EN-DC
Option 4	5GC	gNB	eNB	NE-DC
Option 5	5GC	eNB	-	eLTE
Option 7	5GC	eNB	gNB	NGEN-DC

Option 1 represents the “legacy” LTE/EPC operation, where the eNB is directly linked to the LTE core network. In option 2, the gNB is directly linked to the 5GC in the standalone mode.

In non-standalone option 3, the NG-RAN supports E-UTRAN-NR Dual Connectivity (EN-DC), where UE is connected to one eNB (MN) and one gNB (SN). The eNB is connected to the EPC via the S1 interface and to the gNB via the X2 interface. The gNB can also be connected to the EPC via the S1-U interface and other gNBs via the X2-U interface.

Various combinations of eNB-5GC connections are in options 4, 5, and 7. In option 4, the NG-RAN supports the NR–E-UTRAN Dual Connectivity (NE-DC); hence, the gNB (MN) is linked to the 5GC and to the eNB (SN). Options 5 and 7 are two variants of LTE linked to 5GC. The architecture option 5 is known as enhanced LTE (eLTE), whereas the architecture option 7 as Next-Generation Dual-Connectivity (NGEN-DC).

The NG-RAN also supports NR-NR Dual Connectivity (NR-DC) when a gNB (MN) is linked to the 5GC and to another gNB (SN). In addition, NR-DC can also be used when a UE is connected to two gNB-DUs, one serving the Master Cell Group (MCG) and the other serving the Secondary Cell Group (SCG), connected to the same gNB-CU, acting both as a MN and as a SN.

## 2.3 NR Physical Layer

The NR PHY layer [1] is in charge of UL synchronization and timing control, multiplexing and channel coding, link adaptation, power control, random access procedures, multi-antenna mapping and processing, and beam management. It transfers information towards the higher layer (i.e. Medium Access Control or MAC) through transport channels as well as handles the mapping of transport channels to physical channels.

The physical channels defined for NR are the following.

- *Physical Broadcast Channel (PBCH)* carries system information for devices access to the network.
- *Physical Downlink Control Channel (PDCCH)* is used for control information, such as scheduling decisions.
- *Physical Downlink Shared Channel (PDSCH)* is the main channel for unicast data transmissions regarding paging, random access, and system information.
- *Physical Uplink Control Channel (PUCCH)* carries information about Hybrid - Automatic Repeat Request (HARQ), received transport blocks, channel state reports, and radio resource requests.
- *Physical Uplink Shared Channel (PUSCH)* is the counterpart to the PDSCH.
- *Physical Random Access Channel (PRACH)* is used for random access.

The system operates from below 1 to 52.6 GHz in frequency ranges FR1 and FR2 [20]. The choice of a Frequency Range (FR) depends on the base station deployment. At lower frequencies, wider coverage areas are available (i.e., macro-cells), whereas coverage is more limited at higher frequencies (i.e., micro- and pico-cells). The licensed spectrum provides higher quality and reliability. In contrast, the unlicensed spectrum complements by offering higher data rates and improved capacity.

The main NR physical-layer components [1] are waveforms and scalable numerology, modulation schemes, frame structure, multi-antenna transmission and beamforming, and reference signals, which are described in the following subsections.

### 2.3.1 Waveform and Scalable Numerology

The 5G NR PHY layer supports the Orthogonal Frequency Division Multiplexing with Cyclic Prefix (CP-OFDM) in the DL and CP-OFDM and Discrete Fourier Transform-spread-Orthogonal Frequency Division Multiplexing (DFT-s-OFDM) with cyclic prefix in the UL. The scalable Orthogonal Frequency Division Multiplexing (OFDM) numerology introduced by NR specifies SCS, Transmission Time Interval

(TTI), cyclic prefix, and the number of slots. In particular, higher numerology indexes correspond to larger SCSs, ranging from 15 and 480 kHz by following the equation:

$$\Delta f = 15 \text{kHz} \times 2^\mu. \quad (2.1)$$

The numerology index  $\mu$  depends on various factors (i.e., service requirements, deployment type, carrier frequency, etc.). The introduction of wider SCS is essential for mitigating Inter-Carrier Interference (ICI) and phase noise at mm-Wave frequencies. As SCS widens, the TTI assumes smaller values ranging from 1 ms to 31.25  $\mu\text{s}$ . Other parameters also change from numerology to numerology. Further details are provided in Table 2.3.

**Table 2.3.** Scalable numerology. [1]

$\mu$	$\Delta f$ [KHz]	TTI [ $\mu\text{s}$ ]	No. Symbols per slot	Cyclic Prefix duration [ $\mu\text{s}$ ]
0	15	1000	7, 14	4.69
1	30	500	7, 14	2.34
2	60	250	7, 14	1.17
3	120	125	2, 4, 7, 14	0.58
4	240	62.5	2, 4, 7, 14	0.29
5	480	31.25	2, 4, 7, 14	0.14

Bandwidth is managed in terms of Physical Resource Block (PRB), each consisting of 12 subcarriers with a certain SCS. The number of PRBs depends on the channel bandwidth and SCS that are specified for FR1 and FR2 [20].

DL and UL transmissions occur when at least one PRB is assigned to a UE. The radio resource allocation is managed by the gNB after performing the channel sounding that acquires the knowledge of the radio channel characteristics. Each UE sends its radio channel information to the gNB in the Channel State Information (CSI) [21] feedback. The CSI consists of the Channel Quality Indicator (CQI), Precoding Matrix Indicator (PMI), Channel State Information - Reference Signal Resource Indicator (CRI), SS/PBCH Block Resource Indicator (SSBRI), Layer Indicator (LI), Rank Indicator (RI), and/or L1-RSRP.

In particular, the CQI is associated with the maximum supported Modulation and Coding Scheme (MCS).  $R_{min,PRB}$  is the minimum data rate per PRBs expressed in kbps, which is computed as:

$$R_{min,PRB} = \frac{CR}{1024} \times M_{order} \times N_{symp} \times N_{subcarrier}, \quad (2.2)$$

where  $CR$  is the code rate  $\times 1024$ ,  $M_{order}$  is the modulation order (i.e., 2 for QPSK, 4 for 16-QAM, 6 for 64-QAM, and 8 for 256-QAM),  $N_{syms}$  is the number of symbols that can assume values ranging from 2 to 14 (see Table 2.3), and  $N_{subcarrier} = 12$  is the number of subcarriers in a PRB.

Finally,  $B_\mu$  is the number of bits carried by a single PRB, which can be computed as:

$$B_\mu [bit] = \frac{R_{min,PRB,bps}}{N_{slot,s}} = \frac{R_{min,PRB} \times 10^3}{10^3 \times 2^\mu}, \quad (2.3)$$

where  $R_{min,PRB,bps}$  is the minimum data rate per PRB expressed in bps and  $N_{slot,s}$  is the number of slots per second that depends on the numerology. As a consequence,  $B_\mu$  is a function of the numerology. Hence, as the SCS widens, each PRB contains fewer useful bits and more overhead with respect to the PRBs of lower numerology. This develops robustness against the phase noise when operating at extremely high frequencies.

The introduction of scalable numerology allows the 5G NR to take advantage of wider carrier bandwidths. This may cause higher device energy consumption. To cope with it, in NR each device monitors only a portion of the radio spectrum. When needed, the device can monitor the full bandwidth owing to the *receiver-bandwidth adaptation*. Receiving a portion or the full carrier bandwidth is the reason to introduce the concept of Bandwidth Part (BWP), which is a fixed band over which transmissions employ the same numerology and is defined in [22] as a subset of contiguous common resource blocks for a given numerology  $\mu_i$  in bandwidth part  $i$  on a given carrier. Two possible configurations of sub-band size are eligible for BWP [21]. The total bandwidth consists of several BWPs. Furthermore, a BWP correlates the numerology and the scheduling mechanism. Indeed, the gNB can modify the UE numerology by changing the BWP through the Bandwidth Part Adaptation (BWA). Although a UE can be configured with up to four BWPs in the DL and also in the UL, each UE can monitor a single active BWP to reduce power consumption and prolong battery life. Information about the active initial bandwidth part is obtained via the Control Resource Set (CORESET) configuration from the PBCH in the DL, whereas information on the activated initial UL bandwidth part is transferred in the PDCCH.

### 2.3.2 Modulation Schemes

The supported MCSs are QPSK, 16QAM, 64QAM, and 256QAM in the DL and for CP-OFDM in the UL, and  $\pi/2$ -BPSK, QPSK, 16QAM, 64QAM, and 256QAM for DFT-s-OFDM with cyclic prefix in the UL.

### 2.3.3 Frame Structure

The 5G NR frame structure supports Frequency Division Duplex (FDD) operating during transmissions in the paired spectrum, while Time Division Duplex (TDD) is used for the unpaired spectrum. In 5G NR, a subframe is formed by adjacent slots, each comprising 7 or 14 OFDM symbols for  $SCS \leq 60$  kHz and 2, 4, 7, or 14 OFDM symbols for  $SCS \leq 120$  kHz.

The 3GPP standardized 255 symbol combinations, each corresponding to a slot format identified by an index (i.e., slot format index) [23]. Its OFDM symbols can be designated as downlink, uplink, or flexible. A downlink symbol is used only in the DL direction, while no UL transmission occurs in the same time period. On the contrary, an uplink symbol is exploited for the UL without any overlapping transmission in the DL. Flexible symbols can be adapted for transmissions in the DL or in the UL.

5G NR considers mini-slots to be the smallest scheduling units of 2, 4, or 7 symbols, which are especially important for URLLC. The URLLC transmissions are managed with the highest priority by *puncturing* the 1 ms subframe for a mini-slot duration. This enables dynamic scheduling. In the case of extremely low-latency services, the transmission start is not limited to a slot but can occur whenever the radio channel is not occupied by another transmission.

### 2.3.4 Multi-Antenna Transmission and Beamforming

Since 5G NR extends the operating frequency range by comprising the frequency bands below 7 GHz (i.e., FR1) and in the range from 24.25 GHz to 52.6 GHz (i.e., FR2), different antenna solutions and techniques need to be employed depending on the utilized spectrum. For lower frequencies, up to a moderate number of antennas can be activated (i.e., 32). In higher frequency bands, the transmission is characterized by a considerable signal attenuation that limits the network coverage. To overcome this limitation, one of the key features is the adoption of a large number of multi-antenna elements having a given aperture to increase the transmission/reception capability of Multi-User Multiple Input Multiple Output (MU-MIMO) and beamforming.

Since managing transmissions in higher frequency bands is complicated, beam management is necessary to establish the correspondence between the directions of the transmitter- and the receiver-side beams by identifying the most suitable beam pair for both DL and UL. 5G NR offers a new type of beam management, wherein the BS sweeps the candidate radio transmitter beams sequentially in time, while the UE maintains an appropriate radio receiver beam to activate the reception of the selected radio transmitter beam.

To achieve this, beam management consists of the *initial beam establishment* to find the first beam pair, the *beam adjustment* to adapt the beam pair as the device moves, and the *beam recovery* to handle the beam pair failure in case of rapid environmental changes. Hence, the complete beam management functionality establishes, monitors, adjusts, and recovers the beam pair to allow for communication at higher frequencies.

### 2.3.5 Reference Signals

In NR, reference signals are transmitted only if necessary; they are as follows:

- *Demodulation Reference Signal (DMRS)* is UE-specific and measures the radio channel for demodulation to support multiple-layer MIMO transmission and low-latency applications.
- *Phase-Tracking Reference Signal (PTRS)* is UE-specific and is exploited at mm-Wave frequencies to mitigate the phase noise causing phase rotation of subcarriers in an OFDM signal. PTRS compensates for the oscillator phase noise.
- *Channel-State Information Reference Signal (CSI-RS)* is received by the UE to evaluate the channel; further, the channel quality information is transferred to the gNB.
- *Sounding Reference Signal (SRS)* is transmitted by the UE to help the gNB in estimating the CSI for scheduling and link adaptation. SRS is also utilized for reciprocity in massive MIMO and UL beam management.
- *Positioning Reference Signal (PRS)* is a new reference signal that supports DL-based positioning. The UE reports the times of arrival of PRSs transmitted by multiple base stations; in such a way, the location server is able to determine the UE position.
- *Primary Synchronization Signal (PSS)* is a PHY layer-specific signal that helps the UE to get radio frame boundary and to detect the cell identity (ID).
- *Secondary Synchronization Signal (SSS)* is a PHY layer-specific signal that, in addition to the PSS, helps the UE to detect the cell ID group.

## 2.4 User-Plane Protocols

The user-plane protocols [24] facilitate the actual Packet Data Unit (PDU) session service by transporting user data through the access stratum. Fig. 2.6 shows the user-plane protocol stack architecture.

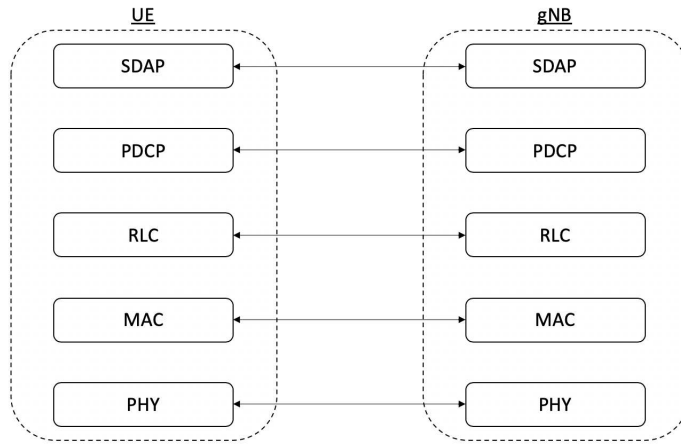

**Fig. 2.6.** User-plane protocol stack architecture.

### 2.4.1 Medium Access Control (MAC)

The MAC layer provides a connection to the Layer 2 Radio Link Control (RLC) layer through various logical channels, each characterized by the type of the transferred information. The control logical channels are:

- *Broadcast Control Channel (BCCH)* transmits system information to all the network devices in the case of standalone operation. For non-standalone operation, there is no BCCH because the system information is provided by the LTE system.
- *Paging Control Channel (PCCH)* is used for paging the devices when their location is unknown by the network in the case of standalone operation. For non-standalone operation, there is no PCCH because paging is provided by the LTE system.
- *Common Control Channel (CCCH)* transmits control information under random access regime.
- *Dedicated Control Channel (DCCH)* is the logical channel used for transmission of the control information to and from a device.

The logical channel related to traffic is *Dedicated Traffic Channel (DTCH)*, which is used for the data transmission to and from a device over a unicast link in the DL or UL, respectively. The PHY layer provides its services to the MAC layer through the transport channels. A transport channel refers to how the information is transferred over the radio interface.

The DL transport channels are:

- *Broadcast Channel (BCH)* is used for the transmission of Master Information Block (MIB) that is a part of the BCCH system information.

- *Downlink Shared Channel (DL-SCH)* is the main channel for DL data transmission in NR and supports its key features, such as dynamic rate adaptation and channel-dependent scheduling.
- *Paging Channel (PCH)* carries paging information from the PCCH channel by saving the battery power of the devices supporting discontinuous reception (DRX).

The UL transport channels are:

- *Uplink Shared Channel (UL-SCH)* is the main channel for UL data transmission.
- *Random Access Channel (RACH)* is another transport channel even though it does not carry transport blocks.

Fig. 2.7 depicts the mapping among physical, transport, and logical channels in both UL and DL directions.

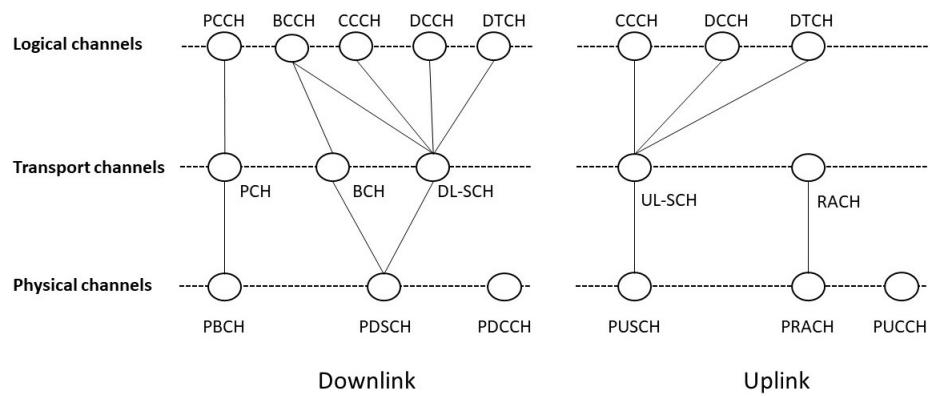

**Fig. 2.7.** Channels mapping.

The MAC layer is responsible for multiplexing/demultiplexing, for managing different numerologies and scheduling, for HARQ retransmissions, and for handling the priority between the UEs via dynamic scheduling. Extended MAC functionality is introduced by 5G NR: e.g., the MAC PDU is changed. MAC elements used for control signaling are at the beginning of the MAC PDU in the DL and the end of the MAC PDU in the UL. Hence, the NR MAC layer header structure is more efficient in supporting low-latency requirements.

The procedure for creating MAC PDUs is known as Logical Channel Prioritization (LCP). In NR, there is also a need for LCP enhancement due to scalable numerology and TTIs, each suited for a specific service type. The LCP handles the mapping of a logical channel onto certain numerology/TTI and includes URLLC traffic prioritization.

Hence, LCP aims to let the MAC entity learn the numerology/TTI from the PHY layer.

Beyond improved PDU format, the NR MAC layer adopts new Scheduling Request (SR) functionality. The SR is utilized to request the UL-SCH resources to establish a data transmission. Different from LTE SR, where a UE supports only one SR resource, the NR MAC entity is configured such that a UE may support zero, one, or more SR configurations, each consisting of multiple PUCCH resources for different BWPs and corresponding to one or more logical channels. A logical channel is configured to support only one PUCCH resource for SR per BWP.

The SR configuration/resource of the logical channel that has triggered a Buffer Status Reporting (BSR), which provides information about UL data volume in the MAC entity to the serving gNB, is considered as the corresponding SR configuration/resource for the triggered SR. Each logical channel may be allocated to a Logical Channel Group (LCG), while the maximum number of LCGs is increased to eight for NR as opposed to 4 LCGs supported by LTE.

#### 2.4.2 Radio Link Control (RLC)

The RLC layer handles data transfer. It offers three transmission options: *(i)* Transparent Mode (TM), *(ii)* Unacknowledged Mode (UM), and *(iii)* Acknowledged Mode (AM). RLC also performs segmentation by considering the Sequence Number (SNo) and the Segment Offset (SO), transfers upper-layer PDUs, corrects errors via Automatic Repeat Request (ARQ), and detects protocol errors.

NR RLC does not order the Service Data Unit (SDU) in sequence to reduce the overall latency; hence, packets can be forwarded towards the upper layers immediately, without waiting for re-transmissions of previously missing packets. Furthermore, to meet the NR latency requirements, NR RLC does not support concatenation (now introduced at the MAC layer). As a result, NR RLC PDUs can be assembled before receiving the scheduling decision. Once the latter is made, the PDUs are transferred to the MAC layer immediately.

#### 2.4.3 Packet Data Convergence Protocol (PDCP)

The PDCP layer is in charge of header compression and decompression, user data transfer, handling re-transmissions, reordering, and detection of duplicates during handover. The re-ordering functionality is moved from RLC to PDCP in NR. The PDCP layer is also in charge of ciphering, deciphering, and integrity protection, as

well as duplication, which is a new PDCP function. Accordingly, user packets are re-transmitted to the gNB several times such that at least one copy is received correctly. If more than a single copy of the same PDU is received, the PDCP removes any duplicates. PDCP duplication is also used (i) in case of transmission via multiple cells to meet high-reliability requirements and (ii) in dual-connectivity scenarios.

#### 2.4.4 Service Data Adaptation Protocol (SDAP)

The challenge of meeting various QoS requirements has already been addressed by LTE. However, QoS handling in NR needs to be improved under network slicing. Hence, a new user-plane protocol layer, namely, *Service Data Adaptation Protocol (SDAP)*, was defined to manage QoS when connected to the 5GC. Each PDU session therefore consists of QoS flows and data radio bearers. The IP packets are associated with the QoS flows according to their requirements, and are labeled with an identifier, i.e., QoS QoS Flow Identifier (QFI). Hence, SDAP provides the mapping of a QoS flow from the 5GC and a data radio bearer, while marking the QFI.

The correspondence between QoS flows and data radio bearers in the UL is as follows. Explicit mapping considers the configuration from the QoS flow to the data radio bearer in the device through RRC signaling. Alternatively, reflective mapping is a novel NR functionality when connected to the 5GC. Here, a device observes the QFI in the DL by inferring which IP packets are associated with a QoS flow and a data radio bearer.

## 2.5 Control-Plane Protocols

The control-plane protocols [24] establish PDU sessions and manage connections between the UE and the network mindful of service requests, transmission resources, and handover occurrences.

Fig. 2.8 shows the control-plane protocol stack architecture.

The control-plane stack has the same protocol layers – PHY, MAC, RLC, and PDCP – as described in Section 2.4.

The protocol layer having solely control-plane functionality is *RRC*, which operates between a device and its gNB. It handles the paging procedure initiated by 5GC or NG-RAN. RRC also establishes, maintains, and releases the RRC connection between a UE and NG-RAN by including security functions (i.e., key management), mobility functions (i.e., handover, UE cell selection and reselection, inter- RAT mobility), and

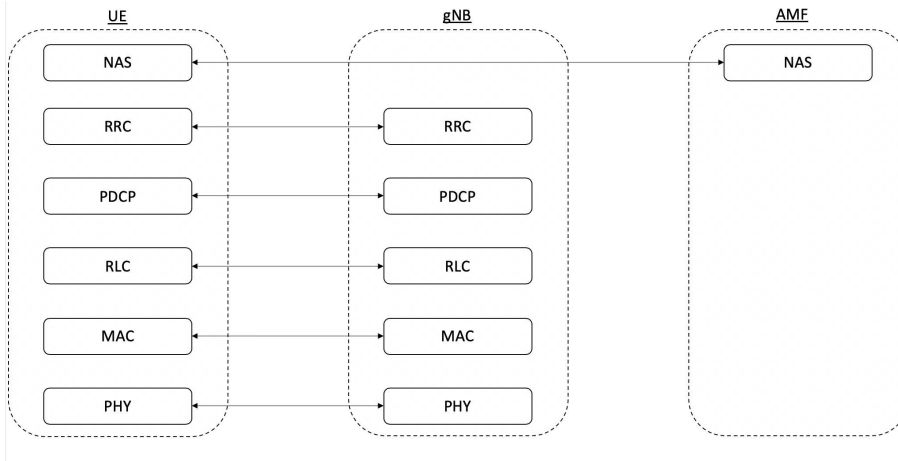

**Fig. 2.8.** Control-plane protocol stack architecture.

QoS management functions. The RRC also helps detect and recover from radio link failures.

Each NR device supports three RRC states, two of which – IDLE and CONNECTED – are the same as in LTE. Moreover, NR introduces INACTIVE as an intermediate state between IDLE and CONNECTED. Further information on RRC state transitions can be found in [24]. With NR, the transmission of messages between RRC and NAS layer occurs owing to Signaling Radio Bearer (SRB), which are:

- SRB0 exploits the CCCH logical channel for RRC messages;
- SRB1 exploits the DCCH logical channel for both RRC and NAS messages before establishing SRB2;
- SRB2 exploits the DCCH logical channel for NAS messages and has a lower priority than SRB1;
- SRB3 exploits the DCCH logical channel for particular RRC messages when UE operates in dual-connectivity mode.

The SRB1 and SRB2 are also used in NR for integrity protection and ciphering as well as support the split of SRB for all Multi-Radio Dual-Connectivity (MR-DC) options. The latter is not available for SRB0 and SRB3. Further, the SRB split and SRB3 are the two new features introduced by NR.

## 2.6 Performance Evaluation of 5G NR

The below simulation results were obtained with our MATLAB tool that follows 3GPP guidelines on 5G NR operations. In this chapter, we characterize the performance of a 5G NR system in terms of *peak data rate* and *peak spectral efficiency* for different

numerologies (i.e.,  $\mu = 0, 1, 2, 3$ ) and under varying channel bandwidth<sup>1</sup>. The selected parameters were evaluated by considering the transmission bandwidth configuration for both FR1 and FR2 [20]. Further, we computed the number of useful bits per PRB for each numerology by considering the CQI- MCS mapping parameters in [21]. The motivation behind this performance analysis is to understand how scalable numerology affects the volume of data carried by a single PRB.

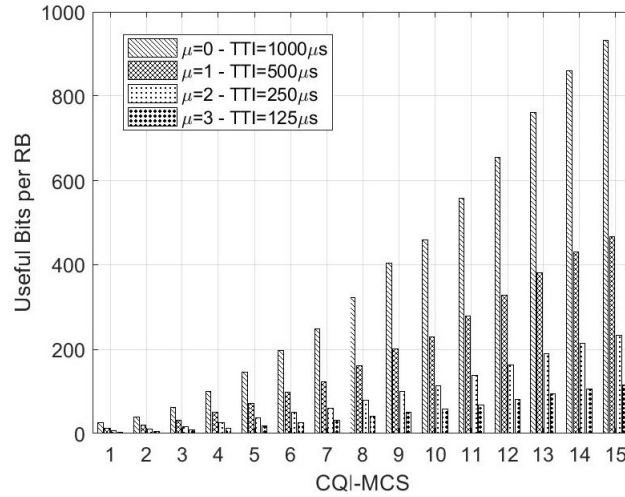

**Fig. 2.9.** Useful bits per PRB under varying CQI.

From this perspective, Fig. 2.9 indicates the number of useful bits per PRB (computed as in eq. (2.3)) for different TTI durations according to the selected numerology when varying the UE channel conditions. As expected, in all cases, the parameter of interest increases with the CQI level, whereas the number of useful bits decreases, for a given CQI, when considering higher numerologies.

Reducing the end-to-end latency is possible by operating at higher frequencies and under high numerologies, wherein OFDM symbol duration is shorter and, consequently, the SCS is wider. Higher frequency also displays more pronounced path-loss degradation: as the signal is attenuated and distorted during its propagation at higher frequencies, wider SCS is required to compensate for the observed effect. Conversely, the peak data rate per TTI decreases for high numerologies when considering fixed bandwidth, as shown in Fig. 2.10. This is because the number of PRBs per TTI becomes lower due

<sup>1</sup> It is worth noting that in 3GPP Release 16 of NR [20], the number of PRBs is specified for numerologies from 0 to 3, whereas the number of PRBs for numerologies 4 and 5 is not available in that release.

to wider SCS with higher numerology. Under increasing channel bandwidth, the peak data rate follows a growing trend due to more PRBs available.

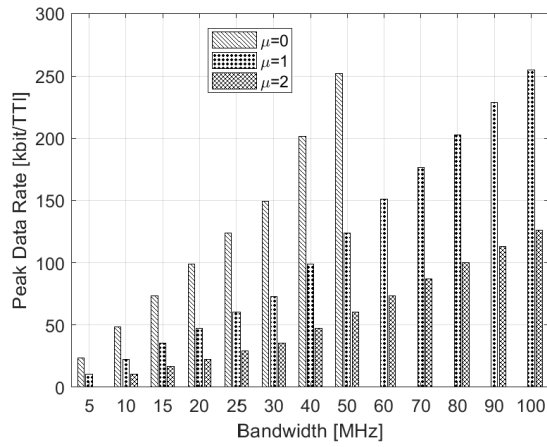

(a) FR1

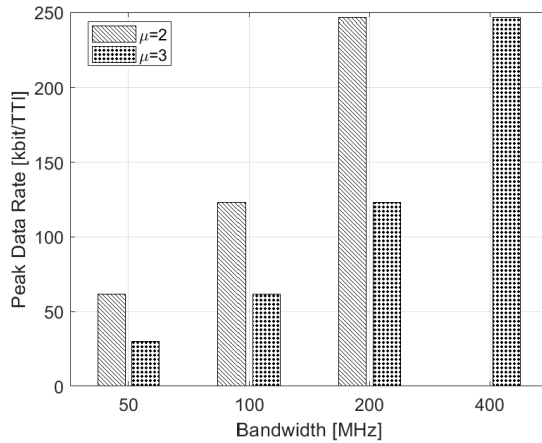

(b) FR2

**Fig. 2.10.** Peak Data Rate for (a) FR1 and (b) FR2.

When considering higher numerologies, a consequence of the peak data rate decrease is the reduction in terms of peak spectral efficiency in a TTI, as shown in Fig. 2.11. Actually, considering higher frequencies leads to more pronounced pathloss phenomena. Since the signal is attenuated and distorted during the propagation on higher frequencies, more overhead bits are needed to compensate for these effects. This means that the radio spectrum is not fully exploited for the delivery of useful data, hence, a reduction in the system spectral efficiency is shown.

By analyzing the obtained results, we establish that: (i) lower numerologies are better suited for eMBB services with their higher volumes of data and without

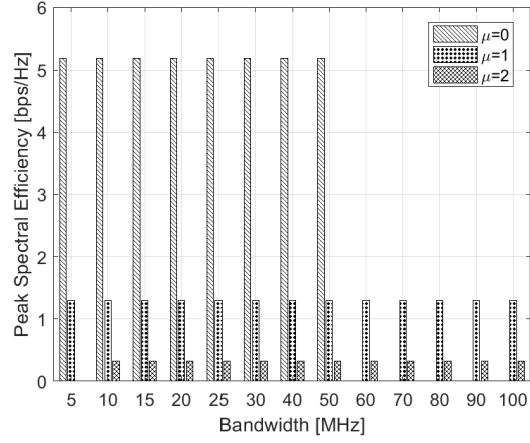

(a) FR1

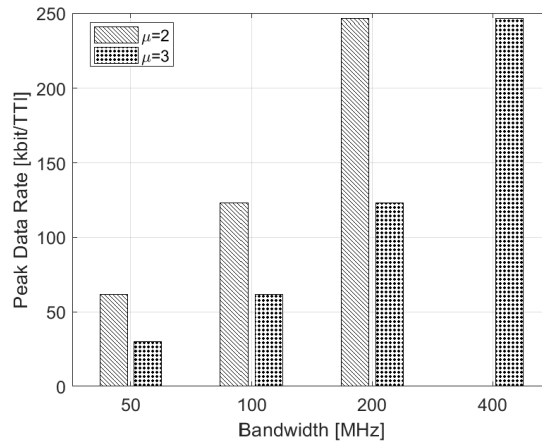

(b) FR2

**Fig. 2.11.** Peak Spectral Efficiency for (a) FR1 and (b) FR2.

the stringent requirements in terms of latency; *(ii)* higher numerologies satisfy the requirement of (ultra-)low latency, which is essential for URLLC, at the expense of some reduction in the peak data rate; *(iii)* higher numerologies can also be exploited at higher frequencies while lower numerologies suit lower frequencies since the number of useful bits per PRB delivered in a TTI decreases under higher numerologies.

As an example, a typical URLLC transmission comprising of few bits (e.g., data exchange between sensors of vehicles for collision avoidance), may occur at higher frequencies, which allows satisfying latency requirements but demands a wider SCS to mitigate the phase noise effect.

## 2.7 Future Research Directions

The mainstream specification work on Release 17 has already started. There are multiple areas to be considered and, realistically, only a subset of them (about 20-30%) can be addressed. On the one hand, many items are completely new, whereas several of those have already been specified in earlier releases and are to be expanded in Release 17. The more innovative topics are the following:

- *NR Light* improves operations of mid-tier NR devices (e.g., higher-end MTC devices like security cameras, wearables, etc.), which includes the power saving aspects.
- *NR above 52.6 GHz* offers the possibility to extend the frequency bands up to 114 GHz by studying suitable waveforms.
- *Multi-SIM operations* are specification enhancements, especially in the area of paging coordination, for more efficient and predictable operations of high numbers of multi-SIM devices.
- *NR multicast/broadcast* supports multicast transmissions by focusing on single-cell multicast functionality with the evolution towards multicell.
- *NR for NTN* defines the requirements, features, and adaptations enabling the operation of the NR protocol in NTN by considering potential impacts on the physical layer and defining solutions.

## 2.8 Conclusions

In this chapter, we surveyed the main 5G NR system design features with the topics covering the key innovative aspects introduced in the system architecture and protocol stack (i.e., PHY layer, user-/control-plane protocols). This information is representative of the latest Releases 16 of the 38th series of 3GPP specifications.

Furthermore, we assessed the system performance by analyzing the results of system-level simulations. Based on these results, we projected useful considerations regarding the impact of scalable numerology on the 5G NR performance. Finally, future research directions were briefly outlined.

## Non-Terrestrial Networks

*5G telecommunication systems are expected to meet world market demands of accessing and delivering services anywhere and anytime. NTN are able to satisfy requests of anywhere and anytime connection by offering wide-area coverage and ensuring service availability, continuity, and scalability. In this chapter, we review 3GPP NTN features and their potential in satisfying user expectations in 5G & beyond networks. State of the art, current 3GPP research activities, and open issues are investigated to highlight the importance of NTN in wireless communication networks. Finally, future research directions are identified to assess the role of NTN in 5G and beyond systems.*

### 3.1 General Description

The evolution of telecommunication technologies, the ever-increasing demand for new services, and the exponential growth of smart devices fuel the development of NTN systems as an effective solution to complement terrestrial networks in providing services over uncovered or under-served geographical areas. As defined by the 3GPP in [2], an NTN is a network where spaceborne (i.e., GEO, MEO, LEO) or airborne (i.e., UAS and HAPS) vehicles act either as a relay node or as a base station, thus distinguishing *transparent* and *regenerative* satellite architectures.

The uniqueness of NTNs is in their capability to offer wide-area coverage by providing connectivity over the regions that are expensive or difficult to cover with terrestrial networks (i.e., rural areas, vessels, airplanes). Therefore, the NTN represents a coverage extension for the terrestrial network in a world market where the customer needs are changing radically. Indeed, the demand for different services is growing steadily due to the ever-increasing number of devices connected to the Internet.

Ericsson Mobility Report [6] predicts that at the end of 2024 the usage of smartphones will increase up to 45% by consuming more than 21 GB of data per month on average (about 4 times more than the amount consumed in 2018) and generating 95%

of the total mobile data traffic. In this context, satisfying all of the user requests and providing the desired QoS anytime and anywhere, even when traveling on cruises, high-speed trains, and airplanes, is one of the main challenges for future telecommunication systems.

Not limited to delivering service where it is economically challenging to provide coverage with a terrestrial network, 5G NTN ensures service continuity of Machine-to-Machine (M2M)/Internet of Things (IoT) devices or for people traveling on-board of moving platforms as well as service availability in both critical communications and emerging services (i.e., maritime, aeronautical, railway). Furthermore, 5G NTN is expected to become an efficient solution to enable network scalability owing to the provision of multicast/broadcast resources for the delivery of data to network edges and user terminals [3]. As a result, NTN promises benefits achieved by revolutionizing the traditional cellular network infrastructure owing to wide-area coverage, scalability, service continuity, and availability.

### 3.1.1 Motivation and Contributions

The motivation behind this work stems from the interest shown in satellite networks over the last decade by both industry and academia. It accentuates the added value for 5G networks and becomes essential for two main reasons. The first one is that a satellite connection becomes indispensable where there is no coverage, due to the impossibility of infrastructure (i.e., maritime scenarios), or where there would be a possibility but not the economic convenience. The second reason is related to the security and the resilience of communications, as well as to crisis management. Differently from the terrestrial communications that are potentially subject to service interruptions due to natural disasters or attacks, satellite networks guarantee service continuity in the cases of mission-critical applications, which cannot take the risk of failures.

In past literature, several works reviewed the satellite systems. Table 3.1 provides a comparison of the existing surveys on satellite communications. The main contributions of this survey are the following:

- review the NTN wireless system and summarize its main features as per the official 3GPP technical reports;
- discuss the state of the art on NTN along the evolutionary path of wireless communications (from First Generation (1G) to Fourth Generation (4G));
- understand the role of NTN within the 5G NR system;
- overview the current 3GPP activities to support NTN as part of the NR technology;
- identify open issues and address future research directions.

Table 3.1: Comparison of surveys on satellite communications.

<b>Year</b>	<b>Publication</b>	<b>Brief description</b>
2006	Chowdhury <i>et al.</i> [25]	The survey on handover schemes in satellite networks focuses on: classification of handover schemes; comparison of handover schemes according to certain criteria; considerations and future research directions on handover management in satellite networks.
2009	Chini <i>et al.</i> [26]	The survey on mobile satellite systems focuses on: network architectures, services, standardization, operational systems, and research issues; comparison of different mobile satellite systems.
2011	Arapoglou <i>et al.</i> [27]	The review on MIMO over satellite networks focuses on: MIMO-based techniques in terrestrial networks; MIMO over satellite, satellite channel characteristics, and future research directions.
2016	De Sanctis <i>et al.</i> [28]	The survey on satellite communications supporting IoRT focuses on: satellite-based IoT; MAC protocols for satellite routed sensor networks; efficient IPv6 support and heterogeneous network interoperability; QoS management and group-based communications.
2016	Radhakrishnan <i>et al.</i> [29]	The survey on inter-satellite communication for small satellite systems focuses on: research conducted by the small satellite community; design parameters for inter-satellite communications; solutions that enable operations in small satellite systems.

2016	Niephaus <i>et al.</i> [30]	The survey on the state-of-the-art of satellite and terrestrial network convergence focuses on: scenarios, technical challenges, and related works concerning the convergence of satellite and terrestrial networks; functionality to optimize the traffic distribution; architectures and related adaptations to support the converged satellite and terrestrial networks.
2017	Kaushal <i>et al.</i> [31]	The survey on optical communications focuses on: challenges related to the performance of optical communications in integrated space-ground networks; techniques to mitigate the side effects of the atmosphere.
2018	Liu <i>et al.</i> [9]	The survey on space-air-ground integrated networks focuses on: state-of-the-art in either space or air networks; work on both space-ground networks and integrated space-air-ground segments; network design, resource allocation, open challenges, and future directions in integrated space-air-ground communications.
2019	Burleigh <i>et al.</i> [32]	The survey on small satellite communications and networks focuses on: current evolution of small satellites; scenarios, applications, advances, and developments in small satellites; aspects, perspectives, and open challenges of small satellite communications.
2020	Li <i>et al.</i> [33]	The survey on physical-layer security in space information networks focuses on: IoST systems and related challenges; satellite channel models and secrecy metrics; research activities on physical security and possible future studies.

<b>Our contributions</b>	This chapter surveys the NTN systems by focusing on: NTN uses cases and architectures; satellite network roadmap and role of NTN in cellular communications; 3GPP research activities, NTN open issues, and future research directions beyond 5G.
--------------------------	---

The remainder of this chapter is organized as follows.

- Section 3.2 provides a general description of the NTN and its use cases. In particular, subsection 3.2.1 introduces two platform classifications (i.e., spaceborne and airborne, which are characterized by different altitude range, orbit type, and beam footprint size) and the main NTN access components (i.e., NTN terminal, NTN gateway, service link, and feeder link). In subsection 3.2.2, the key NTN use cases are listed on the basis of the demanded service type; furthermore, a maritime scenario is illustrated as one of the most important NTN options.
- Section 3.3 describes the NTN architectural aspects. In more detail, subsection 3.3.1 demonstrates the satellite access architectures where the NTN terminal is served directly by the NTN platform. Alternatively, the NTN terminal and the NTN platform communicate through a relay node in relay-like architectures as highlighted in subsection 3.3.2. In subsection 3.3.3, several alternatives of how the NTN-based NG-RAN can be integrated with the terrestrial NG-RAN are discussed.
- Section 3.4 overviews the role of NTN in cellular communications up to 4G. Specifically, the roadmap of satellite systems is reviewed from the birth of the satellite networks independently from the terrestrial systems and their relation with the Second Generation (2G) technology in subsection 3.4.1, the integration of satellite networks with the Third Generation (3G) terrestrial system in subsection 3.4.2, and the growing interest in 4G satellite communication to deliver global connectivity in subsection 3.4.3.
- Section 3.5 outlines the vision of NTN from the 5G perspective (i.e., the introduction of software-defined networking and virtualization, network slicing, and edge computing) and summarizes the existing literature concerning security, cognition, Non-Orthogonal Multiple Access (NOMA), mobility, Internet of Space Things (IoST), and CubeSats.
- Section 3.6 reviews the current research activities conducted by 3GPP by enumerating the NTN features across the study items and highlights the associated 3GPP technical specifications and reports.

- Section 3.7 emphasizes the open issues with respect to mobility management, propagation delay, and radio spectrum. Future research directions are also discussed.
- Section 3.8 projects the perspectives of satellite communications onto the 6G wireless technology, which may offer extreme flexibility of integrated TN-NTN systems.
- Section 3.9 draws the essential conclusions.

## 3.2 NTN Characteristics and Applications

### 3.2.1 NTN General Description

An NTN may have different deployment options according to the type of the NTN platform involved, as listed in Table 3.2.

**Table 3.2.** Types of NTN Platforms [2].

Platforms	Altitude Range	Orbit	Beam Footprint Size
GEO satellite	35786 km	Fixed position in terms of elevation/azimuth w.r.t. a given point on Earth	200 - 3500 km
MEO satellite	7000 - 25000 km	Circular around Earth	100 - 1000 km
LEO satellite	300 - 1500 km	Circular around Earth	100 - 1000 km
UAS platform	8 - 50 km (20 km for HAPS)	Fixed position in terms of elevation/azimuth w.r.t. a given point on Earth	5 - 200 km

The NTN platforms are grouped into two main categories: spaceborne and airborne. The classification of *spaceborne* platforms typically depends on three main parameters, such as altitude, beam footprint<sup>1</sup> size, and orbit.

Spaceborne platforms can be differentiated as:

- *Geostationary Earth Orbit (GEO)* has a circular and equatorial orbit around Earth at 35786 km altitude and the orbital period is equal to the Earth rotation period. The GEO appears fixed in the sky to the ground observers. GEO beam footprint size ranges from 200 to 3500 km.

<sup>1</sup> The beam footprint [3] has an elliptical shape and it may be either moving over Earth with the NTN platform on its orbit or remain Earth-fixed if beam pointing mechanisms are applied to compensate for the NTN platform motion.

- *Medium Earth Orbit (MEO)* has a circular orbit around Earth, at an altitude varying from 7000 to 25000 km. MEO beam footprint size ranges from 100 to 1000 km.
- *Low Earth Orbit (LEO)* has a circular orbit around Earth, at an altitude between 300 to 1500 km. LEO beam footprint size ranges from 100 to 1000 km.

LEO and MEO are also known as Non-Geostationary Orbit (NGSO) satellites for their motion around Earth with a lower period than the Earth rotation time; in fact, it varies from 1.5 to 10 hours.

The *airborne* category encompasses Unmanned Aircraft Systems (UAS) platforms, which are typically placed at an altitude between 8 and 50 km and include High Altitude Platform System (HAPS) at 20 km altitude. Similar to the GEO satellite, the UAS position can be kept fixed in the sky w.r.t. a given point on the ground. UAS beam footprint size ranges from 5 to 200 km.

Spaceborne and airborne platforms may belong to two different configurations distinguished according to the carried payload. Indeed, NTN platforms implement either transparent or regenerative payload. The *transparent* or bent-pipe payload configuration foresees that only radio frequency filtering, frequency conversion, and amplification are done on-board the satellite (or UAS platform). Conversely, in the *regenerative* payload configuration, the NTN platform effectively implements all the gNB functions on board. A detailed description of the NTN architectures is provided in Section 3.3.

In addition to space/airborne platforms, the NTN access is featured by the following components:

- *NTN terminal* refers to either the 3GPP UE or a specific satellite terminal. Very small aperture terminals operate in the radio frequency of Ka-band (i.e., 30 GHz in the uplink and 20 GHz in the downlink), whereas handheld terminals operate in the radio frequency of S-band (i.e., 2 GHz).
- *NTN gateway* is a logical node connecting the NTN platform with the 5G core network.
- *Service link* is the radio link between the NTN terminal and the NTN platform.
- *Feeder link* is the radio link between the NTN gateway and the NTN platform.

### 3.2.2 5G NTN Use Cases

The NTNs are expected to play an important role in 5G & beyond systems by covering different verticals, including transport, eHealth, energy, automotive, public safety, and

many others (see Fig. 3.1). 5G NTN use cases may be divided into three categories: *service continuity* to provide NTN access where this is infeasible through terrestrial networks; *service ubiquity* to improve the NTN availability in cases of disasters that lead to a temporary outage or destruction of a terrestrial network; and *service scalability* to offload traffic from the terrestrial networks, also during the busy hours [34].

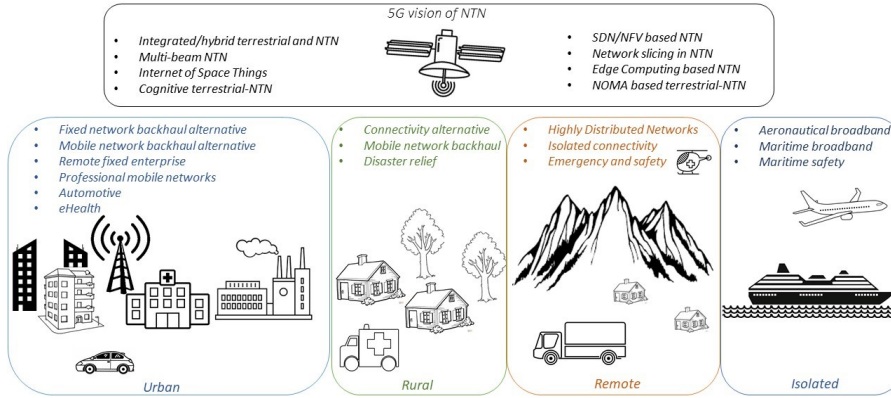

**Fig. 3.1.** 5G NTN use cases.

In the 5G & beyond context, the NTN supports all three usage scenarios defined by the ITU [5], which are eMBB, mMTC, and URLLC. Since providing URLLC services may be a challenging task due to the satellite propagation delays and stringent URLLC requirements of reliability, availability, and latency, NTN mainly considers the eMBB and mMTC as the main 5G service enablers for the definition of the use cases [3].

As for eMBB services, NTN aims to provide broadband connectivity in un/under-served areas and on moving platforms (i.e., vessels and aircrafts), as well as to offer network resilience by combining terrestrial and NTN systems. Furthermore, NTN is also exploited to offload the terrestrial networks by making a broadcast channel available to deliver broadcast/multicast contents or wide/local area public safety messages to handheld or vehicle-mounted UEs across home premises or on-board of moving platforms.

As for mMTC, NTN supports connectivity for both wide and local area IoT services. In the case of a wide-area IoT service, the connectivity between the IoT devices and the NTN platform is provided, as well as the service continuity, through satellites and terrestrial gNBs for telematics applications (i.e., automotive and road transport, energy, agriculture). In the case of a local area IoT service, NTN provides connectivity between the mobile core network and the gNBs serving IoT devices by gathering

information belonging to the groups of sensors deployed under the coverage of one or more cells.

Therefore, the NTN is relevant for 5G NR systems because it aims to offer benefits over urban and rural areas in terms of the 5G targeted performance (i.e., experienced data rate and reliability), as well as to provide connectivity in un-/under-served areas for both users and mMTC devices.

Among the key use cases, NTN also represents an attractive solution for the *maritime scenario* [35]. Ensuring in-sea coverage is infeasible via a terrestrial network because it is expensive and introduces capacity limits. Hence, NTN may be useful to facilitate communications within the maritime industry by managing the maritime space and providing seamless sea traffic services to devices and users in collaboration with seaborne platforms. NTN may also be exploited for sending notifications (i.e., to inform vessels of the location of a vessel in danger) and emergency requests (i.e., maritime accidents) to improve maritime safety [36].

### 3.3 NTN Architectures

In NG-RAN, new interfaces and protocols are being added to support NTNs. An NTN platform may act as a space mirror or gNB in the sky. Consequently, two satellite-based NG-RAN architectures are possible: *transparent* and *regenerative*. In the latter case, the NTN platform may implement partial or full gNB functionality depending on whether the gNB functional split (i.e., the gNB comprises central and distributed units [37]) is considered or not.

Another classification of the NTN architectures can be made based on the type of access [2]. Hence, in the *satellite access architecture* the NTN terminal is directly served by the NTN platform, whereas in the *relay-like architecture* the NTN terminal and the NTN platform communicate with each other via a relay node.

#### 3.3.1 Satellite Access Architectures

Fig. 3.2(a) displays the transparent satellite-based architecture where the NTN platform relays the NR signal from the NTN gateway to the NTN terminal and vice versa. The Satellite Radio Interface (SRI) on the feeder link is the same as the radio interface on the service link (i.e., NR-Uu). The NTN gateway can forward the NR signal of the NR-Uu interface to the gNB. One or more transparent satellites may be connected to the same gNB on the ground.

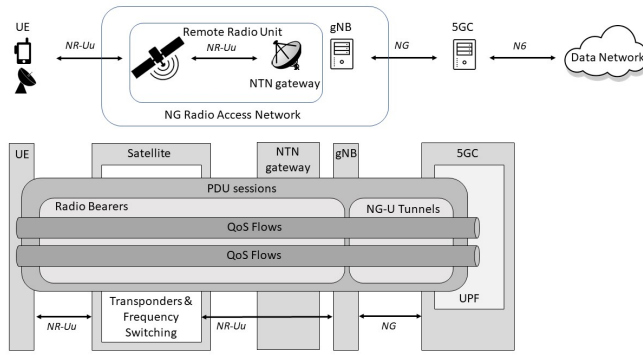

(a) Transparent payload-based satellite

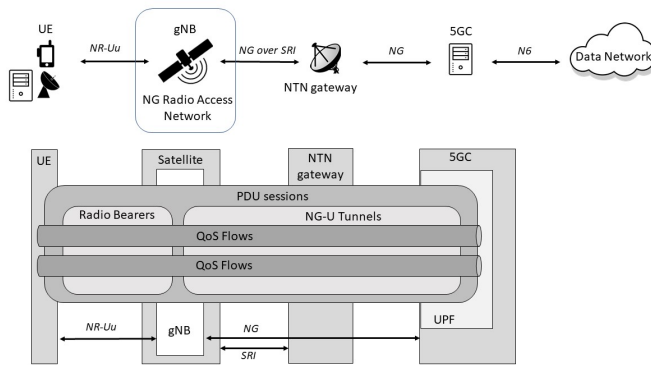

(b) Regenerative payload-based satellite

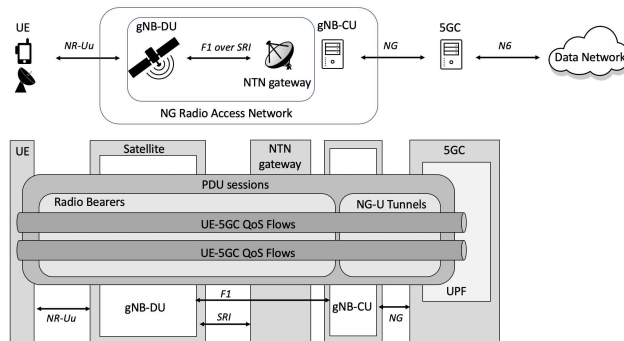

(c) Regenerative satellite-based gNB-DU

**Fig. 3.2.** Satellite access architectures.

Fig. 3.2(b) demonstrates the regenerative satellite-based architecture where the NTN platform has on-board processing capabilities to generate/receive the NR signal to/from the NTN terminal. The NR-Uu interface is on the service link between the NTN terminal and the NTN platform. The radio interface between the NTN platform and the 5GC is NG, which is over SRI in the air path between the NTN platform and the NTN-gateway. Inter-Satellite Link (ISL)s are transport links between the NTN platforms.

As specified in the NG-RAN [37] architecture description, a gNB consists of a gNB central unit (gNB-CU) and one or more gNB distributed units (gNB-DU). Fig. 3.2(c) shows a “5G NR friendly” NTN architecture based on the regenerative satellite. The gNB-CU on the ground is connected via the F1 interface over SRI to the NTN platform, which acts as a gNB-DU. The NR-Uu is the radio interface between the NTN terminal and the gNB-DU on-board satellite, whereas the NG interface connects the gNB-CU on the ground to the 5GC. gNB-DU on-board different NTN platforms may be connected to the same gNB-CU on the ground.

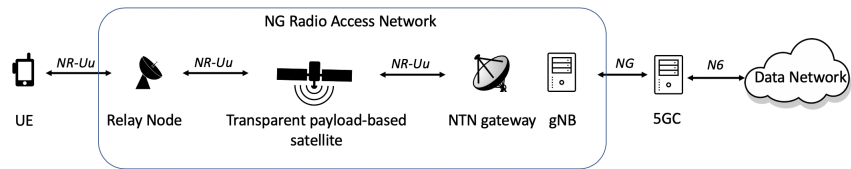

(a) Transparent payload-based satellite

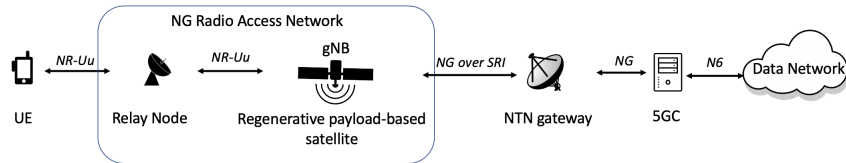

(b) Regenerative payload-based satellite

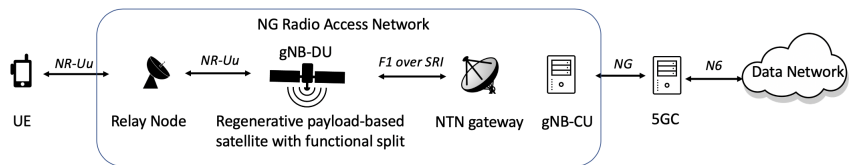

(c) Regenerative satellite-based gNB-DU

**Fig. 3.3.** Relay-like architectures.

### 3.3.2 Relay-like Architectures

In Fig. 3.3(a), the access network forwards the NR signal to the NTN terminal through a relay node, which receives it from the transparent payload-based satellite. In Fig. 3.3(b) and Fig. 3.3(c), the regenerative payload-based satellite includes full and part of the gNB, respectively. The relay node forwards the NR signal received from the regenerative payload-based satellite (see Fig. 3.3(b)) with the gNB functional split (see Fig. 3.3(c)), to the NTN terminal. For further study, Integrated Access and Backhaul (IAB) architectures are described in [38], which relay the access traffic when both access and backhaul links are considered.

### 3.3.3 Service Continuity & Multi-Connectivity

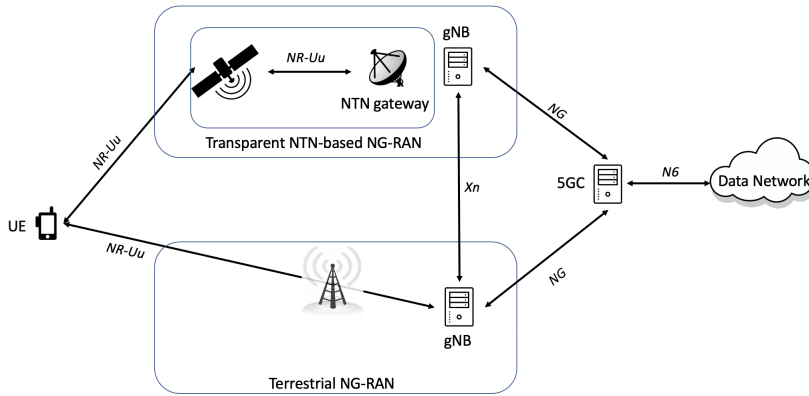

(a) A transparent NTN-based NG-RAN and a terrestrial NG-RAN

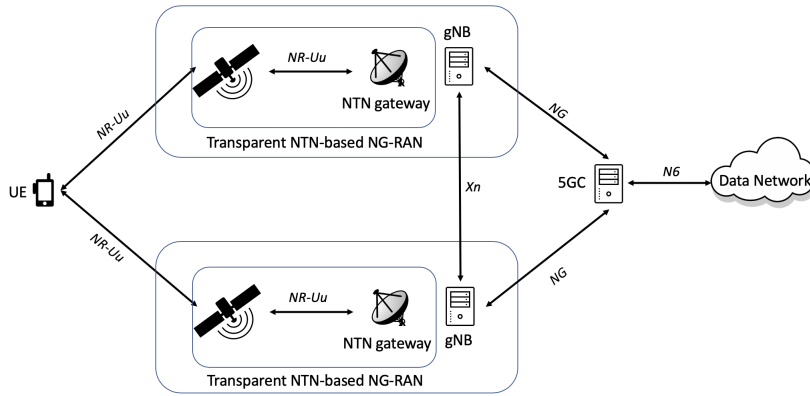

(b) Two transparent NTN-based RANs

**Fig. 3.4.** Architectures supporting multi-connectivity and involving transparent payload-based satellite.

The integration of NTNs and terrestrial networks is essential to guarantee service continuity and scalability in 5G and beyond systems. An integrated TN-NTN system may offer benefits in urban and rural areas in terms of the 5G performance targets (i.e., experienced data rate and reliability), guarantee connectivity among dense crowds (such as concerts, stadiums, city centers, and shopping malls) and for users traveling in high-speed trains, in airplanes, and on-board of cruises.

However, 5G systems support service continuity not only between terrestrial NG-RAN and NTN NG-RAN, but also between two NTN NG-RANs. 3GPP TR 38.821 [2] studies the feature of multi-connectivity to allow simultaneous access to both the NTN and terrestrial NG-RANs or two NTN NG-RANs. Therefore, the architectures supporting multi-connectivity are described below.

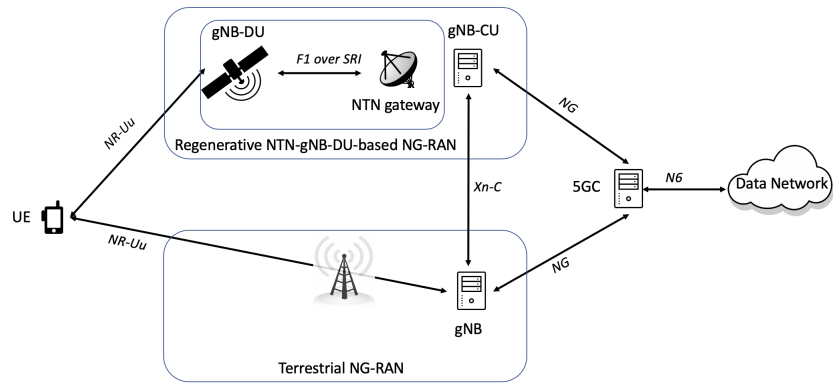

(a) A regenerative NTN-gNB-DU-based NG-RAN and a terrestrial NG-RAN

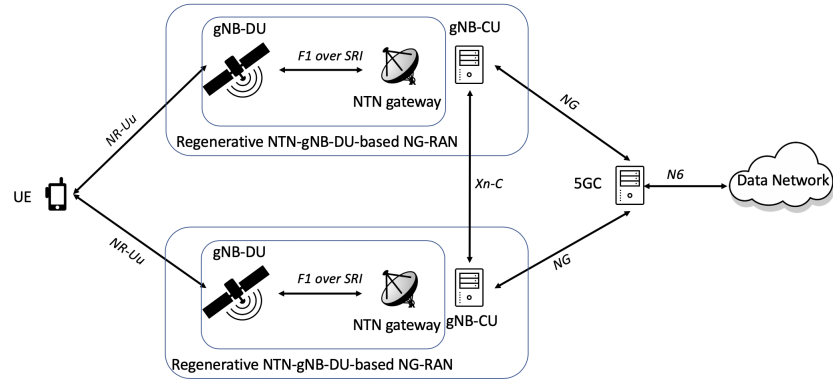

(b) Two regenerative NTN-gNB-DU-based RANs

**Fig. 3.5.** Architectures supporting multi-connectivity and involving regenerative payload-based satellite as distributed unit.

In Fig. 3.4(a), the ground terminal is connected simultaneously to the 5GC via both transparent NTN-based NG-RAN and terrestrial NG-RAN. The NTN gateway is located in the Public Land Mobile Network (PLMN) area of the terrestrial NG-RAN.

Fig. 3.4(b) refers to the combination of two transparent NTN-based NG-RANs consisting of either GEO or LEO, or a combination of both. This scenario may be followed to provide services to the UEs in un-served areas. In particular, LEO is employed to deliver delay-sensitive traffic since it is being characterized by lower propagation delay than GEO. The latter is used to provide additional bandwidth and, consequently, higher throughput. Fig. 3.5(a) demonstrates the combination of a regenerative NTN-gNB-DU-based NG-RAN and a terrestrial NG-RAN. The functional split is applied in this type of architecture; hence, the NTN platform represents a distributed unit of the gNB and the related central unit is on the ground. This scenario may be followed to provide services to the UEs in under-served areas. Multi-connectivity can also involve two regenerative NTN-gNB-DU-based NG-RANs (see Fig. 3.5(b)).

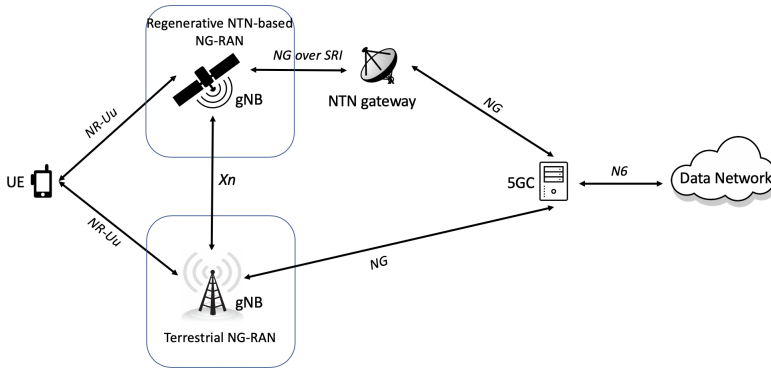

(a) A regenerative NTN-based NG-RAN and a terrestrial NG-RAN

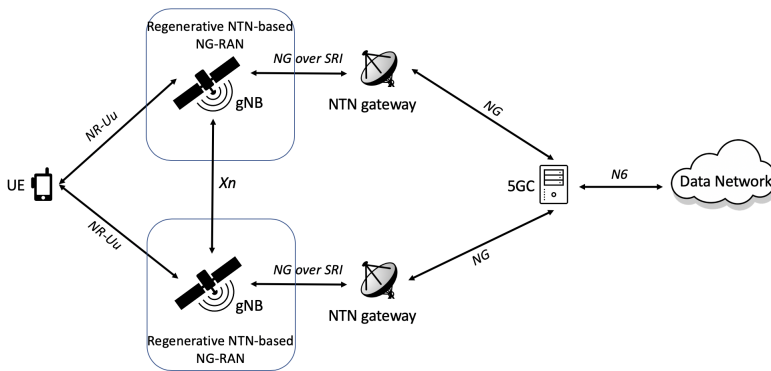

(b) Two regenerative NTN-based RANs

**Fig. 3.6.** Architectures supporting multi-connectivity and involving regenerative payload-based satellite.

Fig. 3.6(b) considers the combination of two regenerative NTN-based NG-RANs consisting of either GEO or LEO, or a combination of them both being interconnected with ISLs. Differently from the previous case, in this type of the architecture, the NTN platform performs all the gNB tasks (i.e., the functional split is not applied). Multi-connectivity can also involve regenerative NTN-based NG-RAN and terrestrial NG-RAN (see Fig. 3.6(a)).

## 3.4 Role of Non-Terrestrial Networks in Cellular Communications

### 3.4.1 Satellite Network Roadmap

Satellite networks were born independently from terrestrial systems because of the different nature of satellite communications in terms of the covered distances, utilized radio spectrum, design, costs, applications, and targets. Satellite systems were initially intended to provide 1G analog services, such as in voice and other low data rate applications, primarily in maritime scenarios (i.e., INMARSAT).

In the early '90s with the 2G technology, satellite communications were exploited to deliver aeronautical services to people traveling on aircrafts as well as to provide coverage in certain land areas. Meanwhile, NGSO satellite constellations (e.g., Iridium and Globalstar) gained the attention of the research community due to their ability to provide global satellite coverage. However, it was found to be expensive to compete with GEO and cellular networks.

Further, the so-called Super GEO satellites succeeded above all in niche areas (sea and aeronautics) where a terrestrial network is expensive to deploy [39], whereas *little, big, and super* LEO satellites with their key issues (i.e., spectrum allocation and regulatory aspects) are considered to be a part of the satellite personal communication networks [40].

As satellites are typically proprietary solutions, the integration between satellite and terrestrial networks is difficult. However, several aspects (i.e., higher costs, limited coverage, and weak exploitation of satellite features) inspired the thinking to combine satellite and cellular networks first by supporting Global System for Mobile Communications (GSM) [41] via satellite through GEO Mobile Radio (GMR) air interface. Then, an integration of satellites with terrestrial networks aimed to support the emerging Third Generation (3G) wireless system, also known as Universal Mobile Telecommunications System (UMTS) [42].

### 3.4.2 Satellites in 3G UMTS Systems

Satellite network operators decided to collaborate rather than compete with cellular network operators. Hence, new features (i.e., location update, handover) were added to the UMTS specification to render the satellite air interface fully compatible with the terrestrial UMTS networks. This fostered the commercial roll-outs of the 3G technology owing to the rapid delivery of UMTS services through the satellites.

UMTS represented the first step toward the convergence of mobile and broadband systems by offering services to groups of users (i.e., Multimedia Broadcast Multicast Service (MBMS) [43]). Indeed, the 3G UMTS technology is characterized by the need to provide MBMS services to the users located inside and outside the terrestrial coverage via the 3G cellular network or Satellite-Digital Multimedia Broadcasting (S-DMB) [26]. Therefore, ITU initiated the IMT-2000 standardization framework and defined the UMTS technology as a 3G global wireless system operating in the frequency band of 2 GHz. Further on, the satellite system was considered complementary to the terrestrial network in providing services for international roaming as well as in serving sparsely populated areas to reach ubiquitous coverage [44].

Several EU activities [45], such as INSURED, NEWTEST, SECOMS, SINUS, and TOMAS, were directed to study the air interface, mobile terminals, and applications of the satellite component in UMTS (Satellite UMTS (S-UMTS)). Researchers were hence driven to propose the integration of terrestrial and satellite networks for a more efficient 3G system. For example, in [46], technologies such as Intelligent Network [47], Mobile-IP [48], and dual-mode mobile terminals have been at the foundation of a possible S-UMTS architecture. Further, the ever-increasing demand for group-oriented services by the UEs on-board of vehicles, aircrafts, ships, and trains led to new network solutions for MBMS delivery via satellite.

In [49], a new integrated Satellite-Terrestrial UMTS (S/T-UMTS)) architecture has been considered for the extension of cellular network coverage, to provision urban and indoor coverage with the introduction of the Intermediate Module Repeater (IMR). This allowed for tight cooperation between satellite and terrestrial network operators in providing low-cost MBMS services. A RRM strategy has been proposed to support both data streaming and push & store services by accounting for the QoS and Grade of Service (GoS) [49]. An RRM scheme for the delivery of MBMS services has also been discussed in [50] by considering satellite system requirements. Another RRM technique has been studied in [51] where an RRM analysis has been conducted for a Dynamic Channel Allocation (DCA) technique with Queuing oh Handover (QH) requests by exploiting a grid for traffic prediction and by considering a realistic mobility model.

With the integration of satellites into the 3G terrestrial networks, user terminals were designed to operate in dual-mode to enable service continuity from one network to another (i.e., inter-segment handover) whenever necessary. For example, the SINUS project aimed at designing an inter-segment handover algorithm, which has been described in [52]. In [53], a new vertical handoff decision algorithm has been designed for integrated UMTS and LEO satellite networks by taking into account the performance in terms of QoS and handover costs. When a handover takes place between the LEOs of a constellation, it can belong to either of the three categories: (i) spot-beam handover occurring between the neighboring spot-beams of a satellite, (ii) satellite handover that features the transfer of an existing connection from one satellite to another, and (iii) ISL handover where ISL links are exploited to reroute the connection when inter-plane ISLs – connecting the satellites located at different orbital heights – are switched off temporarily. In [25], handover schemes for LEO satellite networks have been reviewed.

Since the satellite system was first considered as an integral part of the 3G wireless network, there were many technological and physical aspects (i.e., propagation delay, Doppler effect, satellite diversity) to be investigated for efficient satellite-terrestrial interworking. In [54], the Satellite Wide-band Code Division Multiplexing Access (SW-CDMA) air interface – driven by the European Space Agency (ESA) to integrate satellites into the 3G UMTS global network by minimizing the difference with the Wide-band Code Division Multiplexing Access (WCDMA) air interface [55] – has been deeply analyzed in terms of the physical-layer performance and the LEO-constellation system capacity has been evaluated. Channel variations due to the environment (i.e., Rice factor) have been taken into consideration in [56] to propose a novel adaptive modulation and coding technique, which better accommodates mobile satellite communication systems.

Over the UMTS time, HAPS [57] started representing a valid alternative to satellites for the introduced advantages, such as rapid deployment, broad coverage, low upgrade cost, high flexibility, and low propagation delay. In fact, they were considered quasi-stationary as well as taller than a cellular antenna and lower than a satellite. In [58], a feasibility study has been carried out to integrate HAPS with the terrestrial UMTS system by analyzing the impact in terms of interference. Further, requirements for full compatibility with the UMTS specifications have been studied. Moreover, mindful of the importance of HAPS in supporting the MBMS service over 3G and beyond systems, HAPS capabilities and limitations have been investigated in [59].

Therefore, satellites saw steady development in terms of the supported functionalities. Initially, satellites had a basic feature to relay or forward signals and carry

transparent-based (or bent-pipe) payload. Over time, they progressed to feature on-board processing or regenerative-based payload, while the NGSO satellite constellations inter-connected through ISLs were revised with an emphasis on the design costs reduction as compared to the first NGSO satellites – to achieve lower propagation delays than with GEO satellites.

### 3.4.3 Satellites in 4G Systems

The Long-Term Evolution (LTE) system [60] was designed to support IP-based traffic as well as to achieve lower latency, higher data rate, and better spectrum efficiency than UMTS. The 4G technology represents a convergence of different access networks (i.e., cellular and satellite networks) and supports global roaming as one of its main targets. Since the terrestrial network infrastructure may be occasionally infeasible (i.e., economically, due to impossibility of installation) across many scenarios (i.e., maritime, aeronautical, disaster relief, military, and others), the satellite technology gained considerable attention of researchers in the 4G era.

The Mobile Satellite System (MSS) [26] provided satellite communication services to mobile users and represented an attractive way to provide coverage at lower costs in places that are not (well) reachable by the cellular network. Differently from the Fixed Satellite System (FSS) being affected by atmospheric attenuation, MSS suffers from non-Line of Sight (LoS) propagation attenuation, known as multipath propagation, due to obstacles (e.g., buildings, trees) and to their irregularities (e.g., foliage).

The integration of satellite and terrestrial access technologies can help overcome the non-LoS degradation through either *integrated networks* or *hybrid networks*. The integrated approach foresees that the terrestrial network can be considered as an alternative communication system to the satellite network. In [61], a layered approach for integrating the satellite and the terrestrial networks has been assessed in terms of services, radio access technologies, and protocol layers. Unlike in [61], where a multi-layered architecture has been proposed to enable satellite communications over various layers (i.e., HAPS, LEO, MEO, GEO) through inter- or intra- satellite links, in [62] an ultra-dense configuration of only LEO satellites has been integrated with the terrestrial network and an optimization model has been proposed to offload the terrestrial data traffic for maximizing the LEO-based backhaul capacity.

The hybrid network adopts terrestrial gap fillers for re-transmitting the satellite signal in non-LoS conditions, supplies the return link (from the terminal to the satellite) with the terrestrial system, and extends the satellite coverage in indoor or urban areas with local eNB and vice versa. In [63], a hybrid satellite-terrestrial

network architecture has been proposed for broadcast and two-way missions. For the former, satellite and terrestrial relays operate in Single-Frequency mode. For the latter, satellite and terrestrial eNBs manage the spectrum so as to reduce interference between the satellite beams and the terrestrial network cells.

Further, communication in rural and scattered suburban areas is handled by the satellite segment, whereas in urban and dense suburban scenarios transmissions are handled by the ground component. The satellite is connected to the 4G core network through a gateway, which is able to handle its integration into a hybrid network. Conversely, the ground component is composed of terrestrial relays to forward the traffic to the terminal and the eNBs that manage the two-way communication and the return link.

The 4G terrestrial network can take advantage of cooperative communication between the users (i.e., Device-to-Device (D2D) communication) to improve the QoS of edge nodes and to favor the out-of-coverage communication. Cooperation among the devices is also exploited in 4G satellite networks, thus raising several issues, such as synchronization, bandwidth allocation, and selection of forwarding and relaying devices [64]. In [65], two cooperation schemes, namely, Decode-Forward and Amplify-Forward, have been analyzed with the aim to determine, which solution can offer better data forwarding capabilities from the satellite to the mobile terminal, even when the latter moves into the areas that are unreachable from the satellite.

Further, 4G technology fuels the ever-increasing demand for real-time video services and, consequently, raises issues of link adaptation and radio resource management. Among the link adaptation procedures, Adaptive Modulation and Coding (AMC) has the aim to select the Modulation and Coding Scheme (MCS) on the basis of the channel conditions of a single user or a group of users (i.e., multicast).

In the case of a multicast scenario, manifold AMC solutions can be implemented. The conservative approach, named Conservative Multicast Scheme (CMS), adapts the MCS of the entire user set according to the lowest channel quality experienced in the multicast group (i.e., the most robust modulation). The opportunistic approach, named Opportunistic Multicast Scheme (OMS), serves only a set of users in a given TTI to maximize the overall throughput. Another approach is known as Subgrouping: it splits the multicast group into smaller subgroups with the aim of optimizing a given objective function (i.e., user satisfaction or system Aggregate Data Rate). In [66], a novel radio resource allocation scheme combined the Multicast Subgrouping [67] with the Application-Layer Joint Coding (ALJC) technique [68] to enhance the performance of the multicast transmissions over satellite evolved MBMS (eMBMS) networks.

Radio spectrum management issues become essential not only due to the increased demand for eMBMS [69] but also due to the satellite architecture features that progress from single-beam to multi-beam. Multi-Spot Beam Satellites are based on the frequency re-use principle, which is well-known for terrestrial communications. According to the frequency re-use factor, the available spectrum is split such that the adjacent spot-beams do not utilize the same set of radio resources to avoid inter-beam interference.

In [70], a dynamic bandwidth allocation technique has been proposed to reduce the difference between the available system capacity of all spot-beams and the total traffic demand as well as achieve fairness among spot-beams with different traffic demands. In [71], the authors have proposed a radio resource allocation scheme for an integrated satellite/terrestrial system with the aim to optimize the spectral efficiency, increase the system capacity, and minimize the interference between the terrestrial and the satellite components, since terrestrial multi-cells re-use satellite resources.

In [72] and [73], two mathematical frameworks have been developed to handle the problem of inter-beam and inter-satellite interference in multi-beam satellite systems. In [72], a mathematical study of an advanced precoding scheme has been completed by taking into account the information about the route and the distribution of users as well as their CSI. In [73], the precoding task has been solved as a  $k$ -means-based clustering problem.

The integration of different radio access networks (i.e., satellite and terrestrial) to achieve global connectivity poses several challenges due to the heterogeneity in access technologies, network architectures, and protocols as well as the demand for dissimilar types of services [74]. Not limited to radio resource management, one of the key issues is mobility and, hence, handover procedures. Handover may belong to *intra-* or *inter-system* types. The former may occur either between the beams generated by the same satellite (i.e., intra-satellite handover) or between two satellites (i.e., inter-satellite handover). The latter may occur between the satellite radio access network and the terrestrial system and vice versa (i.e., vertical handover).

From past literature, it follows that inter-system handover has attracted much interest in the research community. In [75], a handover procedure subdivided into initialization and execution phases has been analyzed for integrated satellite-terrestrial mobile systems, and then a mathematical model has been presented for assessing inter-system handover. In [76], a buffering scheme has been proposed prior to handover to compensate for service interruptions during inter-system handover, whereas in [77], protocols for mobility management have been designed to select the best network in

the case of inter-system handover according to certain decision metrics (i.e., costs, network conditions, power consumption, system performance, and user activity).

### 3.5 Non-Terrestrial Networks in 5G Systems

Until a couple of decades ago, the satellite and terrestrial networks were considered to be independent and were developing separately from each other. From the current-generation wireless technology (i.e., 5G) onward, these two networks are viewed from a different perspective. The 3GPP standardization has already completed the first 5G NR specifications and progressed on solutions to support the NTN in 5G NR systems [78]. In addition, several projects like ESA SATIS5 [79] and SAT5G [80], which is part of the H2020 5G Infrastructure Public Private Partnership (5G PPP) initiative [81], targeted to propose cost-effective solutions to provide 5G connectivity everywhere and to create new opportunities in the 5G world market.

Service continuity is one of the key requirements to be ensured when the 5G NTN NG-RAN is integrated with the 5G NR terrestrial RAN or with another 5G NTN NG-RAN [2]. The requirement of service continuity between the two NG-RANs means that the specification support should enable a seamless handover between the systems without a service interruption as well as a fluent IDLE mode UE operation for optimal network selection.

The NTN segment, when combined with the terrestrial network, plays an essential role to achieve global coverage owing to boosting capacity (as a result of high-frequency reuse and precoding techniques) and ensuring service continuity even when traveling.<sup>2</sup> In [82], architectural and technical issues have been discussed for 5G systems including the NTN, whereas in [83] the effect of NTN integration into the mobile systems has been assessed through an experimental comparison in terms of KPIs.

The integration of terrestrial and non-terrestrial networks is thus considered to be an attractive solution for 5G technology development. In the past couple of years, multiple research works have investigated a combination of two radio access networks. The authors in [9] were the first to provide a review on Space-Air-Ground Integrated Network (SAGIN), where the system performance has been improved by exploiting deep learning methods for traffic balancing purposes [84].

<sup>2</sup> It is worth noting that satellite links are reliable only in outdoor conditions. In indoor conditions, the satellite access network is not used directly by the devices due to higher pathloss and, therefore, the satellite signal needs to be amplified by mounting terminals on-board aircrafts/vessels/trains. Indoor conditions are considered only for HAPS, since they are closer to Earth and, hence, the pathloss is lower than in the satellite networks [3].

**Table 3.3.** Classification of research work by common topics for different wireless technologies.

Topic	Motivation		
	3G – UMTS	4G – LTE	5G – NR
Integrated NTN-Terrestrial Networks	Integration of satellites with terrestrial networks is indispensable to reach ubiquitous coverage. The idea of a global wireless system was born during the 3G times and characterized all subsequent wireless technologies up to the present day. Therefore, researchers considered it as an attractive research topic.		
	[49], [58], [59]	[61], [62], [63]	[82], [83], [9], [85]
Radio Resource Management	RRM is relevant to offer tight cooperation between satellite and terrestrial networks. Researchers focused on devising efficient radio resource allocation methods to reduce all interference types as well as on proposing effective link adaptation procedures to provide real-time video services.		
	[50], [51], [56]	[66], [67], [70], [71], [72], [73]	[86], [87], [88]
Mobility Management	Mobility management is essential to offer service continuity by achieving seamless handover over heterogeneous wireless access networks. Hence, researchers investigated new procedures for rapid inter-system handover to avoid service interruptions and optimize network selection.		
	[52], [53], [25]	[74], [75], [76], [77]	[89], [90], [91]

In [92], a new perspective on integrated systems has been presented by discussing Software-Defined Space-Terrestrial Integrated Networks based on Software Defined Networking (SDN) [93], which separates the control plane from the data plane. In [94], the integration of non-terrestrial and terrestrial networks has been simplified by introducing a new architecture that combines SDN and Network Function Virtualization (NFV) [95], which implements specific hardware functionalities via software. Security is one of the essential concerns in NTN communications. Several works in the literature tackled this issue in integrated TN-NTN networks, wherein cognitive radio is introduced to improve the spectrum utilization when the NTN and the cellular network share the same bandwidth. The authors in [96] investigated the physical layer security and proposed a stochastic beamforming approach. Multi-antenna terrestrial base stations were employed as a source of green interference to enhance the security of NTN communications in [97], [98], and [99].

In [100], a cooperative secure transmission beamforming scheme has been designed to assess the communications security in TN-NTN systems and the secrecy rate has been maximized under the power and transmission quality constraints. In [101], the secrecy performance has been analyzed while considering the connectivity in a multi-antenna NTN with terrestrial recipients (i.e., downlink direction) via multiple cooperative relays and in the presence of several eavesdroppers. In [102], different adaptive transmission schemes have been addressed to analytically obtain the expression for the achievable channel capacity in hybrid TN-NTN relay networks.

A joint opportunistic relay selection scheme has been proposed in [103] to enhance the system protection against attacks. Three typical attack approaches have been described in [104] to illustrate possible threats to the NTN security. Unlike previous works where cooperation has been adopted for cognitive TN-NTN networks, in [105] a non-cooperative game with limited information exchange was constructed to address the power control problem in the case of spectrum sharing between the NTN and the terrestrial network.

Further, the performance of cognitive TN-NTN systems has been investigated in [106] via the outage analysis given the interference temperature constraints and in [107] by analytically deriving the outage probability and the ergodic capacity. This latter parameter has also been formulated in [108], where different full cooperative relay protocols (i.e., amplify-forward and decode-forward) were considered, whereas in [109] the system performance has been assessed through a partial relay selection scheme.

The 5G wireless technology features NOMA among its radio access techniques. Unlike the traditional Orthogonal Multiple Access (OMA) techniques where one user is being served on each orthogonal carrier, NOMA enables more than one user to be served on each orthogonal carrier [110]. In the literature, several works investigated both the NTN and the integrated TN-NTN networks based on NOMA techniques. A survey on multi-satellite cooperative transmission systems has been offered in [111], where multi-satellite relay transmission systems based on NOMA have also been addressed.

In [112], the achievable ergodic capacity has been formulated for a NOMA-uplink NTN, whereas in [113] both the ergodic capacity and the outage probability have been investigated for a hybrid TN-NTN relay network with the cooperative NOMA scheme in the downlink direction. Also in [114], the authors analyzed the outage probability and derived it in the closed form. Since terrestrial and NTN systems interfere while the two downlink channels reuse the same bandwidth, the respective capacity has been computed for a NOMA-based TN-NTN system in [115], whereas an optimization design has been proposed in [116] for NTN multicast communications that share the mm-Wave spectrum with terrestrial communications by exploiting the NOMA techniques.

Table 3.4: Summary of past works on NTN by open research topics in 5G & beyond.

<b>Topic</b>	<b>Description</b>
<b>Cognitive Radio</b>	Cognitive radio is an enabling technology for 5G & beyond communications. Researchers focused on new cognitive radio techniques to handle massive access to the NTN and spectrum sharing in integrated TN-NTN networks through the allocation of limited radio resources in a flexible manner. <b>References:</b> [105] - [106] - [107] - [108] - [109] - [117]
<b>Security</b>	Data security is one of the main requirements in 5G & beyond systems. Researchers proposed methods to preserve data integrity from data-tampering attacks by third-party eavesdroppers. Security is often interconnected with cognitive radio to improve the spectrum usage. <b>References:</b> [96] - [97] - [98] - [99] - [100] - [101] - [102] - [103] - [104]

<b>NOMA</b>	<p>NOMA revolutionized the traditional OMA techniques, since more than one user can then be served on each orthogonal carrier. Researchers investigated the advantages introduced by NOMA over integrated TN-NTN networks.</p> <p><b>References:</b> [111] - [112] - [113] - [114] - [115] - [116]</p>
<b>IoST</b>	<p>The concept of inter-communication among a large number of heterogeneous IoT devices has been extended to space. Researchers were primarily interested in CubeSats to realize a global IoST network with low cost and high flexibility.</p> <p><b>References:</b> [118] - [119] - [32] - [120] - [121] - [122] - [123]</p>
<b>SDN and NFV</b>	<p>5G features SDN to separate the control plane from the data plane, while NFV is used to implement hardware capabilities via software. Researchers considered an emerging perspective of hybrid TN-NTN networks that incorporate SDN and NFV paradigms.</p> <p><b>References:</b> [124] - [125] - [126]</p>
<b>Network Slicing Edge Computing</b>	<p>5G employs Network Slicing to provide specific network characteristics where logical networks are customized, while EC is utilized to move computing and storage resources closer to the user. Researchers integrated the two concepts with space networks to offer better scalability and lower latency.</p> <p><b>References:</b> [127] - [128] - [129]</p>

On a related matter, GEO High Throughput Satellite (HTS) and LEO satellite mega-constellations are expected to become the focus of attention for both telecommunication operators and researchers. Indeed, GEO HTSs achieving very high data rates facilitate the provision of eMBB services in Further evolved MBMS (FeMBMS) mode [130], whereas LEOs support extremely low-latency 5G services (i.e., URLLC) under low propagation delay of LEO transmissions. Therefore, GEO and NGSO satellites may be exploited either over standalone or non-standalone radio access combined with terrestrial cellular systems.

In [86], a standalone GEO satellite NG-RAN has been addressed to deliver multi-layer video services in the forthcoming 5G NR deployments by following a novel RRM strategy for efficient resource allocation that provides several multimedia video flows. Further, in [87], path-based network coding has been proposed for achieving better reliability and time-efficient distribution of traffic in TN-NTN mobile systems. A standalone LEO NG-RAN has been considered for 5G mMTC services in [88], where an uplink scheduling technique has been outlined to make the differential Doppler shift tolerable by the MTC devices.

However, the integration of LEO satellites with the 5G technology is not straightforward because of the challenging LEO features, such as Doppler effect, high-speed mobility around Earth, and smaller coverage area than for the GEO satellite. These factors lead to the construction of LEO constellations for providing global coverage. In [85], an enabling network architecture with dense LEO constellations has been designed to offer enhanced reliability and flexibility in integrated TN-NTN systems.

In a constellation, LEOs are interconnected via ISL and, owing to the on-board processing capabilities of a regenerative payload-based LEO, data transmissions may occur directly between the LEO satellites. In [89], analytical models have been coined for determining the probabilities of call blocking and handover failure in a constellation of regenerative payload-based LEOs. In the case of transparent payload-based LEO, data traffic needs to be routed to the terrestrial network, thus entailing vertical handover situations.

To ensure connection transfers without harmful interruptions over the heterogeneous wireless access technologies, seamless handover becomes a challenging matter. In [90], a strategy based on positioning has been considered to minimize the delay and to manage the inter-satellite handover in satellite communications (when a handover occurs, the nearest satellite is selected as the access satellite), whereas in [91] stochastic and deterministic optimization problems have been constructed to support handover in heterogeneous aeronautical networks with an SDN controller.

Not limited to the exponential growth of demand for high data-rate services, the 5G is characterized by a very large number of inter-connected devices. The communications among a swarm of heterogeneous devices (i.e., the Internet of Things) pave the way for a new paradigm named the IoST to efficiently incorporate the IoT concept into the space access networks. The IoST vision has been introduced in [118] to offer global connectivity by overcoming the terrestrial base station limitations [119] with low-cost and flexible solutions by combining SDN and NFV paradigms.

Indeed, NTN support broadcast/multicast IoT communications, Internet of Remote Things (IoRT) [131] applications, and Internet of Vehicles (IoV) [132] even across rural and remote areas (i.e., beyond the terrestrial coverage). Further, the important results achieved by the microelectronics and microsystems industries open a new direction for adopting smaller and more powerful satellites for the forthcoming 5G satellite era [32]. CubeSats, which originally aimed for university and research purposes [120], have been addressed over the years [121] [122]. They are now seen as a revolutionary solution to realize a global IoST network for small payload sizes, low costs (i.e., design, construction, launch, readiness for use), and high scalability [123].

In addition to SDN and NFV [124] [125] [126], 5G supports Network Slicing [133] and Edge Computing (EC) [127]. The former ensures better scalability, higher availability, and the overall resource optimization owing to the provision of specific network capabilities and characteristics with a logical network customized based on, i.e., service requirements. The latter shifts computing and storage resources closer to the user, thus supporting lower latency. These two concepts were also adopted for 5G satellite networks in [128], [129], and [134]. In [128], 5GsatEC has been proposed as a 5G satellite edge computing framework, wherein a hardware platform optimizes resources (i.e., computing, storage, network) for different services and users, whereas a software framework is built on a 5G satellite edge computing service architecture based on microservices (i.e., system, basic, and user services). In [129], edge computing has been introduced to support space-based cloud-fog satellite network slices, while edge computing nodes have been added into the computing architecture of a satellite network to reduce the delay in different slices. In [134], the authors studied an integration of CubeSats into multi-tenant scenarios by designing an SDN/ NFV IoT platform based on EC that includes CubeSat constellations.

In summary, 5G technology envisions the involvement of NTN as a means to extend terrestrial coverage and help provision for advanced services whenever and wherever the traditional cellular network is overloaded or not available. Table 3.3 classifies the related literature by a common subject matter (integrated TN-NTN networks, RRM and mobility management, etc.) under different wireless technologies. Further, Table 3.4 summarizes the research works by open research topics in the 5G & beyond fields. Finally, Table 3.5 briefly describes the main contributions of past publications on NTN and satellite communications.

Table 3.5: Brief description of published research papers on NTN and satellite communications.

---

Ref.	Short summary of the proposal	Year
[49]	Integrated S/T-UMTS architecture and RRM strategy to support data streaming and push & store services.	2004
[50]	RRM scheme to deliver MBMS services by considering satellite system requirements.	2004
[51]	RRM analysis of a dynamic channel allocation technique with queuing of handover requests.	1998
[58]	Feasibility study in terms of interference to integrate HAPS with Terrestrial UMTS system.	2003
[59]	On the importance of HAPS to support MBMS services in 3G and beyond systems.	2005
[61]	Layered approach to integrate services, radio access technologies, and protocols in satellite-terrestrial networks.	2005
[66]	Radio resource allocation scheme combining multicast subgrouping and ALJC techniques.	2018
[73]	Application of $k$ -means-based clustering to solve the precoding problem in multi-beam satellite systems.	2017
[74]	Survey on benefits and challenges of integrated satellite-terrestrial networks.	2004
[77]	Mobility management protocols to select the best network under inter-system handover.	2007
[82]	Discussion on architectural and technical issues of 5G systems.	2019
[83]	Analysis of NTN integration effects in mobile systems.	2019
[96]	Physical layer security and stochastic beamforming approach.	2018
[97]	Multi-antenna base station to enhance secure transmissions in satellite networks.	2016
[98]	Resource allocation for cooperative beamforming and artificial noise in secure satellite-terrestrial networks.	2018
[99]	Secure multicast transmission design for cognitive satellite-terrestrial systems.	2019
[100]	Cooperative secure transmission beamforming scheme maximizing the secrecy rate in TN-NTN systems.	2018
[101]	Analysis of secrecy performance of communication between multi-antenna NTN and terrestrial recipients.	2019
[102]	Adaptive transmission schemes for hybrid TN-NTN relay networks.	2019

[103]	Joint opportunistic relay selection to enhance system protection against attacks.	2018
[104]	Description of typical attack approaches to enhance security in NTN.	2019
[105]	Non-cooperative game for spectrum sharing between NTN and terrestrial networks.	2019
[106]	Outage analysis in a cognitive TN-NTN network.	2017
[107]	Outage probability and ergodic capacity derivation for a cognitive TN-NTN network.	2019
[108]	Full cooperative relay protocols to characterize the ergodic capacity.	2017
[111]	Survey on multi-satellite cooperative transmission systems based on NOMA.	2018
[112]	Ergodic capacity formulation for NOMA-based uplink NTN systems.	2019
[113]	Ergodic capacity and outage probability for a hybrid TN-NTN relay network with cooperative NOMA scheme.	2019
[114]	Analysis and derivation of a closed-form expression for outage probability.	2019
[115]	Capacity computation for a NOMA-based TN-NTN system.	2017
[116]	Optimization of NTN multicast communications sharing spectrum with terrestrial communications.	2019
[87]	Path-based network coding to improve reliability in TN-NTN mobile systems.	2019
[88]	Standalone LEO NG-RAN and uplink scheduling technique to handle Doppler shift in 5G mMTC scenarios.	2019
[85]	Network architecture with a dense LEO constellation for reliable and flexible integrated TN-NTN systems.	2019
[89]	Analytical models to determine call blocking and handover failure probabilities in a LEO constellation.	2018
[91]	Stochastic and deterministic optimization problems to support handover in heterogeneous aeronautical networks.	2019
[118]	Introduction of the Internet of Space Things.	2019
[119]	SDN and NFV as low-cost and flexible solutions to provide global connectivity.	2017
[131]	Introduction of the Internet of Remote Things in satellite communications.	2016

[132]	Computation offloading mechanism for 5G Satellite-ground IoV systems.	2019
[120]	CubeSats as cost-effective science and technology platforms.	2011
[123]	Realization of global IoST networks with CubeSats.	2019
[124]	Introduction of softwarized networking and virtualization into satellite networks.	2015
[128]	Edge computing framework over 5G satellite architecture.	2019
[117]	Single-Frequency Multi-Beam Transmission of eMBMS services over 5G NR multi-beam NTN systems.	2020

### 3.6 Current 3GPP Research Activities

Activities on NTN inside the 3GPP RAN and System Aspects (SA) Technical Specification Group (TSG) started in 2017 under Release 15 and are still ongoing. A RAN-level 3GPP study on NTN NR was completed in December 2019 and the normative work started in August 2020 for Release 17. Conversely, the SA work depends on the progress in RAN groups and may proceed further after the normative RAN-level work progresses. Table 3.6 lists the features and study items on NTN as investigated by the 3GPP from Release 15 to Release 17. In particular, each 3GPP feature or study item is associated with the *lead body* (i.e., 'R' for RAN aspects and 'S' for system aspects). The *completion* field indicates when the 3GPP feature or study item was completed or is expected to be completed.

3GPP technical reports and specifications related to NTN are as follows:

- TR 38.811 [3] defines the NTN deployment scenarios and the related system parameters (i.e., architecture, altitude, orbit, among others), adapts the 3GPP channel models for NTN, describes the deployment scenarios, and identifies the key impact areas for the NR interface.
- TR 38.821 [2] studies a set of necessary features/adaptations enabling the operation of the NR protocol in NTNs with a focus on satellite access. An access network based on UAS and including HAPS may be considered as a special case of non-terrestrial access with lower delay/Doppler value and variation rate. The objectives of this work are the consolidation of potential impacts on the physical layer and definition of the related solutions, performance assessment of 5G NR in selected deployment scenarios (LEO satellite access, GEO satellite access) through link-level

and system-level simulations, solutions for 5G NR related to Layer 2 and 3, and solutions for the RAN architecture and the related interface protocols.

- TR 22.822 [34] supports service continuity between the terrestrial NG-RAN and the NTN-based NG-RAN owned by the same operator or subject to an agreement between operators. This TR aims at identifying the use cases for the delivery of services when considering the integration of NTN-based access components into the 5G system and, consequently, new services and requirements (i.e., setup, configuration, maintenance, and regulation).
- TS 22.261 [135] describes the service and operational requirements for a 5G system, which includes UE, NG-RAN, and 5G core network components.
- TR 23.737 [136] identifies the impact areas of satellite integration into the 5G system when considering the use cases of the TR 22.822 [34]. It finds solutions to adapt the 5G system for three use cases (i.e., roaming between terrestrial and NTN systems, 5G Fixed Backhaul between NTN-based NG-RAN and 5G Core, and resolution of issues related to NG-RAN and 5GC).
- TR 28.808 [137] identifies the key issues associated with the business roles, services, and management and orchestration in a 5G network with integrated satellite components. It studies the associated solutions, aims at minimizing the complexity of satellite integration into the existing business models, as well as considers the management and orchestration aspects of the current 5G networks.

In [78] and [138], adaptation of 5G NR for satellite communications was considered based on the Release 15 of NR specifications. The work in [78] focused on physical layer and user plane aspects, while [138] described the challenges related to the connected mode and idle mode mobility as well as captured the NR specific network architecture aspects in both GEO- and NGSO-based NTN systems.

The longer delay associated especially with GEO deployments poses challenges for the random access procedure as well as hampers all the RRC procedures. For example, delay causes considerable data transmission interruptions during handovers. Moreover, as HARQ retransmissions add up to the delay, it has been proposed to disable HARQ in certain cases. All user plane protocols require adjustments due to longer propagation delays. Furthermore, both timing and frequency corrections are needed, especially for the UL transmissions, so the gNB receives the UL transmissions in the exact time/frequency resources allocated for a given UE.

For LEO satellite systems, the movement of a satellite, and thus the beam footprint at low orbit, bring new issues to be addressed. For example, in terrestrial systems, all network identities are assumed to remain fixed in geographical areas. Hence, a gNB

**Table 3.6.** List of 3GPP Features and Study Items on NTN.

Release	Lead Body	Feature and Study Item	Completion
15	R1	Study on NR to support Non-Terrestrial Networks	2018-06-15
16	R3	Study on solutions for NR to support Non-Terrestrial Networks	2019-12-15
	S1	Integration of satellite access in 5G	2018-06-06
17	S2	Study on architecture aspects for using satellite access in 5G	2020-06-25
	S5	Study on management and orchestration aspects with integrated satellite components in a 5G network	2020-06-12 (65%)
	R1	Study on NB-IoT/eMTC support for Non-Terrestrial Networks	exp. 2021-06-15
	S2	Integration of satellite components into the 5G architecture	exp. 2020-09-12
	R2	Solutions for NR to support Non-Terrestrial Networks	exp. 2021-12-15

covers and serves a fixed geographical region, while in LEO systems the cells (i.e., beam footprint) move over the ground. In both LTE and NR, the UE in IDLE mode reads from system information, under which tracking area it is located. If the current tracking area code is different from the tracking area code that the UE is registered with, it needs to perform a tracking area update and inform the network about its new tracking area. In the case of an incoming call, the network pages the UE at the tracking area, which the UE has last indicated.

Further, as the LEO satellite orbits Earth, its connected ground node needs to be switched from time to time. For the regenerative LEO, this implies that the gNB changes the ground connection. For the transparent LEO, this means that the geographical area covered by the gNB on the ground is altered. When the feeder link switches, enhancements to the network signaling as well as to the signaling toward the UE are required.

### 3.7 Open Issues and Future Directions

In this section, we discuss the main open issues and pave the way to future research directions. In particular, we focus on the management of mobility, propagation delay,

and radio resources. Table 3.7 summarizes some of the open questions discussed in the following subsections.

Table 3.7: Open issues in NTN.

Feature	Effect	Impact	Issues & Directions
<ul style="list-style-type: none"> <li>· NGSO satellite motion</li> </ul>	<ul style="list-style-type: none"> <li>· Cell pattern motion</li> </ul>	<ul style="list-style-type: none"> <li>· Handover</li> <li>· Paging</li> </ul>	<ul style="list-style-type: none"> <li>· <i>Mobility management</i>: new solutions for frequent handover mechanisms in NGSO satellite networks.</li> <li>· <i>Tracking area management</i>: new methods to provide exact information on UE Tracking Areas during Initial Registration and UE locations during Registration Update and Paging.</li> </ul>
<ul style="list-style-type: none"> <li>· NTN platform altitude, orbit, and motion</li> <li>· NTN gateway position and elevation</li> <li>· NTN terminal position, antenna type, and motion</li> </ul>	<ul style="list-style-type: none"> <li>· Propagation delay</li> <li>· Varying NTN channel</li> </ul>	<ul style="list-style-type: none"> <li>· Channel estimation</li> <li>· Scheduling</li> </ul>	<ul style="list-style-type: none"> <li>· <i>Delay-CSI-MCS management</i>: new techniques to select transmission parameters (i.e., MCS) to ensure that UE may perceive satisfactory service quality and reliably decode transmitted data despite rapid channel fluctuations and long propagation delays.</li> <li>· <i>Ephemeris data management</i>: new solutions to efficiently provide and update the UE with the required ephemeris data, which may be substantial.</li> </ul>

<ul style="list-style-type: none"> <li>· NGSO satellite motion</li> <li>· NTN gateway position and elevation</li> </ul>	<ul style="list-style-type: none"> <li>· Connection drops between NGSO satellite and NTN gateway</li> </ul>	<ul style="list-style-type: none"> <li>· Feeder link switch-over</li> </ul>	<ul style="list-style-type: none"> <li>· <i>Feeder-link management</i>: enhancements to both network signaling and signaling to the UE are needed to efficiently perform a seamless feeder link switch-over.</li> </ul>
<ul style="list-style-type: none"> <li>· New available frequency bands</li> <li>· Scalable NR numerology</li> <li>· Hybrid/integrated TN-NTN networks</li> <li>· Multi-beam HTS</li> </ul>	<ul style="list-style-type: none"> <li>· Interference</li> <li>· Non-null side lobes of beam radiation patterns</li> </ul>	<ul style="list-style-type: none"> <li>· Resource allocation</li> </ul>	<ul style="list-style-type: none"> <li>· <i>RRM and interference management</i>: new approaches for allocating radio resources to avoid inter-RAN interference (e.g., between two RANs of an integrated/hybrid TN-NTN network), intra-NTN inter-beam interference (e.g., among beams of the HTS), and inter-NTN interference (e.g., among satellites of the NTN). Further, novel methods of radio spectrum utilization are demanded to manage the availability of new 5G frequency bands and the introduction of scalable NR numerologies to avoid inter-numerology interference.</li> </ul>

### 3.7.1 Mobility Management

NGSO satellites are characterized by shorter propagation delays and higher data rates than GEO satellites. Hence, they are considered to be an effective solution to enhance the 5G terrestrial networks. However, the motion of both the NGSO satellites around Earth and the UEs in a given region yields a time-varying NGSO channel. The dynamic nature of NGSO satellite links has an important implication on handover and paging procedures. As shown in Fig. 3.7, handover can belong to one of the following categories:

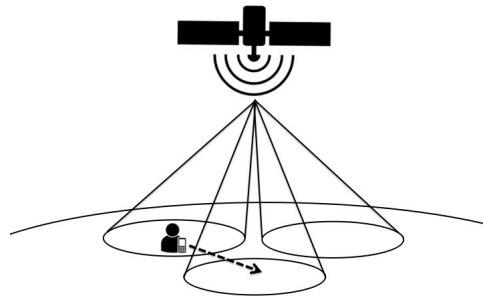

(a) Intra-satellite

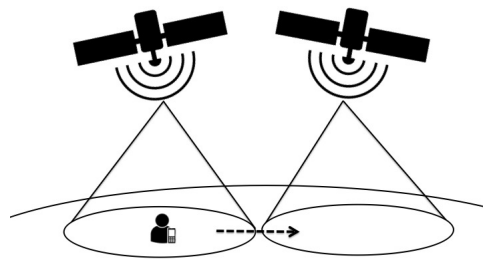

(b) Inter-satellite

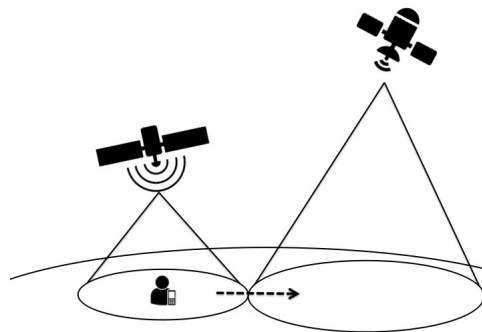

(c) Inter-access network

**Fig. 3.7.** Types of handover.

- *Intra-satellite handover* occurs between satellite beams. In the case of NGSO satellites, frequent intra-satellite handovers are related to high speeds of the beam footprint on the ground.
- *Inter-satellite handover* occurs between satellites and is essentially related to the limited geographical coverage of NGSO satellites.

- *Inter-access network handover*, also known as vertical handover, occurs either between satellites belonging to different access networks or from the NGSO satellite to the gNB (or vice versa) in integrated TN-NTN systems.

The paging issue is primarily related to the tracking area management [2]. The tracking area is the satellite coverage area; it can be fixed (for both GEO and NGSO satellites) or moving (for NGSO satellites). The moving tracking area incurs high paging loads that are difficult to manage by the network. Indeed, the NGSO beam footprints do not correspond to the terrestrial cells on the ground. As a consequence, the NGSO satellite-based RAN is not able to provide the exact information on the UE tracking area during the initial registration. Furthermore, the UE cannot always establish its location for Registration Update and Paging procedures.

In recent years, several research works addressed mobility management. One of the main objectives was to coin handover solutions over LEO satellite networks, since handovers frequently occur because of the LEO features, i.e., LEOs are positioned at low altitudes, provide limited coverage, and rapidly move around Earth. In [139], the authors modeled the handover process and proposed a strategy for inter-beam satellite handover based on the potential game for mobile terminals to minimize the number of handovers, balance the LEO constellation load, and reduce the handover time.

In [140], the authors introduced a Virtual Agent Cluster (VAC) to manage handovers and construct the Home Mobile-Agent-Anchor (HMAA) and the Local Mobile-Agent-Anchor (LMAA) to let users share their location information. To avoid handover failures, the authors in [141] formulated a novel method of handover prediction based on the UE velocity that is non-negligible in LEO satellite networks. In [142], three algorithms have been designated to consider the handover time, the route update frequency, and the relay satellite configuration in global navigation satellite systems.

None of the works in past literature considered the 5G NR. Future studies might integrate the NR technology with the NTN to improve compatibility with 5G NR terrestrial networks. New procedures to support dual-connectivity and novel mechanisms for vertical handovers might be proposed to improve global network coverage, service continuity, and seamless mobility in hybrid/integrated terrestrial and NTN systems. Further, solutions for UE geolocation are required to determine the belonging beam (satellite), the beam (satellite) belonging time, and the next-to-switch beam (satellite) to simplify handover and paging procedures.

### 3.7.2 Propagation Delay Management

The propagation delay has a profound impact on the system performance in non-terrestrial communications and can be considered as one of the main challenges for URLLC applications and critical communications (i.e., public safety). The propagation delay is defined as the latency either from the NTN gateway to the NTN terminal via space/airborne platform (i.e., transparent payload) or from the space/airborne platform to the NTN terminal (i.e., regenerative payload). Furthermore, the propagation delay depends on the NTN platform altitude, the NTN gateway position and elevation angle, and the NTN terminal position [3]. It can also be distinguished as follows:

- *One-way propagation delay* considers the time needed by the information to travel from the NTN gateway to the NTN terminal through the NTN platform (in the case of the transparent payload-based satellite) or from the NTN platform to the NTN terminal (in the case of the regenerative payload-based satellite).
- *Two-way propagation delay*, also known as Round Trip Time (RTT), takes into account the time required by the information to travel from the NTN gateway to the NTN terminal through the NTN platform and back (in the case of the transparent payload-based satellite) or from the NTN platform to the NTN terminal and back (in the case of the regenerative payload-based satellite).

Furthermore, the propagation delay is a crucial parameter to be considered during the choice of transmission parameters (i.e., MCS). In NGSO satellite-based communications, the UE radio channel is characterized by rapid fluctuations over time; hence, after the propagation time has elapsed, the UE may no longer be able to decode the received data or can perceive an undesired QoS.

In recent literature, several works considered imperfect channel estimation over satellite networks. In [143], the authors quantitatively evaluated the effect of imperfect CSI in terms of the outage probability and ergodic capacity in a cognitive satellite-terrestrial network. In [144], the authors considered the CSI imperfections to formulate a closed-form expression for the outage probability in a hybrid satellite-terrestrial relay network based on NOMA. To allow for data transmissions over multi-way satellite relaying systems, the authors in [145] formulated a novel method of channel estimation.

The NTN channel is modeled by considering relative movements of both the NTN platform and the UE, NTN altitude and orbit, UE antenna type, atmospheric conditions, presence or absence of obstacles (i.e., building, foliage, mountains), deployment scenario, and frequency bands. In future research activities, it might be essential to investigate the ways how these factors lead to changes in the user channel as well

as how to cope with abrupt channel variations by considering propagation delay to ensure service continuity.

### 3.7.3 Radio Resource Management

Radio resource management is one of the major considerations in 5G NR technology. Hence, efficient radio resource allocation is essential to avoid the following:

- *Intra- NTN inter-beam interference.* The success of HTS is driven by the multi-spot-beam technology that leads to improved capacity. However, efficient frequency reuse is required to avoid interference between the adjacent beams.
- *Inter- NTN interference.* In the case of heterogeneous NTN systems, when an NGSO satellite enters the LoS conditions with the GEO satellite, dynamic RRM techniques aid in coping with mitigating interference between the GEO and the NGSOs inside the GEO LoS cone.
- *Inter radio access network interference.* The integration of NTNs with terrestrial systems may be exploited in many 5G scenarios to extend cellular coverage or to offload terrestrial traffic. In the latter case, radio resources need to be allocated to limit the interference between the GEO (or NGSO) and the gNBs.

In recent years, researchers mostly investigated techniques to mitigate inter-beam interference in multi-spot-beam based HTS. In several works, precoding strategies have been introduced to reduce the interference at the NTN receivers due to non-null beam side lobes. Multicast precoding approaches have been summarized in [146]. Among them, the multicast multigroup problem in frame-based multi-beam NTN has been considered in [147], where a low-complexity precoder has been proposed. In [148], the authors maximized the satellite system throughput by solving an optimization frame-based precoding problem.

In [73], two solutions based on  $k$ -means clustering algorithm have been formulated to group users in the same cluster according to their similarity in terms of the Euclidean distance and their channel coefficients. A mathematical framework for the throughput maximization facilitated the user clustering in [149], whereas in [150] multicast precoding problem has been solved with a novel geographical scheduling scheme. Recent research results on radio resource management were reported in [151], [152], and [117].

In [151], a new genetic algorithm considered the propagation effects, interference among beams, and atmospheric attenuation. In [152], a novel power resource allocation scheme has been proposed and a mathematical model has been constructed for ensuring

the trade-off between the transmit power and the beam directivity. In [117], the authors introduced an emerging RRM technique, named Single-Frequency Multi-Beam Transmission (SF-MBT), to simultaneously deliver eMBB services into the dedicated Beam Areas over 5G NR multi-beam NTN systems.

The availability of new frequency bands (i.e., mm-Wave) and the introduction of scalable 5G NR numerology [22] led to additional challenges in the management of the radio spectrum for NTN systems. Indeed, different numerologies (i.e., different subcarrier spacings) may coexist over a given frequency band, thus generating novel types of interference, known as Inter-Numerology Interference (INI) [153]. In recent literature, several works analyzed the INI factors that impact the overall performance [154]. INI cancellation methods for 5G NR multi-numerology terrestrial systems were also investigated [155].

5G NR over NTN is expected to be introduced in 3GPP Release 17 by following the outcomes of the preceding study items [156]. Release 17 is also planned to include a study item on NB-IoT for NTN [157]. Therefore, the research community might address the issue of INI mitigation in multi-numerology NTN systems for 5G and beyond technologies. Future research activities can focus on new solutions to boost the capacity by limiting inter-beam interference in multi-spot-beam satellite systems. Finally, novel radio resource allocation techniques might be required to handle the transmission of several services and to cope with inter radio access network interference in hybrid/integrated TN-NTN systems.

### 3.8 Toward 6G Satellite Communications

ITU has already started work on Network 2030 [158] with the aim to merge digital and real worlds across all dimensions. In addition to the 5G macro-categories (i.e., eMBB, mMTC, and URLLC), emerging 6G applications may include the following:

- *Holographic Type Communications (HTC)* require very high bandwidths to achieve excellent quality of hologram data transmitted from remote sites.
- *Multi-Sense Networks* involve not only acoustic, optical, and tactile senses but also the sense of smell and taste for a fully immersive experience.
- *Time Engineered Applications*, such as industrial automation, autonomous systems, and massive sensor networks, where the time factor is extremely important for real-time response.
- *Critical Infrastructure*, where critical safety operations are essential in emergency areas.

Space communications can thus become a promising enabling feature not only for 5G but also for the future 6G wireless technology. Indeed, the integration of spaceborne and airborne platforms with terrestrial networks may achieve even more success in 6G [159] [160]. Among the NTN platforms, drones might be primarily exploited to complement the terrestrial coverage by providing connectivity to hotspot areas and in scenarios with weak terrestrial signal. Further, NGSO satellites have the potential to support drones and terrestrial gNBs in backhauling and coverage extension.

Integrated NTN-terrestrial networks can benefit from wide-area coverage, predominant LoS, as well as low-loss and high-throughput transmissions. 6G-enabled NTN may also adopt new technologies, such as laser- mm-Wave, optical, and holographic type communications, photonics-based cognitive radio, machine learning, and Artificial Intelligence, all to achieve further enhanced low-latency and high-reliability during space-Earth transmissions [161]. A future vision of satellite communications might embrace the following 6G enabling features:

- *Holographic radio* to control the physical space owing to Large Intelligence Surface (LIS) [162] by improving spectral efficiency and network capacity.
- *Non-Radio Frequency* to compensate for wavelength distortion due to atmospheric phenomena as well as to offer ultra-low latency and high reliability.
- *Artificial Intelligence* for real-time satellite decisions and seamless satellite control to achieve high-level autonomous operations.

Table 3.8: Vision of satellite communications from 1G to 6G.

Technology	Novelty	Description
1G	· Voice · Low data-rate applications	Satellite systems are considered independently from terrestrial systems due to their features (i.e., covered distance, exploited radio spectrum, design, cost, applications, and targets).
2G	· Aeronautical and maritime services	Satellite coverage is limited to areas unreachable by terrestrial networks. Therefore, satellites remain proprietary and in competition with traditional cellular networks.
3G	· Broadband and multimedia services	3G technology makes the first step toward the convergence of satellite and terrestrial networks (i.e., satellite air interface is fully compatible with terrestrial UMTS network infrastructure).

4G	<ul style="list-style-type: none"> <li>· Hybrid/integrated satellite-terrestrial networks</li> <li>· HTS</li> </ul>	Satellite communications are considered indispensable for achieving global roaming where terrestrial network infrastructure is impossible to be installed or is economically expensive.
5G	<ul style="list-style-type: none"> <li>· SDN/ NFV based TN-NTN networks</li> <li>· IoST</li> <li>· Cognitive TN-NTN networks</li> <li>· NOMA based TN-NTN systems</li> </ul>	Integration of NTN with terrestrial networks is a means to provide connectivity anywhere and anytime. To achieve this goal, the following requirements need to be provided: <ul style="list-style-type: none"> <li>· <i>multi-connectivity</i> allows users to be served by the two or more different RANs simultaneously (i.e., NTN and terrestrial network);</li> <li>· <i>service continuity</i> ensures smooth handover between different RANs.</li> </ul>
6G	<ul style="list-style-type: none"> <li>· NTN based on holographic radio</li> <li>· NTN based on non-radio frequencies (i.e., optical)</li> <li>· Satellite communications based on Artificial Intelligence.</li> </ul>	Space-aerial-terrestrial networks may achieve even higher success in 6G. Drones can be exploited as base stations to provide connectivity in hotspots and remote areas and can be supported by NGSO satellites in backhauling and coverage extension. Since several features are to be introduced in 6G, satellite communications might be revolutionized with holographic radio, non-radio frequency, and Artificial Intelligence.

In 6G wireless, NTN communications may become essential to ensure extreme flexibility and integration of terrestrial and satellite networks. Here, the 6G NTN is expected to support emerging critical use cases (i.e., disaster prediction) and achieve global connectivity with seamless network access in maritime and mountainous scenarios. To offer a more systematic view on space communications, Table 3.8 surveys the role of NTN over the technological eras, from 1G satellites to how satellite networks may evolve in the future toward 6G.

Finally, Fig. 3.8 illustrates the vision of NTN in 5G and beyond technologies.

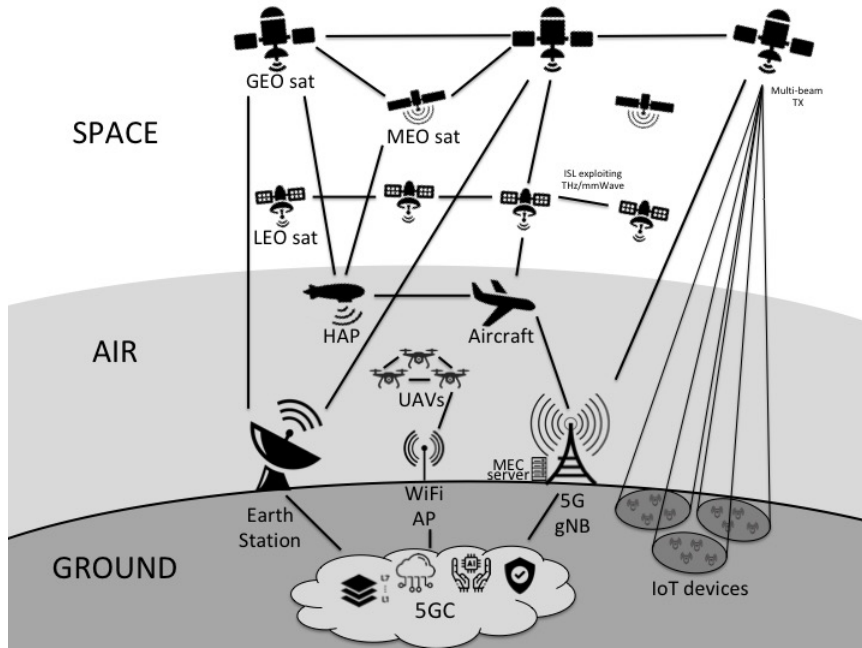

Fig. 3.8. Role of NTNs in 5G and beyond.

### 3.9 Conclusions

The last decade of progress in telecommunications has been characterized by the rapid proliferation of smart devices, the important technological advancements, and the exponential growth of demand for new services. These developments fueled the interest of both Information and Communications Technology (ICT) operators and researchers in the NTN systems as a means to provide ubiquitous services by achieving global network coverage. The relevance of NTN across their two design options (i.e., standalone satellite vs. integrated terrestrial and non-terrestrial architecture) is expected to raise further in beyond- 5G ecosystem.

The objective of this chapter is to provide a holistic overview of the NTN evolution in connection to cellular communications – initially from 1G to 4G – by investigating the central research topics, such as the integration of non-terrestrial and terrestrial networks, the radio resource allocation, and the mobility. This study also highlights the importance of NTN in 5G technology by further focusing on its role toward 6G, and contributes a summary of the current 3GPP research activities in supporting the NTN as part of the 5G NR technology. Notably, the NTN demonstrates certain unique effects due to its individual characteristics, i.e., long propagation delay, motion of NGSO satellites, and many others. In due course, this chapter finally elaborates main open issues (mobility, propagation delay, and radio resource allocation) with the purpose of understanding future attractive research directions.

## Broadcasting Services over 5G NR Enabled Multi-Beam Non-Terrestrial Networks

*The era of the 5G NR technology has just begun, and its promises to substantially improve the system performance have turned into reality. The 5G NR enabled NTN is almost upon us and will represent an effective solution to provide services anytime, anywhere, and over wider coverage areas. In this context, high throughput satellite systems with advanced multi-beam transmissions have gained significant attention owing to their ability to boost the system capacity through beam frequency re-use, increased user data rates, and system spectral efficiency. In this chapter, we propose a novel radio resource management scheme, named Single-Frequency Multi-Beam Transmission (SF-MBT), for efficient delivery of the eMBB services over the 5G NR multi-beam NTN systems. The main thinking is to group beams into the dedicated Beam Areas, wherein a certain content flow is delivered via simultaneous multi-beam transmissions over the same radio resources without causing inter-beam interference. A simulation campaign is conducted under different scenarios to assess the effectiveness of the proposed SF-MBT algorithm as compared to the current schemes based on frequency reuse. System-wide performance is evaluated in terms of the aggregate data rate, mean throughput, and system spectral efficiency.*

### 4.1 Introduction

The growing interest in NTN technology [2] by both telecommunications operators and the broader research community has been fueled by the rapid evolution of telecommunication technologies, the continuous demand for new services, and the increasing number of smart devices. NTN is expected to become an effective solution to support terrestrial networks in service provisioning by satisfying the stringent performance requirements and ensuring high QoS expectations for all users even when traveling on cruises, trains, and airplanes. Indeed, NTN extends terrestrial coverage to under-

served zones to achieve anytime and anywhere connectivity, which is a key feature for next-generation telecommunication systems.

In the past few years, the demand for certain types of service has increased dramatically and it is expected to grow further in the coming years. In particular, the Ericsson Mobility Report [6] forecasts that mobile traffic will grow by 30% annually between 2018 and 2024, and most of this increase will come from video services. This uphill trend is mainly driven by the volume of embedded video in online applications, the growth of VoD streaming services, the adoption of higher screen resolutions, and the large number of smart devices being connected to the mobile network.

In this context, handling numerous devices that require different broadcast services [163] could be challenging in terms of both capacity and radio spectrum management. To boost the system capacity and to efficiently exploit the spectrum, the traditional FSS based on single-beam transmissions has evolved into HTS technology, featured by multi-beam deployments, wherein the radio frequency is re-used across multiple beams to avoid inter-beam interference. Today, the multi-beam NTN systems mostly exploit the four-color frequency re-use scheme where four different frequencies are shared by the beams [73].

In this chapter, we propose a new Single-Frequency Multi-Beam Transmission (SF-MBT) scheme as a promising RRM approach for efficient exploitation of the radio spectrum when delivering the eMBB services in multi-beam NTN systems based on the emerging 5G New Radio (NR) technology. The designed SF-MBT algorithm groups the beams into areas according to the NTN terminal interests and performs efficient multi-content radio resource allocation by avoiding interference among the beams belonging to more areas. The key objective of our SF-MBT scheme is to improve the multi-beam NTN performance in terms of Aggregate Data Rate (ADR) as compared to the current frequency re-use approaches.

The remainder of this chapter is organized as follows. In Section 4.2, we introduce the state of the art, including the motivation behind this work, the main related literature on multi-beam satellite systems, and our contributions. In Section 4.3, we outline the reference system model and detail both the 5G NR multi-beam NTN and the channel models. Our proposed RRM scheme and its computational complexity are discussed in Section 4.4. An extensive analysis of the performance results is provided in Section 4.5. Finally, conclusions are drawn in Section 4.6.

## 4.2 State-of-the-Art Review

### 4.2.1 Motivation

Improvements in satellite manufacturing technology coupled with the growing demand for anytime and anywhere services draw the attention of telecommunications operators and research organizations to NTN solutions that will integrate with the 5G NR systems. 5G NTN [3] is required to offer wider area coverage, improve service continuity for both massive MTC devices and human users traveling on-board moving platforms, and help enhance service availability in mission-critical use cases (such as natural disasters, failure recovery, and public safety). Furthermore, the 5G NTN may increase network scalability by delivering multicast/broadcast services, i.e., eMBMS [69], to groups of NTN terminals through Point-to-Multipoint (PtM) connections.

In recent years, the telecommunication research community has been specifically interested in investigating multi-beam NTNs (i.e., HTSs) [8]. In such systems, frequencies are re-used among beams and the available frequency bands depend on the frequency re-use factor that determines how many and which frequency sets are re-used across the beams. The frequency re-use factors of one (i.e., full frequency re-use scheme), two (i.e., four-color frequency re-use scheme), or three (i.e., three-color frequency re-use scheme) are the available 3GPP options [2].

Over the following years, multi-beam NTNs are expected to play a crucial role in the eMBMS provisioning due to their ability to achieve higher data rates. Moreover, eMBMS will also be provided in the Single Frequency mode (MBSFN [164]) with prior network synchronization. Multi-beam NTN and MBSFN demonstrate important benefits by revolutionizing the traditional cellular networks and the conventional Point-to-Point (PtP) transmission mode, respectively. Indeed, NTN takes advantage of wider area coverage as compared to the terrestrial network, whereas MBSFN benefits from more efficient radio spectrum usage since the same content is sent to multiple users only once over the same radio resources, thus limiting the interference.

It is essential to note that multicast/broadcast transmissions are not yet supported in the present 3GPP Release 15 [165]. The work on Release 16 is currently ongoing and eMBMS will be introduced for the 5G NR access technology in Release 17 [166]. Furthermore, NR over NTN is being specified in Release 17, following the outcome of the preceding study items [156]. Hence, this work aims to stimulate future investigations by the research community on multicast/broadcast transmissions in the single-frequency mode over multi-beam NTN systems.

### 4.2.2 Related Work

One of the most explored issues in multicast transmissions is the support for AMC, which is the link adaptation procedure for setting transmission parameters on a per-group basis (i.e., the content is delivered with the most robust modulation supported by all of the target users). In the literature, multiple AMC approaches were proposed for single-beam satellite networks. For instance, the conservative approach or Conservative Multicast Scheme (CMS) [167] adapts the transmission to users with the worst channel quality by guaranteeing fairness but suffers from low spectral efficiency.

With the opportunistic approach or Multicast Link Adaptation (MLA) [168], part of the multicast group is being served in a time slot to optimize a given cost function (i.e., throughput maximization). Multicast Subgrouping (MS) [67] aims to split the multicast group into subgroups, wherein users are combined according to the channel similarity and served in each time slot. In [169], a new MS policy is proposed for the maximization of the Multicast Subgrouping – Maximum Satisfaction Index (MS-MSI) to achieve the trade-off between throughput and fairness, whereas an RRM scheme that combines the MS approach with the ALJC technique [68] is offered in [66] aiming to improve the quality of multicast transmissions over the satellite eMBMS networks.

Satellite systems based on multi-beam transmissions represent an evolution of the single beam-based satellites (i.e., FSS) to increase the system capacity and improve radio resource utilization. Multi-beam transmissions are based on the principle of frequency re-use; hence, the nearby beams exploit different bandwidths to avoid inter-beam interference. The latter occurs when the same frequency is used by all of the beams, thus limiting the HTS system performance. Therefore, satellite operators allocate dissimilar frequency bands to the adjacent beams according to a given frequency re-use scheme. To limit inter-beam interference, several solutions were considered in past literature.

Appropriate RRM approaches are one of the options to mitigate the inter-beam interference. In [170], a scheme for resource allocation (i.e., transmit power, bandwidth, and modulation parameters) that takes into account the user locations and, therefore, different radio propagation conditions, is proposed for multi-beam satellite systems. To compensate for the impact of a varying channel on the performance degradation in multi-beam satellite communications, a channel estimation method and a detection technique are developed in [171]. An adaptive bandwidth adjustment is performed in [70], where a dynamic bandwidth allocation scheme is proposed for multi-beam satellite systems by assuming uniform signal attenuation across each beam to achieve a

trade-off between the maximum capacity and the fairness among beams under different traffic demands.

In [172], the authors propose a dynamic channel allocation algorithm and formulate an optimization problem based on deep reinforcement learning techniques to minimize the service blocking probability in multi-beam satellite networks. In [151], a genetic algorithm is designed for the allocation of both power and bandwidth by considering the propagation effects, interference among beams, and atmospheric attenuation. A mathematical model is constructed in [152] aiming at characterizing the trade-off between the transmit power and the beam directivity to increase the flexibility in handling traffic demands; further, a novel power allocation scheme is also devised.

Pre-coding is another technique to mitigate the interference among users located at the beam edges due to the existence of side lobes in beam radiation patterns. In [173], the authors provide an optimal solution to the linear pre-coding problem by proposing a generic iterative algorithm that optimizes both pre-coding vectors and power allocation. In [146], an overview of multicast multigroup pre-coding techniques and user clustering methods is provided for multi-beam satellite communications. Multicast multigroup pre-coding and user scheduling remain the main topics in [148] and [147]. In [148], the authors formulate an optimization frame-based pre-coding problem that aims at maximizing the throughput of a satellite system under given power constraints and at proposing a multicast-aware user scheduling policy.

In [147], the authors investigate the problem of multicast multigroup transmission in frame-based multi-beam satellite systems by proposing a low complexity pre-coder for minimizing the robust power by considering – differently from [148] – the Channel State Information at the Transmitter (CSIT) for user clustering. To overcome the effect of imperfect CSIT due to long propagation delays, a low complexity two-stage pre-coding scheme is delivered by [174] to limit the interference among beams. Grouping users within a cluster to serve them simultaneously in the same frame is the aim of [73], where two  $k$ -means based clustering approaches are employed according to two similarity metrics based on the Euclidean distance and the channel coefficients.

In [149], the problem of user clustering is addressed by introducing a novel mathematical framework suitable for maximizing the overall throughput for the two designed clustering algorithms (i.e., those for fixed-size and variable-size clusters). Differently from past research, which is focused on the design of multicast multigroup pre-coding or user clustering algorithms, the work in [150] analyzes the impact of the system scheduler on multicast pre-coding and develops a geographical scheduling scheme to

improve the performance of multicast and unicast pre-coding in terms of the average spectral efficiency with respect to the random scheduling approach.

### 4.2.3 Our Contributions

In the existing literature, two key approaches (i.e., RRM and pre-coding techniques) are considered to limit the inter-beam interference at the NTN receivers due to non-null side lobes of the beam radiation patterns. In this chapter, we propose another solution for mitigating the interference between the NTN terminals at the beam edges by exploiting simultaneous MBSFN transmissions among the synchronized beams of the same satellite to deliver the given content over the same radio resources. Therefore, multiple signal waveforms belonging to different beams are considered as a source of constructive interference at the NTN receiver.

To the best of our knowledge, the MBSFN approach has not been considered before for multi-beam satellite communications.

In this chapter, we thus provide the following contributions:

- First, we define the concepts of MBSFN beam transmission, Synchronized Beam Area (SBA), and MBSFN Beam Area (MBA), based on which we design a novel algorithm for MBA formation that aims at increasing the ADR in a multi-beam NTN system. In each MBA, the beams are synchronized in time to deliver the same eMBB flow to several NTN terminals over the same radio resources (i.e., MBSFN transmission<sup>1</sup> is performed by multiple beams).
- Second, we propose a radio resource allocation technique that avoids inter-beam interference when delivering several items of content. We consider the mobility of NTN terminals and thus channel quality variations over time. The channel status reports of NTN terminals are essential for setting the transmission parameters, i.e., modulation and coding scheme. The latter is determined by considering the propagation delay.
- Finally, since none of the proposals in past literature are ready for the 5G NR systems, we tailor our system model to account for the 5G NR technology. With an extensive simulation campaign, we evaluate and compare the system performance of our proposed approach against two alternative frequency re-use schemes.

---

<sup>1</sup> The MBSFN transmission or the transmission in the MBSFN mode has been specified in [130] for cellular broadcasting as a simulcast transmission technique where identical waveforms are transmitted at the same time from multiple cells.

### 4.3 System Model

As demonstrated in Figure 4.1, we refer to a multi-beam NTN radio access architecture supporting multicast transmissions where the NTN platform communicates with the NTN terminals via the NR-Uu radio interface and is connected to the 5GC through the NTN Gateway.

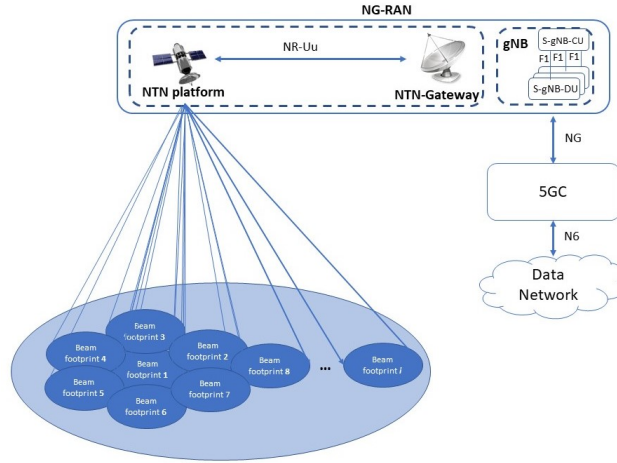

**Fig. 4.1.** Reference architecture for multi-beam transmission in single-frequency mode.

#### 4.3.1 5G NR Multi-Beam NTN Model

We consider a GEO Satellite equipped with a transparent payload (GEO-sat) equipped with a transparent payload [2] operating in the S-band frequency (i.e., 2 GHz) as a reference NTN platform. The ground component of the GEO-sat is the GEO-gNB that is responsible for the link adaptation procedures. In particular, GEO-sat collects and forwards all the CSI feedback from the NTN terminals to the GEO-gNB, which selects the appropriate MCS for the delivery of a given eMBB content to multiple destinations.

The CSI feedback of the NTN terminals is transmitted via the feeder link, which is denoted as the link from the NTN terminals to the GEO-gNB. The eMBB data are transmitted via the service link, which is denoted as the link from the NTN-gNB to the NTN terminals. The Round Trip Delay (RTD) is the time required for a signal to travel from the NTN-terminal to the NTN-gateway and back (or vice versa). For a transparent payload-based satellite, the MBSFN is typically equal to 541.46 ms [2].

The considered multi-beam NTN system is based on the 5G NR technology that supports multiple scalable OFDM numerologies ( $\mu = 0$  to 4), each characterized by a different SCS ( $SCS = 15kHz$  to  $240kHz$ ) according to the following equation [3]:

$$SCS = 15kHz \times 2^\mu, \quad (4.1)$$

where  $\mu$  is the numerology index.

The NR transmission is based on the OFDM with CP-OFDM in the downlink, whereas both CP-OFDM and DFT-s-OFDM with the cyclic prefix are supported in the uplink. The NR downlink and uplink transmissions are arranged in frames, each consisting of 1 ms subframes. Every subframe has a different number of slots according to the selected numerology. The radio spectrum is managed in terms of Resource Block (RB), each of which consists of 12 consecutive and equally spaced sub-carriers. In this work, we refer to the NTN terminals interested in eMBB services; hence, we choose the numerology  $\mu = 0$  with  $SCS = 15kHz$ , which is the most suitable for eMBB applications delivered over eMBMS.

Let  $\mathcal{S}$  be the set of beams to cover a given area on Earth. We define the *Synchronized Beam Area (SBA)* as a GEO-sat coverage area where one or more MBAs could be formed. We define the *MBA* as an area corresponding to two or more adjacent beam footprints where the respective beams are synchronized in time to deliver the same content flow over the same radio resources to multiple destinations, by performing an MBSFN Beam transmission<sup>2</sup>. We denote  $\mathcal{M}$  as the set of all MBAs included within an SBA, and  $\mathcal{E}$  is the set of all eMBB content items requested in the SBA.

Let  $\mathcal{T}$  be the set of all NTN terminals, which are interested in the broadcasted eMBB contents to be served:

$$|\mathcal{T}| = \sum_{m \in \mathcal{M}} |\mathcal{T}_m|, \quad (4.2)$$

where  $\mathcal{T}_m$  is the set of NTN terminals belonging to the  $m$ -th MBA.

We denote  $\mathcal{RB}$  to be the set of available radio resources (i.e., in terms of RBs). Let  $\mathcal{RB}_m$  be the number of RBs assigned to the beams of the  $m$ -th MBA. The overall number of RBs to be allocated to the  $m$ -th MBA shall not exceed the number of available RBs:

<sup>2</sup> In this work, we define the MBSFN Beam transmission or multi-beam transmission in the MBSFN mode as a simulcast transmission technique realized by the transmission of identical NTN waveforms at the same time from multiple beams of the same NTN-platform. An MBSFN Beam Transmission from multiple beams within the MBA is regarded as a single transmission by the NTN terminal.

$$|\mathcal{RB}_m| \leq |\mathcal{RB}|, \quad \forall m \in \mathcal{M}. \quad (4.3)$$

If one or more beam footprints belong to more MBAs, the sum of the RBs assigned to the beams of those MBAs shall not exceed the number of available RBs in order to avoid inter-beam interference:

$$\sum_{m \in \mathcal{M}} |\mathcal{RB}_m| \leq |\mathcal{RB}|. \quad (4.4)$$

The aim of the proposed RRM scheme is to increase the overall ADR of the multi-beam NTN system by meeting the above constraints when performing link adaptation with a dynamic selection of the MCS level for the MBSFN Beam transmission according to the CSI feedback information sent by all the NTN terminals to the GEO-sat. By referring to an SBA as the set  $\mathcal{M}$  of MBAs, the ADR is given by:

$$\mathcal{ADR} = \sum_{m \in \mathcal{M}} \mathcal{ADR}_m, \quad (4.5)$$

where the ADR of the NTN terminals receiving the content in the  $m$ -th MBA through the MBSFN Beam transmission is represented as:

$$\mathcal{ADR}_m = \sum_{t \in \mathcal{T}_m} \text{Rate}(t) \times |\mathcal{RB}_m|, \quad \forall m \in \mathcal{M}, \quad (4.6)$$

where  $\text{Rate}(t)$  is the minimum data rate per RB related to the  $t$ -th NTN terminal with the lowest MCS out of all NTN terminals in the  $m$ -th MBA. The proposed RRM scheme targets to solve, via a heuristic approach, the following problem:

$$\arg \max_{\mathcal{RB}} \mathcal{ADR}, \quad (4.7)$$

subject to (4.2) – (4.6).

### 4.3.2 Channel Model

In this work, we consider the Land Mobile Satellite (LMS) channel represented according to the Pèrez-Fontán model [175]. A three-state first-order Markov chain describes three propagation conditions that are LoS, moderate shadowing, and deep shadowing. The Markov chain is defined by the transition probability matrix  $\mathbf{P}$  and

**Table 4.1.** Loo distribution parameters for each modeled environment at an elevation angle of  $40^\circ$ .

<i>Environment</i>	State 1: LoS			State 2: Moderate Shadowing			State 3: Deep Shadowing		
	$\alpha$ (dB)	$\psi$ (dB)	$MP$ (dB)	$\alpha$ (dB)	$\psi$ (dB)	$MP$ (dB)	$\alpha$ (dB)	$\psi$ (dB)	$MP$ (dB)
Open	0.1	0.37	-22.0	-1.0	0.5	-22.0	-2.25	0.13	-21.2
Suburban	-1.0	0.5	-13.0	-3.7	0.98	-12.2	-15.0	5.9	-13.0
Urban	-0.3	0.73	-15.9	-8.0	4.5	-19.2	-24.4	4.5	-19.0
Intermediate Tree Shadowed	-0.4	1.5	-13.2	-8.2	3.9	-12.7	-17.0	3.14	-10.0
Heavy Tree Shadowed	-	-	-	-10.1	2.25	-10.0	-19.0	4.0	-10.0

**Table 4.2.** Markov Chain Matrices  $\mathbf{P}$  and state probability vectors  $\mathbf{w}$  for each modeled environment at an elevation angle of  $40^\circ$  (University of Bradford experimental campaign).

<b>Environment</b>	<b>w</b>	<b>P</b>
Open	0.5	0.9530 0.0431 0.0039
	0.375	0.0515 0.9347 0.0138
	0.125	0.0334 0.0238 0.9428
Suburban	0.4545	0.8177 0.1715 0.0108
	0.4545	0.1544 0.7997 0.0459
	0.091	0.1400 0.1433 0.7167
Urban	0.4	0.8628 0.0737 0.0635
	0.2667	0.1247 0.8214 0.0539
	0.3333	0.0648 0.0546 0.8806
Intermediate Tree Shadowed	0.3929	0.7193 0.1865 0.0942
	0.3571	0.1848 0.7269 0.0883
	0.25	0.1771 0.0971 0.7258
Heavy Tree Shadowed	0.0	0.7792 0.0452 0.1756
	0.5	0 0.9259 0.0741
	0.5	0 0.0741 0.9259

the state probability vector  $\mathbf{w}$ .

In each state, signal amplitude variations due to shadowing and multipath phenomena follow three different parameters (i.e.,  $\alpha, \Psi, MP$ ) of the Loo probability density function [176].

Further, this model captures the satellite channel at more elevation angles and in other environments. In this work, we consider an elevation angle of  $40^\circ$ , while five environment types (i.e. Open, Suburban, Urban, Intermediate Tree Shadowed, and Heavy Tree Shadowed) are modeled each by a dedicated Markov matrix, a specific state probability vector, and a particular set of Loo distribution parameters. Below, we consider the Loo distribution parameters collected in Table 4.1; the Markov matrix and the probability vector are demonstrated in Table 4.2.

## 4.4 Proposed SF-MBT Scheme

### 4.4.1 General Description

The proposed SF-MBT scheme aims to efficiently allocate the radio resources in order to provide higher ADR in a multi-beam NTN system with respect to the frequency re-use schemes. To achieve this goal, our SF-MBT algorithm exploits the concept of MBSFN among the beams of the same GEO-satellite by synchronizing (in time) the transmission over the beams when delivering the same eMBB service by exploiting the same set of RBs. The parameters of the MBSFN beam transmission are set according to the lowest MCS (i.e., the most robust modulation) supported by all of the NTN terminals interested in a given eMBB content. Figure 4.2 introduces the SF-MBT algorithm in question by means of a flowchart.

The working principle of the proposed scheme is to group the beams belonging to the GEO-satellite SBA in several MBAs on a per-content basis, thus taking into account the interests of NTN terminals. When a beam belongs exclusively to one MBA or an *independent MBA*, all the NTN terminals within the coverage of that beam are interested in the same content, whereas when a beam belongs to two or more MBAs, it shall deliver two or more items of content. For the latter context, we define the *overlapping MBAs* as two or more MBAs sharing at least one beam. In the case of overlapping MBAs, the SF-MBT scheme performs radio resource allocation across the involved MBAs to avoid inter-beam interference. Further, the SF-MBT scheme improves the system ADR by meeting the constraint to serve all of the interested NTN terminals.

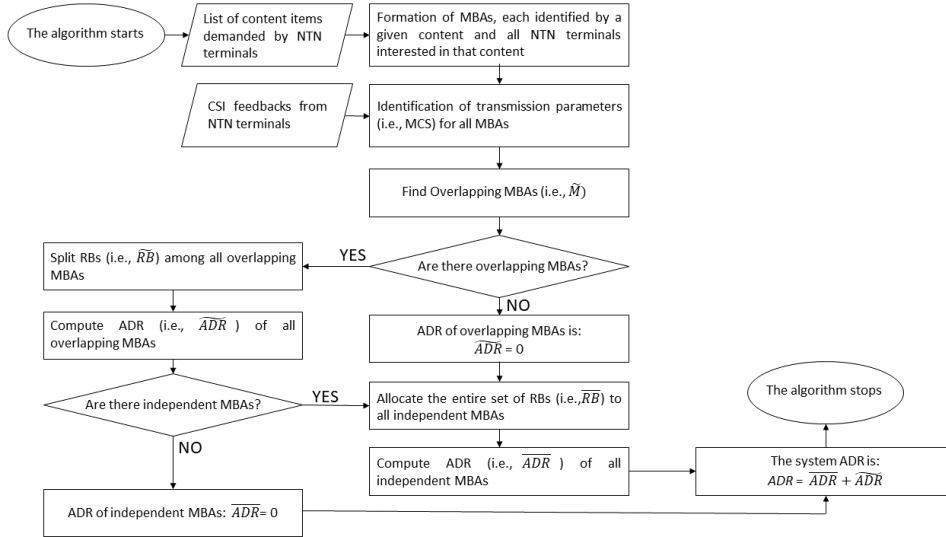

Fig. 4.2. Flowchart of our SF-MBT algorithm.

#### 4.4.2 Step-by-Step Implementation

Algorithm 1 reports the pseudo-code that describes the working logic of the proposed SF-MBT scheme. Table 4.3 lists the main notation employed by the pseudo-code.

Table 4.3. Notation in Use

$\mathcal{I}$	set of all beams of a GEO-sat
$\mathcal{M}$	set of all MBAs
$\mathcal{T}$	set of NTN terminals requiring broadcast service
$\mathcal{E}$	set of all eMBB content items requested in the SBA
$\mathcal{I}^*$	set of beams transmitting a given content $e$
$\mathcal{M}^*$	set of MBAs where delivering a given content $e$
$\tilde{\mathcal{M}}$	set of MBAs having one or more beams in common
$\bar{\mathcal{M}}$	set of MBAs with no beams in common
$\mathcal{RB}$	set of available radio resources
$\tilde{\mathcal{R}}\mathcal{B}$	set of RBs for MBAs with beams in common
$\bar{\mathcal{R}}\mathcal{B}$	set of RBs for MBAs without common beams
$\mathcal{ADR}$	ADR of the multi-beam NTN system
$\tilde{\mathcal{ADR}}$	ADR of MBAs with at least one common beam
$\bar{\mathcal{ADR}}$	ADR of all MBAs without common beams
$ \cdot $	cardinality of a set

The algorithm begins by receiving at the input the set  $\mathcal{E}$  of all the eMBB content items, the set  $\mathcal{I}$  of GEO-satellite beams, and the set  $\mathcal{T}$  of all the NTN terminals interested in at least one eMBB content item (line 1).

---

**Algorithm 1** Single-Frequency Multi-Beam Transmission
 

---

```

1: Input:  $\mathcal{E}, \mathcal{I}, \mathcal{T}$ 
2:  $\mathcal{M} = \emptyset$ ;
3: for  $e \in \mathcal{E}$  do
4:    $\mathcal{I}^* = \emptyset$ ;  $\triangleright$  set of beams transmitting  $e$ -th content
5:    $\mathcal{M}^* = \emptyset$ ;  $\triangleright$  set of MBAs where delivering  $e$ -th content
6:   for  $i \in \mathcal{I}$  do
7:     if (count NTN terminals interested in  $e$ -th content)  $\geq 1$  then
8:       add  $i$  in  $\mathcal{I}^*$ ;
9:     end if
10:  end for
11:   $\mathcal{M}^* = \text{FindAdjacentBeams}(\mathcal{I}^*)$ ;
12:  for  $m^* \in \mathcal{M}^*$  do
13:    add  $m^*$  in  $\mathcal{M}$ ;
14:  end for
15: end for
16:  $\tilde{\mathcal{M}} = \emptyset$ ;  $\triangleright$  set of MBAs having one or more beams in common
17:  $\tilde{\mathcal{R}}\mathcal{B} = \emptyset$ ;  $\triangleright$  set of RBs allocated to MBA in  $\tilde{\mathcal{M}}$ 
18:  $\tilde{\mathcal{A}}\mathcal{D}\mathcal{R} = 0$ ;  $\triangleright$  ADR related to  $\tilde{\mathcal{M}}$ 
19:  $\tilde{\mathcal{M}} = \text{FindOverlappingMBA}(\mathcal{I}, \mathcal{M})$ ;
20: if  $\text{IsEmpty}(\tilde{\mathcal{M}}) == \text{TRUE}$  then
21:    $\mathcal{R}\mathcal{B} = \text{AllocateAllRB}(\mathcal{M})$ ;
22:    $\mathcal{A}\mathcal{D}\mathcal{R} = \text{ComputeADR}(\mathcal{M}, \mathcal{R}\mathcal{B})$ ;
23: else if  $\text{IsEmpty}(\tilde{\mathcal{M}}) == \text{FALSE}$  then
24:    $\bar{\mathcal{M}} = \emptyset$ ;  $\triangleright$  set of MBAs with no beam in common
25:    $\bar{\mathcal{R}}\mathcal{B} = \emptyset$ ;  $\triangleright$  set of RBs allocated to MBA in  $\bar{\mathcal{M}}$ 
26:    $\bar{\mathcal{A}}\mathcal{D}\mathcal{R} = 0$ ;  $\triangleright$  ADR related to  $\bar{\mathcal{M}}$ 
27:    $\bar{\mathcal{M}} = \mathcal{M} \cap \tilde{\mathcal{M}}$ ;
28:    $\bar{\mathcal{R}}\mathcal{B} = \text{SplitRB}(\bar{\mathcal{M}})$ ;
29:    $\bar{\mathcal{A}}\mathcal{D}\mathcal{R} = \text{ComputeADR}(\bar{\mathcal{M}}, \bar{\mathcal{R}}\mathcal{B})$ ;
30:   if  $\text{IsEmpty}(\bar{\mathcal{M}}) == \text{FALSE}$  then
31:      $\mathcal{R}\mathcal{B} = \text{AllocateAllRB}(\bar{\mathcal{M}})$ ;
32:      $\mathcal{A}\mathcal{D}\mathcal{R} = \text{ComputeADR}(\bar{\mathcal{M}}, \mathcal{R}\mathcal{B})$ ;
33:      $\mathcal{R}\mathcal{B} = \bar{\mathcal{R}}\mathcal{B} \cup \mathcal{R}\mathcal{B}$ ;
34:      $\mathcal{A}\mathcal{D}\mathcal{R} = \bar{\mathcal{A}}\mathcal{D}\mathcal{R} + \mathcal{A}\mathcal{D}\mathcal{R}$ ;

```

---

---

```

35:   else if isEmpty( $\tilde{\mathcal{M}}$ )==TRUE then
36:      $\mathcal{RB} = \tilde{\mathcal{RB}}$ ;
37:      $\mathcal{ADR} = \tilde{\mathcal{ADR}}$ ;
38:   end if
39: end if
40: Output:  $\mathcal{M}, \mathcal{RB}, \mathcal{ADR}$ 

```

---

The first step is to verify, for each GEO-satellite beam  $i$ , if there is at least one NTN terminal interested in the  $e$ -th content item in order to be considered a part of the same set  $\mathcal{S}^*$  of beams, which could join the same MBA after satisfying the adjacency constraint (lines 2–15).

Once the set  $\mathcal{M}$  of all the MBAs delivering different eMBB content items is defined, the algorithm proceeds by identifying all of the overlapping MBAs where shared beams shall broadcast more eMBB services (lines 16–19). This step is essential to initiate an efficient radio resource allocation procedure for avoiding inter-beam interference. Indeed, if there are only independent MBAs (line 20) and, hence, no beam is shared among the MBAs, all the available radio resources are re-used in each MBA (line 21) without entailing any kind of interference among the MBAs. The related ADR is then computed (line 22).

Otherwise, in the case of overlapping MBAs (line 23), the available radio resources are split among the overlapping MBAs to avoid inter-beam (among the beams belonging to the overlapping MBAs) and intra-beam (within the beam where more than one content item is delivered) interference due to the transmission of different content flows (line 28). The related ADR is then computed (line 29). Further, the algorithm verifies whether – among all the MBAs – there are also independent MBAs that deliver only one content item (lines 24–27).

If such independent MBAs exist (line 30), all the radio resources are re-used among all the independent MBAs for the eMBB provisioning (line 31) and the related ADR is computed (line 32). In this case, the final set of RBs and the overall system ADR are, respectively, the union of the sets of RBs and the sum of the two ADR components related to the overlapping MBAs and the independent MBAs (lines 33–34). Otherwise, if no independent MBAs are identified (line 35), the final set of RBs and the system ADR are, respectively, the set of RBs and the ADR related to the overlapping MBAs only (lines 36–37). Finally, the algorithm terminates by providing at the output the set  $\mathcal{M}$  of all MBAs, the set  $\mathcal{RB}$  of the allocated RBs, and the system  $\mathcal{ADR}$  (line 40).

### 4.4.3 Complexity Analysis

A detailed complexity analysis of the proposed SF-MBT scheme is provided below.

In lines 1–15, the complexity is:

$$O(|\mathcal{E}| \cdot (|\mathcal{S}| \cdot |\mathcal{T}| + |\mathcal{S}|^2 + |\mathcal{M}|)), \quad (4.8)$$

where:

- $O(|\mathcal{E}|)$  is the complexity due to the “for” cycle over the eMBB content items (line 3);
- $O(|\mathcal{S}| \cdot |\mathcal{T}|)$  is the complexity of verifying (for all beams) how many NTN terminals are interested in a given service (lines 6–10);
- $O(|\mathcal{S}|^2)$  is the complexity due to the verification of the adjacency constraint among the beams (line 11);
- $O(|\mathcal{M}|)$  is the complexity due to the insertion of all the MBAs wherein a given eMBB service is delivered to the final set of MBAs (line 12–14).

In line 19, the complexity to find all the overlapping MBAs is  $O(|\mathcal{S}| \cdot |\mathcal{M}|)$ . It depends on the search of common beams in all the created MBAs. In lines 20–39, the complexity is  $O(|\mathcal{M}|)$  due to the allocation of radio resources and the computation of the ADR, which is because the check as to whether the overlapping MBAs exist (lines 20 and 23) and the check as to whether at least one independent MBA exists (lines 30 and 33) have constant complexity.

The implementation of the SF-MBT algorithm has the following polynomial complexity:

$$O(|\mathcal{E}| \cdot (|\mathcal{S}| \cdot |\mathcal{T}| + |\mathcal{S}|^2 + |\mathcal{M}|) + |\mathcal{E}| \cdot |\mathcal{S}| \cdot |\mathcal{M}|). \quad (4.9)$$

The proposed SF-MBT algorithm is, however, more complex than the current re-use based schemes, whose complexity is:

$$O(|\mathcal{S}| \cdot |\mathcal{E}| \cdot |\mathcal{T}|). \quad (4.10)$$

However, the SF-MBT complexity is reasonable for realistic scenarios in a multi-beam NTN system. Indeed, the proposed algorithm is executable in feasible runtime owing to the high performing GEO-gNB of the next-generation technology. Further, to

support the SF-MBT in 5G NR multi-beam NTN systems, the 5G NR technology may require certain adjustments. First, multi-beam transmission synchronization at the network side and signal combination at the receiver should be configured by choosing the appropriate cyclic prefix to compensate for the delay spread.

Therefore, signals belonging to different beams are regarded as multi-path components of the same signal and are constructively combined at the NTN terminal. Second, an air interface should be designed to support non-terrestrial broadcasting/-multicasting in multi-beam NTN systems based on the 5G NR technology. Finally, additional features, modifications, and solutions to support 5G NR applications for NTN are planned to be defined in the subsequent 3GPP Release 17.

## 4.5 Performance Evaluation

### 4.5.1 Simulation Model

A simulation campaign has been conducted by using a dedicated simulator specifically developed, through the MATLAB tool, for the SF-MBT over 5G NR multi-beam NTN systems. Further, it has been calibrated by following the guidelines of the 3GPP technical report [2]. Each simulation run has been repeated multiple times to attain 95% confidence intervals.

The proposed RRM scheme comprises two-way communications using multi-beam transmissions operating in the single frequency mode. We assume that two eMBB flows are requested by the NTN terminals. Since the overlapping MBAs (i.e., MBAs that share at least one beam where delivering both content items) may be formed, the radio resources are split to avoid inter-beam interference and are allocated according to a fair policy (i.e., the volume of available radio resources is equally divided between the two content flows).

We consider the simulation time of 1000 ms, which corresponds to 100 frames. We further assume that the channel conditions of the NTN terminals vary every TTI and that the GEO-gNB schedules the transmissions towards the NTN terminals during every subframe that lasts 1 ms. We also consider  $\mathcal{S} = 71$  to be the number of beams required to cover Europe [73]. More information about the modeling parameters is available in Table 4.4.

We assess the following five environment types: Heavy Tree Shadowed, Intermediate Tree Shadowed, Open, Suburban, and Urban. For all of them, we study the performance in two different modeling cases:

**Table 4.4.** Main Modeling Parameters [2], [3].

PARAMETER	VALUE
NTN architecture option	GEO satellite equipped with transparent payload
GEO altitude	35786 km
GEO EIRP density	53.5 dBW/MHz
GEO Tx max gain	45.5 dBi
Beam footprint size	450 km (diameter)
Beam footprint type	Fixed
Beam footprint layout	Hexagonal
Number of beams	71 to cover all of Europe [73]
NTN terminal type	Handheld
NTN terminal distribution	100% outdoor
NTN terminal speed	3 kmph
NTN terminal antenna type	Omnidirectional with linear polarization
NTN terminal antenna gain	0 dBi
NTN terminal noise figure	9 dB
NTN terminal Tx power	23 dBm
Carrier frequency	S-band (i.e., 2 GHz)
Maximum bandwidth per beam	30 MHz for S-band
Numerology	0
Sub-carrier spacing	15 kHz
Transmission time interval	1 ms
Free-space pathloss	$L = 32.45 + 20 \log_{10}(f_c) + 20 \log_{10}(d)$ where: $f_c$ is the carrier frequency; $d$ is the distance between the GEO and the NTN terminal

- **Case A**, where the channel bandwidth is fixed to 30 MHz<sup>3</sup> (i.e., 160 RBs are available [20]), and the number of NTN terminals per beam varies from 100 to 1000;
- **Case B**, where the channel bandwidth varies from 5 to 30 MHz (that corresponds to 25, 52, 79, 106, 133, and 160 available RBs [20]), and the number of NTN terminals per beam is set to 1000.

<sup>3</sup> The maximum bandwidth allowed per beam is 30 MHz for S-band [2]

The performance of the proposed SF-MBT scheme has been compared against that for the multi-beam NTN system based on a four-color frequency re-use scheme ( $\rho = 2$ ) [2] and the multi-beam NTN system based on a three-color frequency re-use scheme ( $\rho = 3$ ) [2]. The following metrics of interest have been evaluated:

- **Mean Throughput** is the average data rate experienced by the NTN terminals.
- **ADR** is the sum of all the throughputs experienced by the NTN terminals.
- **System Spectral Efficiency** is the ratio between the number of bits received by the NTN terminals and the channel bandwidth of the reference system. This parameter indicates how efficient the radio resource management policy is since it provides information on the amount of system data over the channel bandwidth.

#### 4.5.2 Analysis of Results

The selected performance results are grouped and analyzed according to the input parameters (i.e., case A and case B). Note that the curve for the SF-MBT scheme has been marked by a solid line with “\*”, the curve for the four-color frequency reuse scheme has been marked by a dashed line with “o”, while the curve for the three-color frequency reuse scheme has been marked by a dashed line with “x”.

##### Performance Results in Case A

Figs. 4.3, 4.4, and 4.5 illustrate the ADR, mean throughput, and system spectral efficiency, respectively, for the three schemes in question under a varying number of NTN terminals per beam. It can be noted that – in all five environments – the proposed SF-MBT scheme provides the best system-wide results as compared to both four-color and three-color frequency re-use approaches. In more detail, the ADR follows a growing trend for an increased number of NTN terminals in the system. This behavior is due to the additive nature of the parameter since the ADR is computed as the sum of the data rates for all NTN terminals.

The ADR achieved by the proposed SF-MBT scheme ranges from 68 to 343 Gbps in most environments except for the Open case, where a high-performing multicast link is established; hence, the ADR achieves up to 4560 Gbps in the case of 1000 NTN terminals per beam. When considering a given MBA, it is worth noting that the choice of the SF-MBT parameters is affected by the worst CSI perceived by the NTN terminals in that area; hence, the most robust modulation is selected. In contrast, the transmission parameters for both four-color and three-color frequency re-use schemes are chosen on a per-beam basis.

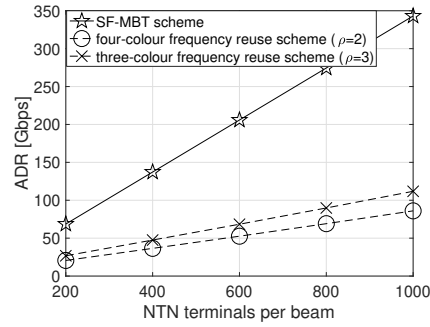

(a) Heavy Tree Shadowed

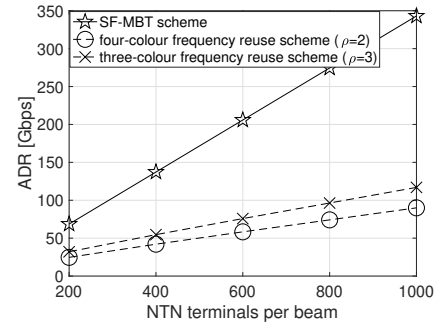

(b) Intermediate Tree Shadowed

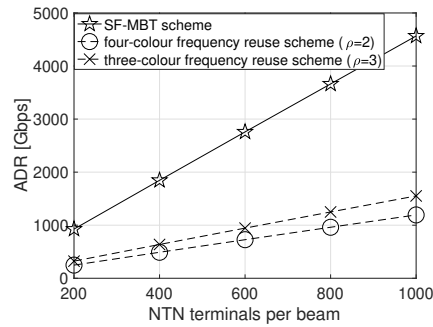

(c) Open

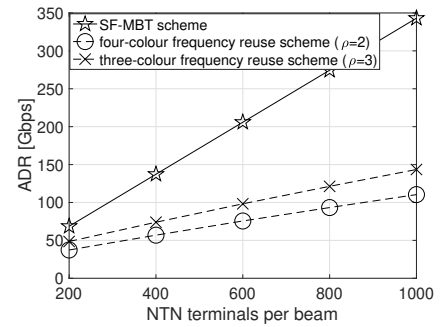

(d) Suburban

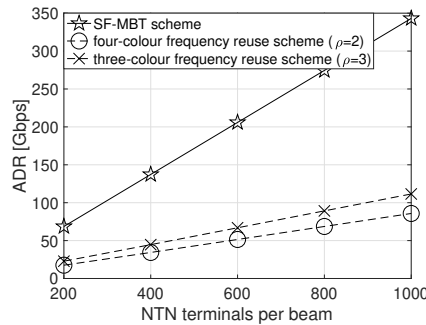

(e) Urban

**Fig. 4.3.** ADR for SF-MBT, four-color, and three-color frequency re-use schemes with a varying number of NTN terminals per beam.

Therefore, the SF-MBT transmission may depend already on a single NTN terminal with poor channel conditions, whereas the frequency re-use based transmission varies beam by beam. In the latter case, the ADR (Fig. 4.3) is likely to differ from environment to environment for the two considered frequency re-use approaches. Indeed, with an increased number of NTN terminals in the system the mean throughput decreases since the probability to find at least one NTN terminal with worse channel conditions in each beam grows.

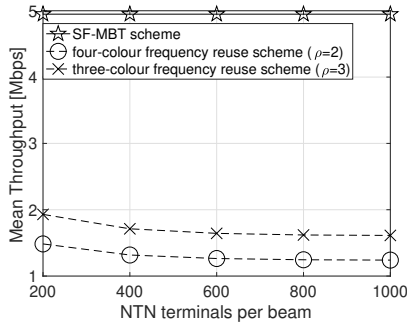

(a) Heavy Tree Shadowed

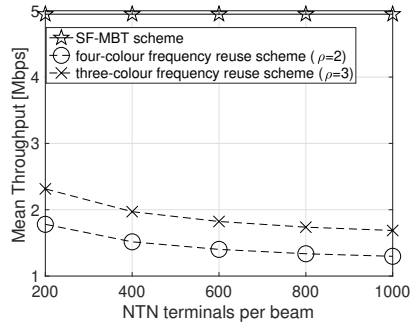

(b) Intermediate Tree Shadowed

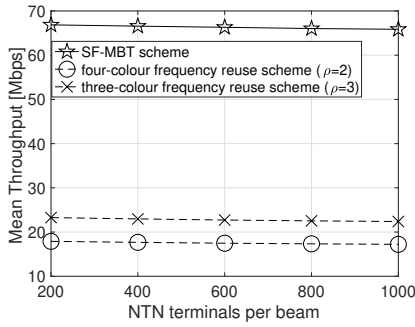

(c) Open

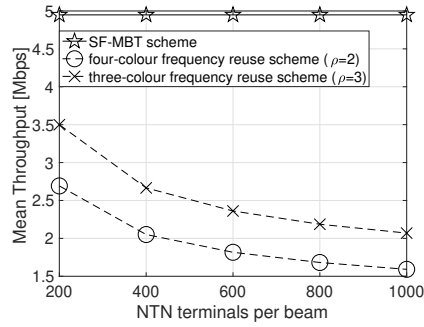

(d) Suburban

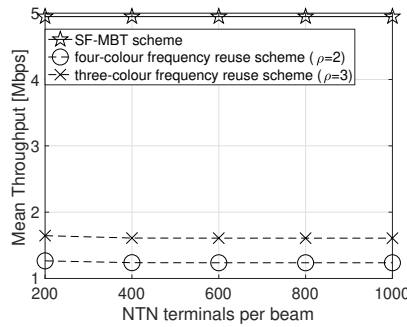

(e) Urban

**Fig. 4.4.** Mean throughput for SF-MBT, four-color, and three-color frequency re-use schemes with a varying number of NTN terminals per beam.

However, the mean throughput (Fig. 4.4) remains constant (i.e., 68 Mbps in the Open environment and about 5 Mbps in other environments) for the SF-MBT scheme as the number of NTN terminals grows since only one NTN terminal with adverse channel conditions in the NTN system suffices to yield the most robust modulation for transmission. In Fig. 4.5, the system spectral efficiency provides information on the amount of data delivered per second over a given channel bandwidth. It follows the same trend as the mean throughput since the channel bandwidth is fixed at 30 MHz for

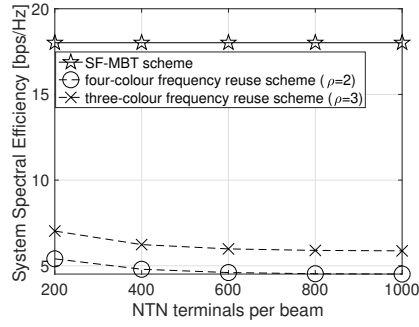

(a) Heavy Tree Shadowed

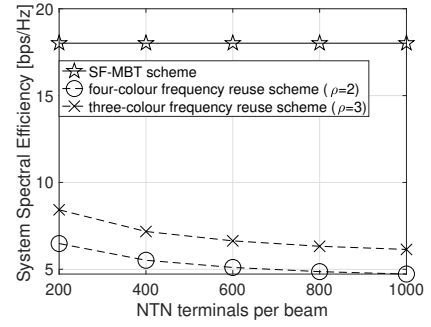

(b) Intermediate Tree Shadowed

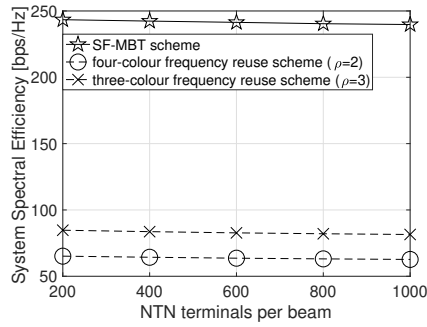

(c) Open

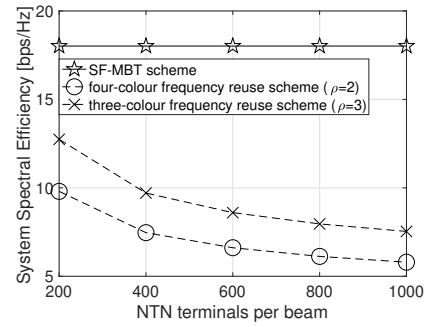

(d) Suburban

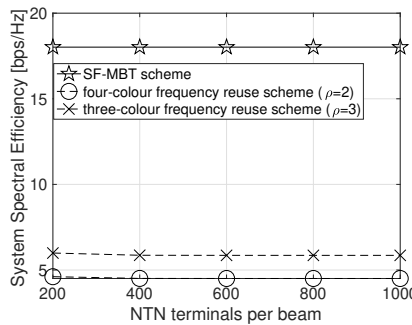

(e) Urban

**Fig. 4.5.** System spectral efficiency for SF-MBT, four-color, and three-color frequency re-use schemes with a varying number of NTN terminals per beam.

the case A. The proposed scheme offers better utilization of the radio spectrum than the frequency re-use based approaches by attaining higher values of system spectral efficiency in all the considered environments.

**Performance Results in Case B**

Fig. 4.6, 4.7, and 4.8 demonstrate the ADR, mean throughput, and system spectral efficiency, respectively, for the three schemes in question under varying channel band-

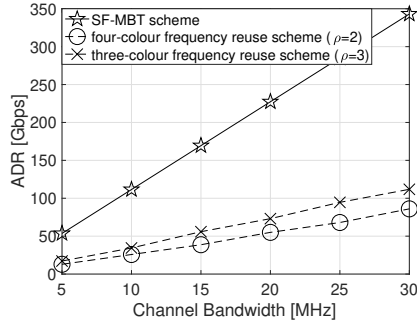

(a) Heavy Tree Shadowed

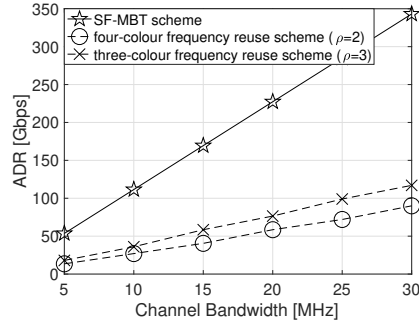

(b) Intermediate Tree Shadowed

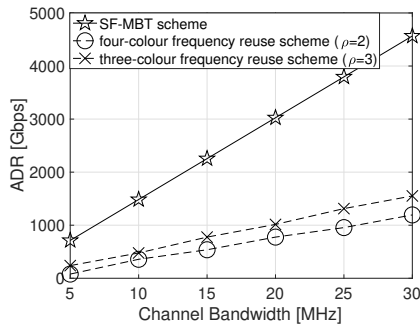

(c) Open

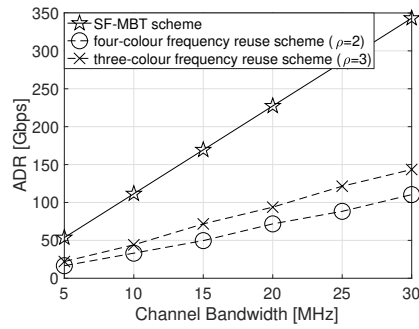

(d) Suburban

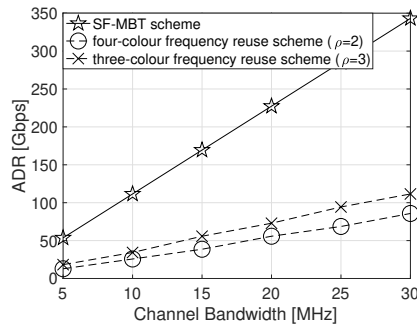

(e) Urban

**Fig. 4.6.** ADR for SF-MBT, four-color, and three-color frequency re-use schemes with a varying channel bandwidth.

width. In all the environments, the proposed SF-MBT scheme reaches the highest values for all the metrics of interest with respect to the considered frequency re-use based approaches. Both ADR and mean throughput follow a growing trend for all the three schemes because an increased channel bandwidth (i.e., more radio resources) is considered. For the proposed SF-MBT scheme, the ADR (Fig. 4.6) ranges from 713 to 4560 Gbps in the Open environment and from 53 to 343 Gbps in other environments. Similar ADR values are achieved in Heavy Tree Shadowed, Intermediate Tree

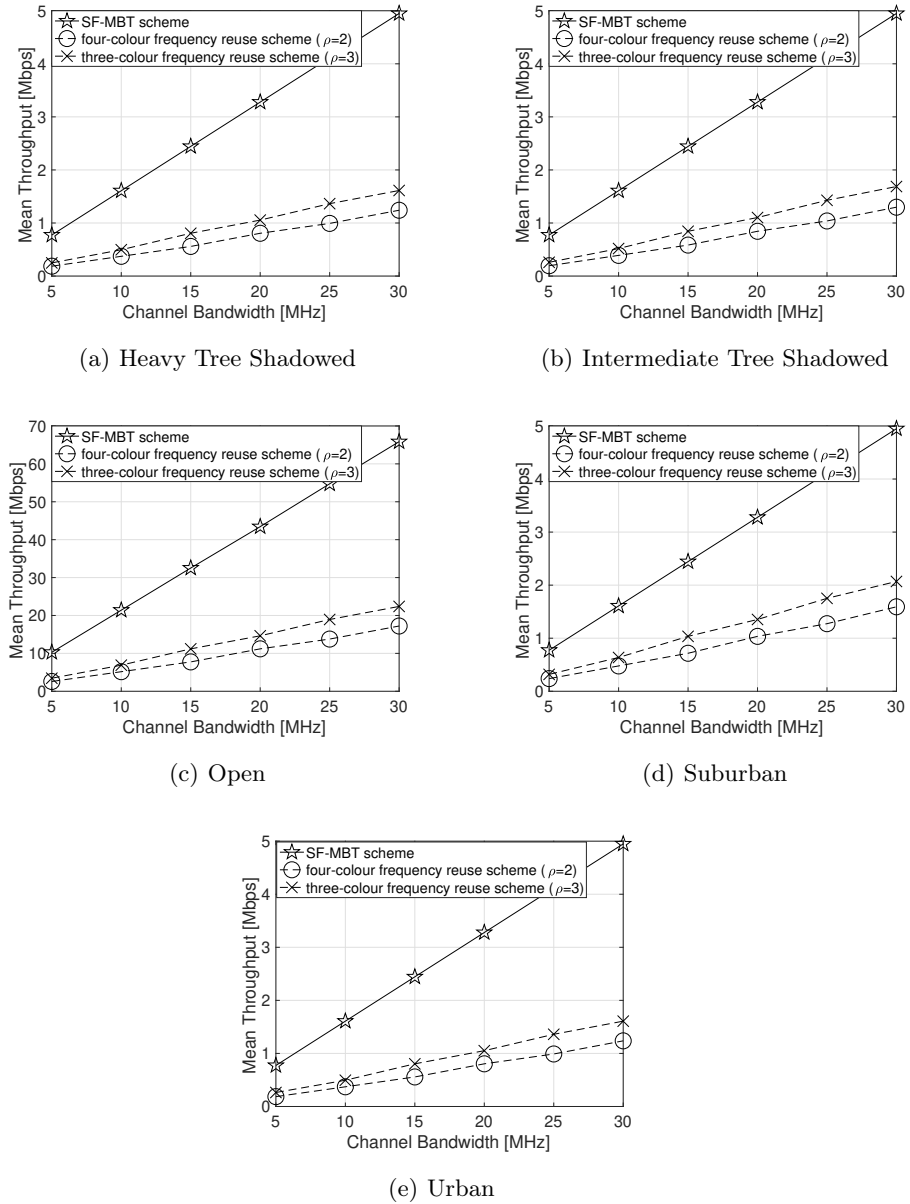

**Fig. 4.7.** Mean throughput for SF-MBT, four-color, and three-color frequency re-use schemes with a varying channel bandwidth.

Shadowed, Urban, and Suburban environments due to a similar mean throughput performance.

The throughput depends on the modulation selected to allow all of the interested NTN terminals to decode the delivered data. In such environments, NTN terminals are likely to experience a varying channel, whose quality fluctuations can be irregular over time. Conversely, in the Open environment, the channel conditions of NTN terminals are excellent and do not vary drastically, which yields higher system-wide performance.

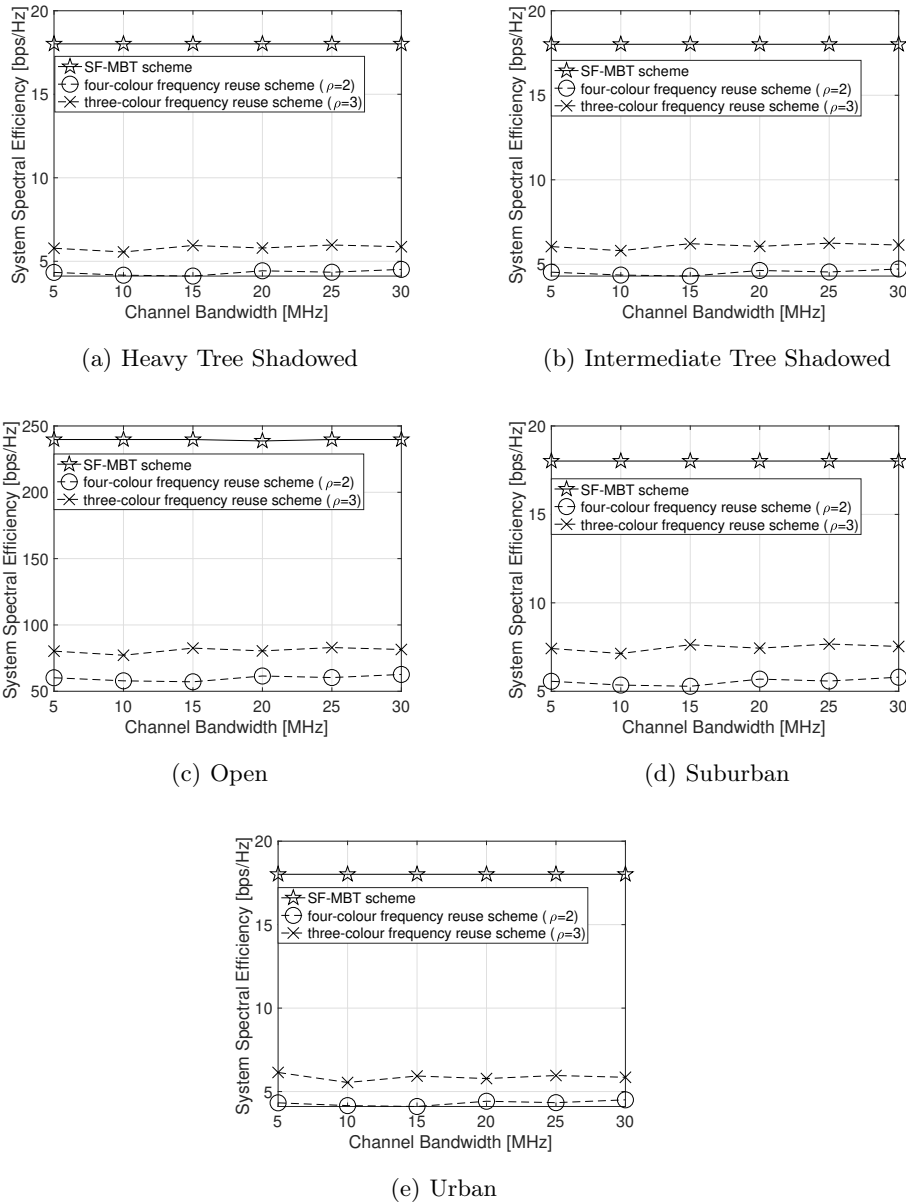

**Fig. 4.8.** System spectral efficiency for SF-MBT, four-color, and three-color frequency re-use schemes with a varying channel bandwidth.

As shown in Fig. 4.7, the mean throughput ranges from 10 to 67 Mbps in the Open environment while in other cases it spans from 791 kbps to 5 Mbps. Finally, in Fig. 4.8, the system spectral efficiency follows a near-constant trend for all the approaches in all the environments. However, the proposed SF-MBT scheme exploits the radio spectrum better than the counterpart frequency re-use options.

## 4.6 Conclusion

In this chapter, we proposed the SF-MBT scheme for broadcasting eMBB services through synchronous beam transmissions in 5G NR multi-beam NTN systems. Our SF-MBT approach expects that the beams of the same satellite are grouped into different MBA, wherein all of the beams are synchronized in time to perform a simultaneous transmission of a certain service over the same radio resources. The MBAs can be *independent* or *overlapping*: an independent MBA comprises of beams wherein only one content item is delivered, whereas overlapping MBAs include at least one beam belonging to more MBAs, each delivering different content items.

Further, our SF-MBT scheme splits the radio resources among the overlapping MBAs to avoid interference during the data delivery, whereas all of the radio resources are allocated to independent MBAs. The proposed solution aims to overcome the limitations of the currently implemented policies, where different frequencies are re-used across the beams of the same satellite to avoid inter-beam interference. Finally, the effectiveness of the developed scheme is confirmed via extensive simulations that indicate its highest performance as compared to alternative frequency re-use approaches. Future work needs to address new radio resource management strategies for handling varying traffic demands characterized by different quality requirements.



## Resource Allocation for eMBB Service Delivery in Integrated 5G NR Cooperative Terrestrial-Satellite Networks

*The NTN based on the emerging 5G NR technology represents an effective solution to complement terrestrial networks in providing services with anywhere and anytime connections and to increase network scalability by delivering multicast/broadcast services to groups of NTN terminals through PtM transmissions. However, current satellite systems operating at different orbits remain isolated and fail to express their true potential if not designed to be interoperable with ground networks. In the light of effectively integrating existing 5G networks into a unified system, we propose a cooperative radio resource management scheme that enhances the performance of an integrated TN-NTN system based on the emerging 5G NR technology. It leverages the principles of multicast subgrouping techniques to determine which users will get connected to either terrestrial base station (i.e., gNB) or NTN cell (i.e., NTN-gNB), and properly allocate resources to improve the overall network throughput. Simulation results show the effectiveness of the proposed solution.*

### 5.1 Introduction

To realize the promise of performance improvement, current 5G NR systems are ready to answer the ever-growing demand for innovative services that require wide bandwidth and are consumed by an increasing number of smart devices.

The NTN based on the emerging 5G NR technology represents an effective solution to complement terrestrial networks in providing services with anywhere and anytime connections by ensuring the availability of services in wide areas. Furthermore, the 5G NTN may increase network scalability by delivering multicast/broadcast services to groups of NTN terminals through PtM transmissions [3].

As defined by 3GPP, an NTN is a network where NTN platforms, grouped into spaceborne (i.e., GEO, MEO, and LEO satellites) and airborne (i.e., UAS and HAPS) vehicles, act either as a relay node or as a flying base station. Following the

outcome of the preceding study items [2], the standardization of NR connectivity over satellites is currently underway as part of 3GPP Release 17, which will also introduce multicast/broadcast transmissions for the 5G NR access technology.

The rapid increase of satellites orbiting Earth confirms the growing interest in NTN. However, various space systems on different orbits remain isolated and disconnected from the ground networks. Therefore, integrating all existing networks in air, space, and on-ground into a unified system [9] will be essential for current 5G and next-to-come 6G networks.

In this vein, this chapter proposes a novel RRM scheme that enhances the performance of an integrated TN-NTN system based on the emerging 5G NR technology. It exploits the principles of multicast subgrouping technique to group users under the coverage of both terrestrial cells (i.e., gNB) and NTN cells (i.e., NTN-gNB), and properly allocate resources to improve the overall network throughput. The main objective of the proposed solution is to mitigate the user (i.e., UE) ping-pong effect between the gNB and the NTN-gNB, increase the robustness to continuous handovers, and improve the quality of service perceived by UEs deployed at cell-edges (i.e., boost the perceived data rate). To the best of our knowledge, such a study of 5G NR technology supported by integrated TN-NTN systems has not conducted before.

The chapter is organized as follows. Main related works are summarized in Section 5.2. The 5G NR TN-NTN system model is described in Section 5.3, whereas the proposed cooperative TN-NTN approach is presented in Section 5.4. Section 5.5 shows achieved system-level performance results. Conclusions are drawn in Section 5.6.

## 5.2 Related Works

One of the main issues of multicast transmissions is the design of AMC procedures for the setting of transmission parameters on a per-group basis (i.e., the service is provided with the most robust modulation supported by all the interested users).

The main AMC approaches proposed in the literature for terrestrial and satellite networks are described below.

The conservative approach or CMS [177] [168] sets up the lowest MCS associated to the most robust modulation supported by the target users, thus offering fairness but with low system spectral efficiency. The opportunistic approach, also known as the OMS for terrestrial networks [178] and MLA for NTN [167], schedules only a portion of the multicast group per time slot in order to optimize a given objective function (i.e., maximize the throughput).

The Multicast Subgrouping (MS) [66] serves in each time slot all the users of the initial multicast group, organized into subgroups based on the similarity of channel conditions. The concept of subgrouping is also exploited for MBSFN Area formation in [179]. In [180], D2D communications are used to improve the performance of the MBSFN transmission, which has been introduced also for NTN systems in [117].

All the above-described solutions separately address either NTN or terrestrial networks, while only a few works consider multicast subgrouping in integrated terrestrial-NTN systems.

In [181], the subgrouping approach allows for handling the differences of channel conditions in integrated terrestrial-satellite networks. First, the satellite exploits an opportunistic approach to deliver the content to a set of users on the ground. Afterward, the terrestrial base stations complete transmission by serving users who have not received data previously from the satellite. In [182], cooperative terrestrial-satellite transmissions exploit the beamforming and the frequency re-use to reduce resource consumption when the satellite and terrestrial base stations cooperatively deliver services to ground users grouped according to the desired contents. Instead, in [183] the combination of multigroup pre-coding and resource allocation aims at creating multiple groups of users to be served by either terrestrial base stations or satellites at different time slots to reduce interference while re-using the same frequency.

5G NR technology leads to new challenges in radio spectrum management. Therefore, investigating new RRM techniques is one of the major open issues of 5G NR-enabled NTN systems [184].

### 5.3 5G NR TN-NTN System Model

We refer to the integrated TN-NTN radio access architecture depicted in Figure 5.1 that is exploited to deliver multicast services. The ground terminals hereinafter referred to as TN-NTN terminals, are connected in dual-mode to both NTN-gNB and gNB through the NR-Uu radio interface. The gNB is directly connected to the 5G Core Network (5GC), whereas the NTN-gNB through the NTN Gateway.

The reference NTN-gNB is a GEO satellite equipped with a regenerative payload [2] operating in the S-band frequency (i.e., 2 GHz). The NTN-gNB and the gNB are responsible for RRM adapted to network topology [3]. Link adaptation procedures are implemented by the gNB in terrestrial networks, by the NTN gateway (i.e., transparent NTN) or on-board NTN-gNB (i.e., regenerative NTN) in NTN systems. After collecting the CSI feedbacks from TN-NTN terminals, the NTN-gNB and the gNB cooperatively

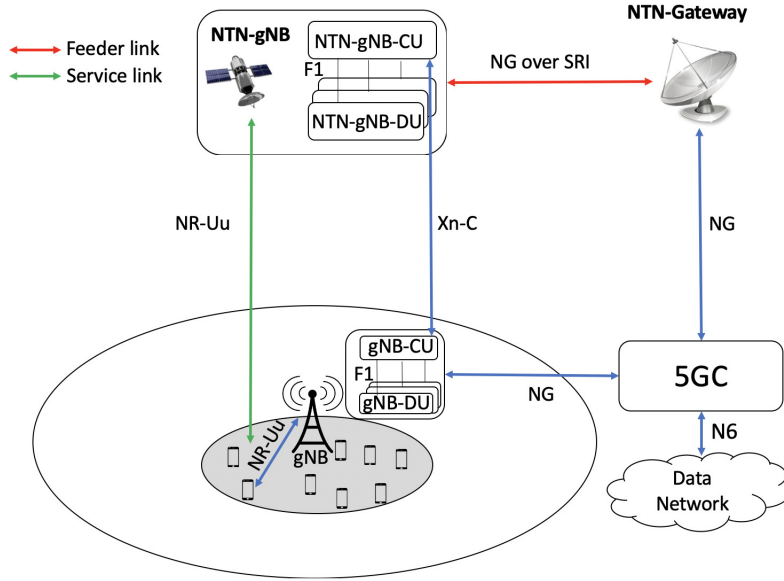

**Fig. 5.1.** Reference architecture for integrated TN-NTN networks.

allocate the radio resources by determining the subsets of users that will receive the required content by either the NTN-gNB or the gNB, and the MCS values selected for both transmissions.

The NTN channel is modeled according to the Pérez-Fontán model [175]. LoS, moderate shadowing, and deep shadowing are the three propagation conditions described by a three-state first-order Markov chain, which is defined by the transition probability matrix  $\mathbf{P}$  and the state probability vector  $\mathbf{w}$  (University of Bradford experimental campaign). In each state, three different parameters (i.e.,  $\alpha, \Psi, MP$ ) of the Loo probability density function [176] model signal amplitude variations due to shadowing and multipath phenomena.

In this chapter, we consider an elevation angle of  $40^\circ$  and an urban environment type modeled according to the Loo distribution parameters, the Markov matrix, and the probability vector (see Table 5.1).

The RTD to be considered for the signal to travel from the TN-NTN terminal to the NTN-gNB and back (or vice versa) is typically equal to 270.73 ms [2] for regenerative payload-based satellite.

Our reference TN-NTN system is designed to support the 5G NR technology with multiple scalable OFDM numerologies ( $\mu = 0$  to 4), each featured by a different SCS ( $SCS = 15kHz$  to  $240kHz$ ) according to the following equation [3]:

$$SCS = 15kHz \times 2^\mu, \quad (5.1)$$

**Table 5.1.** Channel model specifications.

Distribution type	Loo		
Environment type	Urban		
Elevation angle	40°		
Propagation conditions	State 1: LoS		
	State 2: Moderate Shadowing		
	State 3: Deep Shadowing		
$\mathbf{w}$	State 1	State 2	State 3
	0.4	0.2667	0.3333
$\mathbf{P}$	0.8628	0.0737	0.0635
	0.1247	0.8214	0.0539
	0.0648	0.0546	0.8806
$\alpha$ (dB)	-0.3	-8.0	-24.4
$\Psi$ (dB)	0.73	4.5	4.5
$MP$ (dB)	-15.9	-19.2	-19.0

where  $\mu$  is the numerology index. NR transmission supports the CP-OFDM in the downlink and both CP-OFDM and DFT-s-OFDM with cyclic prefix in the uplink. In the time domain, NR downlink and uplink transmissions are organized into frames and sub-frames. Each sub-frame lasts 1 ms and contains several slots depending on the considered numerology. Allocated resources are expressed in terms of RB, each consisting of 12 consecutive and equally spaced sub-carriers. In this work, we consider TN-NTN terminals interested in eMBB services and, hence, we select the numerology  $\mu = 0$  with  $SCS = 15kHz$ , suitable for eMBB applications requiring high data rates.

Let  $\mathcal{U}$  be the set of TN-NTN terminals that are requesting a given eMBB content. Let  $\mathcal{S}$  be the set of TN-NTN terminals served by the NTN-gNB and  $\mathcal{T}$  be the set of TN-NTN terminals served by the gNBs. All the interested TN-NTN terminals shall be served, hence:

$$|\mathcal{U}| = |\mathcal{S}| + |\mathcal{T}|. \quad (5.2)$$

We denote by  $\mathcal{R}$  the set of available RBs that shall not exceed the sum of the RBs assigned to the NTN-gNB (i.e.,  $|\mathcal{R}_S|$ ) plus the RBs allocated to the gNB (i.e.,  $|\mathcal{R}_T|$ ):

$$|\mathcal{R}| \leq |\mathcal{R}_S| + |\mathcal{R}_T|. \quad (5.3)$$

The objective of the proposed RRM scheme is to increase the ADR of the TN-NTN system while meeting the constraints on the TN-NTN terminals to be served and the number of RBs to be allocated. By referring to the TN-NTN system, the ADR is given by:

$$ADR = ADR_S + ADR_T, \quad (5.4)$$

where  $ADR_S$  is the sum of data rates of the TN-NTN terminals served by the NTN-gNB and  $ADR_T$  is the sum of data rates of the TN-NTN terminals served by the gNB.

The ADR of the Terrestrial Radio Access Network (T-RAN) is computed as:

$$ADR_T = \sum_{g \in \mathcal{G}} ADR_g, \quad (5.5)$$

when denoting  $\mathcal{G}$  as the set of gNBs.

The ADR of the TN-NTN system is precisely represented by the following formula:

$$ADR = \sum_{s \in \mathcal{S}} (D_S(s) \times |\mathcal{R}_S|) + \sum_{g \in \mathcal{G}} \sum_{t \in \mathcal{T}} (D_T(t, g) \times |\mathcal{R}_T(g)|), \quad (5.6)$$

where  $D_S(s)$  is the minimum data rate per RB related to the  $s$ -th TN-NTN terminal with the lowest MCS served by the NTN-gNB and  $D_T(t)$  is the minimum data rate per RB related to the  $t$ -th TN-NTN terminal with the lowest MCS served by the gNB.

The proposed RRM scheme exploits a heuristic approach to solve the following problem:

$$\begin{aligned} & \arg \max_{\mathcal{R}} ADR, & (5.7) \\ & \text{subject to (5.2) – (5.6).} \end{aligned}$$

## 5.4 The Proposed Cooperative TN-NTN Approach

The proposed cooperative TN-NTN scheme aims to efficiently allocate the radio resources between NTN-gNB and gNBs that share the same radio spectrum for delivering the requested eMBB service to all the interested TN-NTN terminals. The main objective is to provide an ADR in the integrated TN-NTN system that is higher than the one achievable in a terrestrial or in an NTN stand-alone system. To achieve this goal, our cooperative TN-NTN algorithm exploits the concept of multicast subgrouping by grouping all the target TN-NTN terminals in two subgroups,  $\mathcal{S}$  and  $\mathcal{T}$ , served by the NTN-gNB and the gNBs, respectively. The transmission parameters are set according to the lowest MCS (i.e., the most robust modulation) required by all the TN-NTN terminals to decode the required eMBB content.

The idea of the proposed scheme stems from the observation that, in terrestrial networks, the difference of the signal strength perceived by the UE in cell-edge and by the UE in cell-centers can be meaningful. On the contrary, such an effect is not pronounced that much in non-terrestrial systems. Hence, since TN-NTN terminals may perceive a higher NTN CSI than the terrestrial CSI, we propose that TN-NTN

terminals experiencing a better terrestrial channel than the non-terrestrial channel receive the eMBB content from the serving gNB; otherwise, they receive the eMBB content from the NTN-gNB. Furthermore, the proposed cooperative TN-NTN scheme: (i) selects a threshold CSI to increase the ADR of the integrated TN-NTN system, (ii) fairly allocates radio resources to both NTN-gNB and gNBs to provide a similar mean throughput to the TN-NTN terminals independently of the serving cell, (iii) while meeting the constraint to serve all the interested TN-NTN terminals.

The pseudo-code reported in Algorithm 2 describes the working logic of our cooperative TN-NTN approach.

---

**Algorithm 2** Cooperative TN-NTN approach
 

---

```

1: Input:  $\mathcal{U}, \mathcal{R}$ 
2:  $\mathcal{S} = \emptyset;$ 
3:  $\mathcal{T} = \emptyset;$ 
4:  $\mathcal{R}_S = \emptyset;$ 
5:  $\mathcal{R}_T = \emptyset;$ 
6:  $ADR = 0;$ 
7:  $\mathcal{C}_S = \text{CollectNonTerrestrialCSI}(U);$   $\triangleright$  set of CSI for NTN-gNB
8:  $\mathcal{C}_T = \text{CollectTerrestrialCSI}(U);$   $\triangleright$  set of CSI for gNBs
9:  $\mathcal{C} = \text{AscendingOrder}(\mathcal{C}_S \cup \mathcal{C}_T);$   $\triangleright$  set of CSI in ascending order
10: for  $c \in \mathcal{C}$  do
11:   for  $u \in \mathcal{U}$  do
12:     if  $(\mathcal{C}_T(c, u) > c)$  then
13:       add  $u$  in  $\mathcal{T}(c);$ 
14:     else if  $(\mathcal{C}_T(u) \leq c)$  then
15:       add  $u$  in  $\mathcal{S}(c);$ 
16:     end if
17:   end for
18:   if  $\text{IsEmpty}(\mathcal{S}(c)) == \text{TRUE} \ \& \ \text{IsEmpty}(\mathcal{T}(c)) == \text{FALSE}$  then
19:      $\mathcal{R}_S(c) = \emptyset;$ 
20:      $\mathcal{R}_T(c) = \text{AllocateAllRB}(\mathcal{R});$ 
21:      $ADR_T(c) = \text{ComputeADR}(\mathcal{T}(c), \mathcal{R}_T(c));$ 
22:      $ADR(c) = ADR_T(c);$ 
23:   else if  $\text{IsEmpty}(\mathcal{S}(c)) == \text{FALSE} \ \& \ \text{IsEmpty}(\mathcal{T}(c)) == \text{TRUE}$  then
24:      $\mathcal{R}_T(c) = \emptyset;$ 
25:      $\mathcal{R}_S(c) = \text{AllocateAllRB}(\mathcal{R});$ 
26:      $ADR_S(c) = \text{ComputeADR}(\mathcal{S}(c), \mathcal{R}_S(c));$ 
27:      $ADR(c) = ADR_S(c);$ 

```

---

---

```

28:  else if IsEmpty( $\mathcal{S}(c)$ )==FALSE & IsEmpty( $\mathcal{T}(c)$ )==FALSE then
29:      ( $\mathcal{R}_S(c), \mathcal{R}_T(c)$ ) = SplitRB( $\mathcal{R}$ );
30:       $ADR_S(c)$  = ComputeADR( $\mathcal{S}(c), \mathcal{R}_S(c)$ );
31:       $ADR_T(c)$  = ComputeADR( $\mathcal{T}(c), \mathcal{R}_T(c)$ );
32:       $ADR(c)$  =  $ADR_S$  +  $ADR_T$ ;
33:  end if
34:  if  $ADR(c) \geq ADR$  then
35:       $ADR$  =  $ADR(c)$ ;
36:       $\mathcal{R}_S$  =  $\mathcal{R}_S(c)$ ;
37:       $\mathcal{R}_T$  =  $\mathcal{R}_T(c)$ ;
38:       $\mathcal{S}$  =  $\mathcal{S}(c)$ ;
39:       $\mathcal{T}$  =  $\mathcal{T}(c)$ ;
40:  else
41:      break;
42:  end if
43: end for
44: Output:  $\mathcal{S}, \mathcal{T}, \mathcal{R}_S, \mathcal{R}_T, ADR$ 

```

---

The algorithm begins by receiving as input the sets of TN-NTN terminals and radio resources, i.e.,  $\mathcal{U}$  and  $\mathcal{R}$ , respectively (line 1). The first step is to organize all TN-NTN terminal channel feedbacks received from both gNBs (line 7) and NTN-gNB (line 8) in ascending order (line 9). Then, the algorithm proceeds to split TN-NTN terminals by choosing the threshold CSI above which TN-NTN terminals are served by gNBs and below which TN-NTN terminals are served by the NTN-gNB (lines 12-17). The selected threshold CSI is the one that provides the highest system ADR (lines 34-42). During the iterations on the CSI, three possible scenarios may occur:

1. All the TN-NTN terminals are served by gNBs (lines 18-22): all the available RBs are allocated to gNBs and the system ADR is given by the contribution of the terrestrial ADR only.
2. All the TN-NTN terminals are served by the NTN-gNB (lines 23-27): all the available RBs are allocated to the NTN-gNB and the system ADR is given by the contribution of the NTN ADR only.
3. The TN-NTN terminals are served by either NTN-gNB or gNBs (lines 28-33): the set of available RBs is split between the NTN-gNB and gNBs to ensure fairness in terms of transmission data rate. Hence, the system ADR is given by the contributions of terrestrial and NTN ADR.

The implementation of the proposed algorithm benefits from a linear computational complexity that is  $O(|\mathcal{C}| \cdot |\mathcal{I}|)$ .

## 5.5 Performance Evaluation

### 5.5.1 Simulation Model

Simulative campaigns have been carried out by using a dedicated simulator implemented in MATLAB and specifically designed for a cooperative TN-NTN system. The large scale calibration follows 3GPP guidelines [2]. Each simulation has been run multiple times to attain 95% confidence intervals.

We assume that each TN-NTN terminal CSI varies every TTI and both NTN-gNB and gNB schedule the TN-NTN terminals every subframe of 1 ms. We consider one NTN-gNB and, for simplicity, only one gNB. More information about the major modeling parameters is available in Table 5.2.

We assess an urban environment and model the following:

- **Case A**, where the channel bandwidth varies from 5 to 50 MHz (corresponding to 25, 52, 79, 106, 133, 160, 216, and 270 available RBs [20]), and the number of TN-NTN terminals is set to 1000.
- **Case B**, where the channel bandwidth is fixed to 20 MHz (i.e., 106 RBs), and the number of TN-NTN terminals varies from 300 to 900.
- **Case C**, where the channel bandwidth is fixed to 50 MHz (i.e., 270 RBs), the number of TN-NTN terminals is set to 1000, and different distributions of the TN-NTN terminals are considered (i.e., uniform, cell-center, and cell-edge).

The performance of our cooperative integrated TN-NTN system has been compared against that related to only terrestrial and only NTN systems. We evaluate the following metrics:

- **Mean Throughput** is the average data rate experienced by the TN-NTN terminals.
- **ADR** is the sum of all the data rates experienced by the TN-NTN terminals.
- **Spectral Efficiency** quantifies how much the radio spectrum is efficiently exploited and computed as the ratio between the number of bits delivered to the TN-NTN terminals and the reference channel bandwidth.
- **Resource Blocks** represent the percentage of RBs allocated to the NTN-RAN and the T-RAN when applying the proposed cooperative TN-NTN approach.

**Table 5.2.** Main Modeling Parameters [3], [2].

PARAMETER	VALUE
NTN-gNB	Regenerative payload-based GEO satellite
NTN-gNB altitude	35786 km
NTN-gNB EIRP density	53.5 dBW/MHz
NTN-gNB Tx max gain	45.5 dBi
NTN beam diameter	450 km
gNB Tx max gain	15 dBi
gNB Tx power	46 dBm
gNB cell diameter	500 m
TN-NTN terminal type	Handheld
TN-NTN terminal distribution	100% outdoor
TN-NTN terminal speed	3 kmph
TN-NTN terminal antenna type	Omnidirectional with linear polarization
TN-NTN terminal antenna gain	0 dBi
TN-NTN terminal noise figure	9 dB
TN-NTN terminal Tx power	23 dBm
Carrier frequency	S-band (i.e., 2 GHz)
Numerology	0
Sub-carrier spacing	15 kHz
Transmission time interval	1 ms

### 5.5.2 Analysis of Results

The selected results illustrate the performance of the proposed cooperative TN-NTN approach, the terrestrial CMS, and the NTN CMS. Specifically for the latter, we evaluate two cases labeled *upper bound* (i.e., all the available RBs are allocated for the transmission from the NTN-gNB) and *lower bound* (i.e., only one RB is allocated for the transmission from the NTN-gNB). The choice to consider the two limit conditions is to provide a complete view of the whole range of achievable results. Actually, exploiting the NTN resources represents a valuable solution to offer global connectivity owing to the wide coverage it provides. By virtue of the above, in the upper bound case, we considered the unlikely situation in which the NTN system assigns all available RBs to serve TN-NTN terminals distributed in an infinitesimal area (i.e., the coverage area of the terrestrial gNB) with respect to the wide NTN coverage area. Hence, we consider the lower bound case as a more realistic scenario to be compared with our proposal.

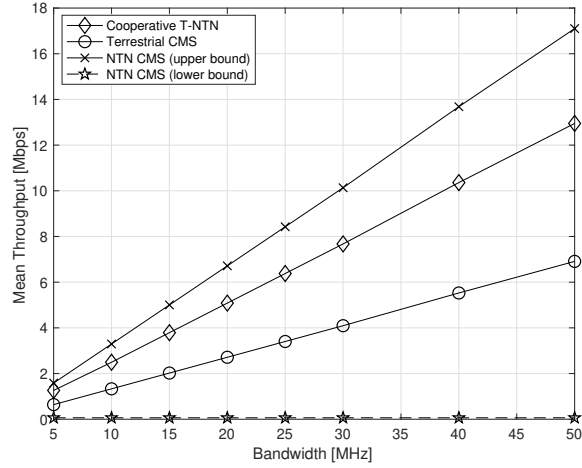

(a) Mean Throughput

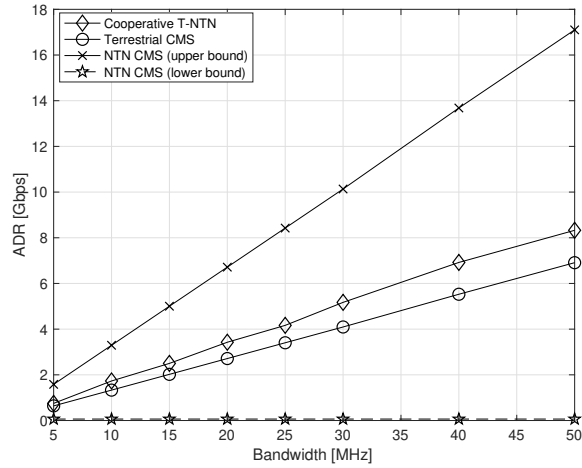

(b) ADR

**Fig. 5.2.** Case A: Performance results under a varying channel bandwidth.

### Performance Results in Case A

Fig. 5.2 shows the mean throughput and the ADR for cooperative TN-NTN, terrestrial CMS, and NTN CMS (both upper and lower bound) under a varying NR channel bandwidth. It can be noted that our proposed cooperative solution provides the best system-level results in comparison to both terrestrial CMS and NTN CMS (lower bound) schemes. As depicted in Fig. 5.2 (a), the mean throughput increases with the widening of the channel bandwidth and, for the proposed cooperative TN-NTN approach, ranges from 1.26 Mbps to 12.95 Mbps. Also, the ADR (Fig. 5.2 (b)) follows the same trend as the mean throughput and grows from 0.75 Gbps to 8.32 Gbps.

### Performance Results in Case B

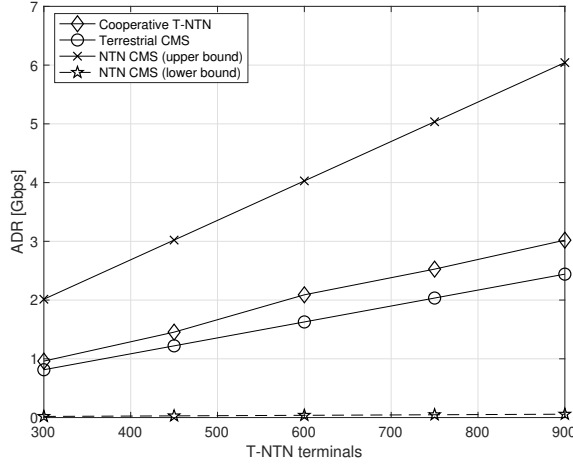
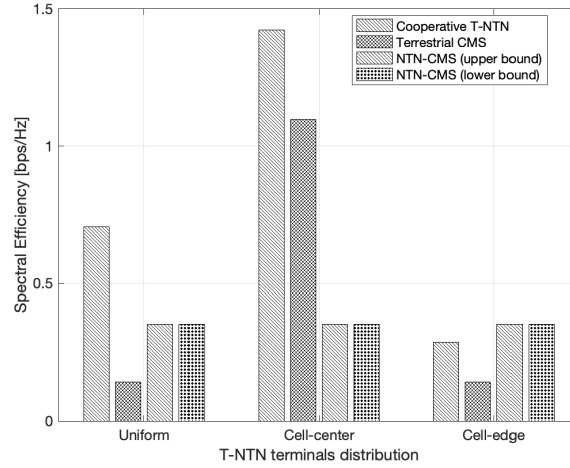

**Fig. 5.3.** Case B: ADR under a varying number of TN-NTN terminals.

Fig. 5.3 illustrates the ADR for cooperative TN-NTN, terrestrial CMS, and NTN CMS (both upper and lower bound) under a varying number of TN-NTN terminals. We can notice that our proposed cooperative solution achieves the highest ADR values than both terrestrial CMS and NTN CMS (lower bound) schemes. Furthermore, the ADR follows a growing trend when increasing the number of TN-NTN terminals in the system since the ADR is given by the contributions in data rates of all TN-NTN terminals. In particular, the ADR ranges from 0.96 Gbps to 3 Gbps for our proposed approach.

### Performance Results in Case C

Figs. 5.4 and 5.5 plot, respectively, the spectral efficiency and resource blocks when considering three different TN-NTN terminals distributions: uniform, cell-center, and cell-edge. Specifically, the spectral efficiency (Fig. 5.4) is compared among cooperative TN-NTN, terrestrial CMS, and NTN CMS (both upper and lower bound). It is worth noting that our proposal reaches the highest values of the spectral efficiency in both uniform and cell-center distributions. Differently, the spectral efficiency is lower when distributing the TN-NTN terminals at the cell edges. The reason is that a more robust modulation is needed to decode data at the cell edges. Hence, the channel bandwidth is exploited to deliver useful bits and also to transmit a larger amount of redundancy bits than when adopting a less robust modulation (i.e., cell-center distribution).



**Fig. 5.4.** Case C: Spectral efficiency under varying TN-NTN terminals distribution.

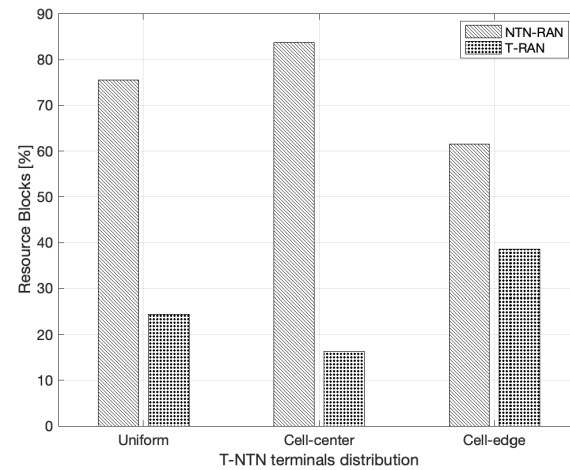

**Fig. 5.5.** Case C: Percentage of allocated RBs under varying TN-NTN terminals distribution.

Fig. 5.5 shows the percentage of radio resources allocated to both NTN-RAN and T-RAN when applying our proposed cooperative TN-NTN approach, which follows a fair policy in the resource allocation. Indeed, the percentage of RBs allocated to the two RANs is computed to provide the same data rates to TN-NTN terminals served by the gNB as to those TN-NTN terminals served by the NTN-gNB. Finally, it can be noted that as the distribution of the TN-NTN terminals moves from the cell-center to the cell-edge, the percentage of RBs assigned to the NTN-gNB tends to that allocated to the gNB.

## 5.6 Conclusions

In this chapter, we focused on an integrated TN-NTN system, which is based on the emerging 5G NR technology and exploited to deliver multicast services. A cooperative RRM scheme, which leverages the principles of multicast subgrouping technique, has been proposed for scenarios wherein TN-NTN terminals are under both terrestrial and NTN coverage. TN-NTN terminals are grouped in two disjoint sets served by the gNB and the NTN-gNB, respectively, in such a way to improve the overall network throughput with respect to the case of terrestrial or NTN stand-alone systems. Network resources are fairly allocated to offer a similar mean throughput to TN-NTN terminals independently of the serving base station. Achieved simulation results show that the proposed cooperative TN-NTN approach significantly enhances the system performance of the integrated TN-NTN network. Future works will focus on applying the designed cooperative policy to both partially overlapped GEO satellites and lower orbit satellites (i.e., LEO). The former case will also investigate the impact of beam radius on the performance of cooperative resource allocation in multi-beam NTN systems. In the latter case, LEO mobility will be an important aspect to consider in the defined approach.

## Conclusions

The rapid proliferation of smart devices, technological advancements, and the exponential growth of demand for new services have characterized the last decade of telecommunications progress up to the current 5G NR technology. These developments fueled the interest of both Information and Communications Technology (ICT) operators and researchers in the Non-Terrestrial Network (NTN) systems as a means to provide ubiquitous services by achieving global network coverage. The relevance of NTN across two design options (i.e., standalone satellite vs. integrated Terrestrial/Non-Terrestrial Network (TN-NTN) architecture) will rise further in beyond-5G ecosystem.

This Ph.D. thesis provides the recent progress in the standardization and development of NR technology and NTN in 5G and beyond, reviews the importance of NTN in wireless systems, investigates new challenges and open issues, and proposes novel approaches to provide valid research contributions and innovation to the state-of-art. This Ph.D. thesis achieves the results below.

- The main design features of the 5G NR system are outlined by covering topics of the key innovative aspects introduced in the system architecture and protocol stack (i.e., PHY layer, user-/control-plane protocols). This information is representative of the latest Releases 16 of the 38th series of 3GPP specifications. Furthermore, the results of system-level simulations are analyzed to assess the overall system performance, and useful considerations are drawn on the impact of scalable numerology on the 5G NR performance. Specifically, we establish that: *(i)* lower numerologies are better suited for eMBB services with their higher volumes of data and without the stringent requirements in terms of latency; *(ii)* higher numerologies satisfy the requirement of (ultra-)low latency, which is essential for URLLC, at the expense of some reduction in the peak data rate; *(iii)* higher numerologies can also be exploited at higher frequencies while lower numerologies suit lower frequencies

since the number of useful bits per RB delivered in a TTI decreases under higher numerologies. Furthermore, future research directions are briefly outlined.

- An overview of the NTN evolution is provided in connection to cellular communications from 1G to 4G by investigating the core research topics, such as the integration of non-terrestrial and terrestrial networks, the radio resource allocation, and the mobility. This study also highlights the importance of NTN in 5G technology by further focusing on its role toward 6G and contributes a summary of the current 3GPP research activities in supporting the NTN as part of the 5G NR technology. The NTN demonstrates many effects due to its characteristics, i.e., long propagation delay, the motion of NGSO satellites, and many others. Hence, main open issues (mobility, propagation delay, and radio resource allocation) are investigated to understand future attractive research directions.
- The Single-Frequency Multi-Beam Transmission (SF-MBT) scheme is proposed for broadcasting eMBB services through synchronous beam transmissions in 5G NR multi-beam NTN systems. Our SF-MBT approach foresees that the beams belonging to the same satellite are grouped into different MBSFN Beam Area (MBA), wherein all the beams are synchronized in time to perform a simultaneous transmission of a certain service over the same radio resources. The MBAs may be *independent* or *overlapping*. In particular, an independent MBA comprises of beams wherein only one content item is delivered, whereas overlapping MBAs include at least one beam belonging to more MBAs, each delivering different content items. Furthermore, our SF-MBT scheme splits the radio resources among the overlapping MBAs to avoid interference during data delivery, whereas all radio resources are allocated to independent MBAs. The proposed solution aims to overcome the limitations of the currently implemented policies, where frequencies are re-used across the beams of the same satellite to avoid inter-beam interference. Moreover, extensive simulations confirm the effectiveness of the developed scheme. Indeed, the SF-MBT scheme achieves more performing system-wide results in terms of ADR, mean throughput, and system spectral efficiency than four- and three-color frequency re-use approaches. Future work needs to address new radio resource management strategies for handling varying traffic demands characterized by different quality requirements.
- An integrated TN-NTN system, based on the emerging 5G NR technology and exploited to deliver multicast services, is investigated. A cooperative RRM scheme, which leverages the principles of multicast subgrouping technique, has been proposed for scenarios wherein TN-NTN terminals are under both terrestrial and

NTN coverage. TN-NTN terminals are grouped in two disjoint sets served by the gNB and the NTN-gNB, respectively, in such a way to improve the overall network throughput with respect to the case of terrestrial or NTN stand-alone systems. Network resources are fairly allocated to offer a similar mean throughput to TN-NTN terminals independently of the serving base station. Achieved simulation results show that the proposed cooperative TN-NTN approach significantly enhances the system performance of the integrated TN-NTN network. In detail, the mean throughput increases with the widening of the channel bandwidth and ranges from 1.26 Mbps to 12.95 Mbps. The ADR follows the same trend as the mean throughput and grows from 0.75 Gbps to 8.32 Gbps. The ADR shows a growing trend when increasing the number of TN-NTN terminals in the system since the ADR is given by the contributions of data rates of all TN-NTN terminals. Furthermore, our proposal better exploits the radio spectrum in both uniform and cell-center distributions, and the percentage of RBs assigned to the NTN-gNB tends to that allocated to the gNB when the distribution of the TN-NTN terminals moves from the cell-center to the cell-edge. Future works will focus on applying the designed cooperative policy to both partially overlapped GEO satellites and lower orbit satellites (i.e., LEO). The former case will also investigate the impact of beam radius on the performance of cooperative resource allocation in multi-beam NTN systems. In the latter case, LEO mobility will be an important aspect to consider in the defined approach.

This Ph.D. thesis comes out from a background on multicast/broadcast transmissions in 5G terrestrial and satellite networks proven by scientific publications in international journals and conferences shown in the List of Publications. However, the chapters of this Ph.D. thesis do not include all publications.

Instead, the training period in Finland at Ericsson premises, where I conducted research activities on Non-Terrestrial Network in 5G, inspired and convinced me to focus this Ph.D. thesis on space communications and their rising importance in 5G and beyond systems.



---

## References

- [1] A. Zaidi, R. Baldemair, S. Faxér, V. Molés-Case, and Z. Wang. Designing for the Future: the 5G NR Physical Layer. *Ericsson Technology Review*, 2017.
- [2] 3GPP. TR 38.821; Solutions for NR to support Non-Terrestrial Networks (NTN); Rel.16. Technical report, 3GPP, 2020.
- [3] 3GPP. TR 38.811; Study on New Radio (NR) to support Non-Terrestrial Networks; Rel.15. Technical report, 3GPP, 2019.
- [4] N. Bhushan, T. Ji, O. Koymen, J. Smee, J. Soriaga, S. Subramanian, and Y. Wei. Industry Perspective: 5G Air Interface System Design Principles. *IEEE Wireless Communications*, 24(5):6–8, 2017.
- [5] ITU-R. Minimum Requirements Related to Technical Performance for IMT-2020 Radio Interface(s). Report ITU-R M.2410-0, 2017.
- [6] Ericsson. Streaming video – from megabits to gigabytes. Ericsson Mobility Report, 2018.
- [7] T. Barnett, S. Jain, U. Andra, and T. Khurana. Cisco Visual Networking Index (VNI) Complete Forecast Update, 2017–2022. CISCO VNI, 2018.
- [8] V. Jorroughi, M. À. Vázquez, A. I. Pérez-Neira, and B. Devillers. Onboard Beam Generation for Multibeam Satellite Systems. *IEEE Transactions on Wireless Communications*, 16(6):3714–3726, 2017. doi: 10.1109/TWC.2017.2687924.
- [9] J. Liu, Y. Shi, Z. M. Fadlullah, and N. Kato. Space-Air-Ground Integrated Network: A Survey. *IEEE Communications Surveys & Tutorials*, 20(4):2714–2741, 2018. doi: 10.1109/COMST.2018.2841996.
- [10] S. Parkvall, E. Dahlman, A. Furuskar, and M. Frenne. NR: The New 5G Radio Access Technology. *IEEE Communications Standards Magazine*, 1(4):24–30, 2017.
- [11] A. Zaidi, R. Baldemair, H. Tullberg, H. BJORKEGREN, L. Sundstrom, J. Medbo, C. Kilinc, and I. Da Silva. Waveform and Numerology to Support 5G Services and Requirements. *IEEE Communications Magazine*, 54(11):90–98, 2016.
- [12] J. Liu, K. Au, A. Maaref, J. Luo, H. Baligh, H. Tong, A. Chassaigne, and J. Lorca. Initial Access, Mobility, and User-Centric Multi-Beam Operation in 5G New Radio. *IEEE Communications Magazine*, 56(3):35–41, 2018.

- [13] X. Lin, J. Li, R. Baldemair, J. T. Cheng, S. Parkvall, D. C. Larsson, H. Koorapaty, M. Frenne, S. Falahati, A. Grovlen, and K. Werner. 5G New Radio: Unveiling the Essentials of the Next Generation Wireless Access Technology. *IEEE Communications Standards Magazine*, 3(3):30–37, 2019.
- [14] M. Fuentes, J. L. Carcel, C. Dietrich, L. Yu, E. Garro, V. Pauli, F. I. Lazarakis, O. Grøndalen, Ö. Bulakci, J. Yu, W. Mohr, and D. Gómez-Barquero. 5G New Radio Evaluation Against IMT-2020 Key Performance Indicators. *IEEE Access*, 8:110880–110896, 2020. doi: 10.1109/ACCESS.2020.3001641.
- [15] 3GPP. TS 38.300; NR; NR and NG-RAN Overall Description, Stage 2; Rel. 16. Technical Specification, 3GPP, 2020.
- [16] 3GPP. TS 38.401; NG-RAN; Architecture description; Rel.16. Technical Specification, 3GPP, 2020.
- [17] 3GPP. TS 37.340; Evolved Universal Terrestrial Radio Access (E-UTRA) and NR; Multi-connectivity; Stage 2; Rel. 16. Technical Specification, 3GPP, 2020.
- [18] 3GPP. TS 23.501; System Architecture for the 5G System; Rel. 16. Technical Specification, 3GPP, 2020.
- [19] 3GPP. TR 36.842; Study on Small Cell enhancements for E-UTRA and E-UTRAN; Higher layer aspects; Rel.12. Technical report, 3GPP, 2014.
- [20] 3GPP. TS 38.104; NR; Base Station (BS) radio transmission and reception; Rel. 16. Technical Specification, 3GPP, 2020.
- [21] 3GPP. TS 38.214; NR; Physical layer procedures for data; Rel. 16. Technical Specification, 3GPP, 2020.
- [22] 3GPP. TS 38.211; NR; Physical channels and modulation; Rel. 16. Technical Specification, 3GPP, 2020.
- [23] 3GPP. TS 38.213; NR; Physical layer procedures for control; Rel.16. Technical Specification, 3GPP, 2020.
- [24] 3GPP. TR 38.804; Study on New Radio Access Technology; Radio Interface Protocol Aspects; Rel.14. Technical report, 3GPP, 2014.
- [25] P. K. Chowdhury, M. Atiquzzaman, and W. Ivancic. Handover Schemes in Satellite Networks: State-of-the-Art and Future Research Directions. *IEEE Communications Surveys & Tutorials*, 8(4):2–14, 2006. doi: 10.1109/COMST.2006.283818.
- [26] P. Chini, G. Giambene, and S. Kota. A Survey on Mobile Satellite Systems. *International Journal of Satellite Communications and Networking*, 28(1):29–57, 2010. doi: 10.1002/sat.941.
- [27] P. Arapoglou, K. Liolis, M. Bertinelli, A. Panagopoulos, P. Cottis, and R. De Gaudenzi. MIMO over Satellite: A Review. *IEEE Communications Surveys & Tutorials*, 13(1):27–51, 2011. doi: 10.1109/SURV.2011.033110.00072.
- [28] M. De Sanctis, E. Cianca, G. Araniti, I. Bisio, and R. Prasad. Satellite Communications Supporting Internet of Remote Things. *IEEE Internet of Things Journal*, 3(1):113–123, 2016. doi: 10.1109/JIOT.2015.2487046.

- [29] R. Radhakrishnan, W. W. Edmonson, F. Afghah, R. M. Rodriguez-Osorio, F. Pinto, and S. C. Burleigh. Survey of Inter-Satellite Communication for Small Satellite Systems: Physical Layer to Network Layer View. *IEEE Communications Surveys & Tutorials*, 18(4):2442–2473, 2016. doi: 10.1109/COMST.2016.2564990.
- [30] C. Niephaus, M. Kretschmer, and G. Ghinea. QoS Provisioning in Converged Satellite and Terrestrial Networks: A Survey of the State-of-the-Art. *IEEE Communications Surveys & Tutorials*, 18(4):2415–2441, 2016. doi: 10.1109/COMST.2016.2561078.
- [31] H. Kaushal and G. Kaddoum. Optical Communication in Space: Challenges and Mitigation Techniques. *IEEE Communications Surveys & Tutorials*, 19(1):57–96, 2017. doi: 10.1109/COMST.2016.2603518.
- [32] S. C. Burleigh, T. De Cola, S. Morosi, S. Jayousi, E. Cianca, and C. Fuchs. From Connectivity to Advanced Internet Services: A Comprehensive Review of Small Satellites Communications and Networks. *Wireless Communications and Mobile Computing*, 2019. doi: <https://doi.org/10.1155/2019/6243505>.
- [33] B. Li, Z. Fei, C. Zhou, and Y. Zhang. Physical-Layer Security in Space Information Networks: A Survey. *IEEE Internet of Things Journal*, 7(1):33–52, 2020. doi: 10.1109/JIOT.2019.2943900.
- [34] 3GPP. TR 22.822; Study on using Satellite Access in 5G; Rel.16. Technical report, 3GPP, 2018.
- [35] Network Innovations. Communicate. Anywhere. <http://www.networkinv.com/solutions/maritime-satellite-communications/>.
- [36] 3GPP. TS 22.119; Maritime Communication Services over 3GPP; Rel. 16. Technical Specification, 3GPP, 2019.
- [37] 3GPP. TS 38.401; NG-RAN; Architecture Description; Rel. 15. Technical Specification, 3GPP, 2019.
- [38] 3GPP. TR 38.874; NR, Study on Integrated Access and Backhaul; Rel.16. Technical report, 3GPP, 2018.
- [39] B. Evans, M. Werner, E. Lutz, M. Bousquet, G. E. Corazza, G. Maral, and R. Rumeau. Integration of Satellite and Terrestrial Systems in Future Multimedia Communications. *IEEE Wireless Communications*, 12(5):72–80, 2005. doi: 10.1109/MWC.2005.1522108.
- [40] F. Ananasso and F. D. Priscoli. Issues on the Evolution Towards Satellite Personal Communication Networks. In *Proceedings of GLOBECOM '95*, volume 1, pages 541–545 vol.1, 1995. doi: 10.1109/GLOCOM.1995.501985.
- [41] 3GPP. TS 23.002; Technical Specification Group Services and System Aspects, Network Architecture. Technical Specification, 3GPP, 1999.
- [42] 3GPP. TS 25.401; Technical Specification Group Radio Access Network, UTRAN overall description; Rel.4. Technical Specification, 3GPP, 2001.
- [43] 3GPP. TS 23.246; Technical Specification Group Services and System Aspects; Multimedia Broadcast/Multicast Service (MBMS), Architecture and functional description; Rel.6. Technical Specification, 3GPP, 2007.

- [44] ITU. Deployment of IMT-2000 Systems, 2003. URL [https://www.itu.int/dms\\_pub/itu-r/opb/hdb/R-HDB-60-2003-PDF-E.pdf](https://www.itu.int/dms_pub/itu-r/opb/hdb/R-HDB-60-2003-PDF-E.pdf).
- [45] A. Gunttsch, M. Ibnkahla, G. Losquadro, M. Mazzella, D. Roviras, and A. Timm. EU's R&D Activities on Third Generation Mobile Satellite Systems (S-UMTS). *IEEE Communications Magazine*, 36(2):104–110, 1998. doi: 10.1109/35.648775.
- [46] L. Fan, R. E. Sheriff, and J. G. Gardiner. Satellite-UMTS Service Provision using IP-based Technology. In *VTC2000-Spring. 2000 IEEE 51st Vehicular Technology Conference Proceedings (Cat. No.00CH37026)*, volume 3, pages 1970–1974 vol.3, 2000. doi: 10.1109/VETECS.2000.851616.
- [47] J. J. Garrahan, P. A. Russo, K. Kitami, and R. Kung. Intelligent Network Overview. *IEEE Communications Magazine*, 31(3):30–36, 1993. doi: 10.1109/35.199607.
- [48] C. E. Perkins. Mobile IP. *IEEE Communications Magazine*, 35(5):84–99, 1997. doi: 10.1109/35.592101.
- [49] K. Narenthiran, M. Karaliopoulos, B. G. Evans, W. De-Win, M. Dieudonne, P. Henrio, M. Mazzella, E. Angelou, I. Andrikopoulos, P. I. Philippopoulos, D. Axiotis, N. Dimitriou, A. Polydoros, G. E. Corazza, and A. Vanelli-Coralli. S-UMTS Access Network for Broadcast and Multicast Service Delivery: the SATIN Approach. *International Journal of Satellite Communications and Networking*, 22(1):87–111, 2004. doi: 10.1002/sat.776.
- [50] M. Karaliopoulos, K. Narenthiran, B. Evans, P. Henrio, M. Mazzella, W. de Win, M. Dieudonne, P. Philippopoulos, D. I. Axiotis, I. Andrikopoulos, I. Mertzanis, G. E. Corazza, A. Vanelli-Coralli, N. Dimitriou, and A. Polydoros. Satellite Radio Interface and Radio Resource Management Strategy for the Delivery of Multicast/Broadcast Services via an Integrated Satellite-Terrestrial System. *IEEE Communications Magazine*, 42(9):108–117, 2004. doi: 10.1109/MCOM.2004.1355878.
- [51] Y. F. Hu, R. E. Sheriff, E. Del Re, R. Fantacci, and G. Giambene. Satellite-UMTS Traffic Dimensioning and Resource Management Technique Analysis. *IEEE Transactions on Vehicular Technology*, 47(4):1329–1341, 1998. doi: 10.1109/25.728523.
- [52] N. Efthymiou, Y. F. Hu, R. E. Sheriff, and A. Properzi. Inter-Segment Handover Algorithm for an Integrated Terrestrial/Satellite-UMTS Environment. In *Ninth IEEE International Symposium on Personal, Indoor and Mobile Radio Communications (Cat. No.98TH8361)*, volume 2, pages 993–998 vol.2, 1998. doi: 10.1109/PIMRC.1998.734709.
- [53] P. Nay and C. Zhou. Vertical Handoff Decision Algorithm for Integrated UMTS and LEO Satellite Networks. In *2009 WRI International Conference on Communications and Mobile Computing*, volume 2, pages 180–184, 2009. doi: 10.1109/CMC.2009.135.
- [54] D. Boudreau, G. Caire, G. E. Corazza, R. De Gaudenzi, G. Gallinaro, M. Luglio, R. Lyons, J. Romero-Garcia, A. Vernucci, and H. Widmer. Wide-band CDMA for the UMTS/IMT-2000 satellite component. *IEEE Transactions on Vehicular Technology*, 51(2):306–331, 2002. doi: 10.1109/25.994808.

- [55] P. Taaghoul, B. G. Evans, E. Buracchini, G. De Gaudinaro, J. H. Lee, and C. G. Kang. Satellite UMTS/IMT-2000 W-CDMA Air Interfaces. *IEEE Communications Magazine*, 37(9):116–126, 1999. doi: 10.1109/35.790970.
- [56] M. A. K. Sumanasena and B. G. Evans. Adaptive Modulation and Coding for Satellite-UMTS. In *IEEE 54th Vehicular Technology Conference. VTC Fall 2001. Proceedings (Cat. No. 01CH37211)*, volume 1, pages 116–120 vol.1, 2001. doi: 10.1109/VTC.2001.956567.
- [57] T. C. Tozer and D. Grace. Broadband Service Delivery from High Altitude Platforms. COMMUNICATE 2000, Sector: Next Generation Networks, 2000.
- [58] E. Falletti, M. Mondin, F. Dervis, and D. Grace. Integration of a HAPS within a Terrestrial UMTS Network: Interference Analysis and Cell Dimensioning. *Wireless Personal Communications*, 2003.
- [59] G. Araniti, A. Iera, and A. Molinaro. The Role of HAPS in Supporting Multimedia Broadcast and Multicast Services in Terrestrial-Satellite Integrated Systems. *Wireless Personal Communications*, 2005.
- [60] 3GPP. TS 36.401; Technical Specification Group Radio Access Network; Evolved Universal Terrestrial Radio Access Network; Rel. 8. Technical Specification; 3GPP, 2007.
- [61] E. Cianca, M. De Sanctis, and M. Ruggieri. Convergence Towards 4G: A Novel View of Integration. *Wireless Personal Communications*, 2005.
- [62] B. Di, H. Zhang, L. Song, Y. Li, and G. Y. Li. Data Offloading in Ultra-Dense LEO-Based Integrated Terrestrial-Satellite Networks. In *2018 IEEE Global Communications Conference (GLOBECOM)*, pages 1–6, 2018. doi: 10.1109/GLOCOM.2018.8647954.
- [63] E. Corbel, I. Buret, J. D. Gayrard, G. E. Corazza, and A. Bolea-Alamanac. Hybrid Satellite Terrestrial Mobile Network for 4G: Candidate Architecture and Space Segment Dimensioning. In *2008 4th Advanced Satellite Mobile Systems*, pages 162–166, 2008. doi: 10.1109/ASMS.2008.35.
- [64] A. Vanelli-Coralli, G. E. Corazza, G. K. Karagiannidis, P. T. Mathiopoulos, D. S. Michalopoulos, C. Mosquera, S. Papaharalabos, and S. Scalise. Satellite Communications: Research Trends and Open Issues. In *2007 International Workshop on Satellite and Space Communications*, pages 71–75, 2007. doi: 10.1109/IWSSC.2007.4409393.
- [65] Y. Labrador, M. Karimi, D. Pan, and J. Miller. An Approach to Cooperative Satellite Communications in 4G Mobile Systems. *Journal of Communications*, 4(10), 2009.
- [66] G. Araniti, I. Bisio, M. De Sanctis, F. Rinaldi, and A. Sciarrone. Joint Coding and Multicast Subgrouping Over Satellite-eMBMS Networks. *IEEE Journal on Selected Areas in Communications*, 36(5):1004–1016, 2018. doi: 10.1109/JSAC.2018.2832818.
- [67] G. Araniti, M. Condoluci, and A. Petrolino. Efficient Resource Allocation for Multicast Transmissions in Satellite-LTE Networks. In *2013 IEEE Global Communications Conference (GLOBECOM)*, pages 3023–3028, 2013. doi: 10.1109/GLOCOM.2013.6831535.
- [68] I. Bisio, F. Lavagetto, G. Luzzati, and M. Marchese. Smartphones Apps Implementing a Heuristic Joint Coding for Video Transmissions over Mobile Networks. *Mobile Networks and Applications*, 19(4):552–562, 2014.

- [69] 3GPP. TS 36.440; General aspects and principles for interfaces supporting Multimedia Broadcast Multicast Service (MBMS) within E-UTRAN; Rel.14. Technical Specification; 3GPP, 2017.
- [70] U. Park, H. W. Kim, D. S. Oh, and B.-J. Ku. A Dynamic Bandwidth Allocation Scheme for a Multi-spot-beam Satellite System. *ETRI Journal*, 34(4), 2012.
- [71] U. Park, H. W. Kim, D. S. Oh, and B.-J. Ku. Interference-Limited Dynamic Resource Management for an Integrated Satellite/Terrestrial System. *ETRI Journal*, 36(4), 2014.
- [72] V. Joroughi. Advance Precoding Technique for Coordinated Multibeam Satellite Systems. In *American Institute of Aeronautics and Astronautics (AIAA) conference*, 2016. doi: 10.2514/6.2016-5730.
- [73] A. Guidotti, A. Vanelli-Coralli, G. Taricco, and G. Montorsi. User Clustering for Multicast Precoding in Multi-Beam Satellite Systems. *IEEE Transactions on Wireless Communications*, 2017. URL <https://arxiv.org/pdf/1706.09482.pdf>.
- [74] I. F. Akyildiz, J. Xie, and S. Mohanty. A Survey of Mobility Management in Next-Generation all-IP-based Wireless Systems. *IEEE Wireless Communications*, 11(4):16–28, 2004. doi: 10.1109/MWC.2004.1325888.
- [75] G. E. Corazza, M. Ruggieri, and F. Vatalaro F. Santucci. Handover Procedures in Integrated Satellite and Terrestrial Mobile Systems. In *Third International Mobile Satellite Conference*, 1993.
- [76] T. C. Hong, K. S. Kang, D.-S. Ahn, and H.-J. Lee. Adaptive Buffering Scheme for Streaming Service in Intersystem Handover between Terrestrial and Satellite Systems. In *2008 IEEE International Symposium on Consumer Electronics*, pages 1–4, 2008. doi: 10.1109/ISCE.2008.4559547.
- [77] X. Mohanty, J. Xie, and S. Mohanty. Performance Analysis of a Novel Architecture to Integrate Heterogeneous Wireless Systems. *Computer Networks*, 2007. doi: <https://doi.org/10.1016/j.comnet.2006.06.014>.
- [78] X. Lin, B. Hofström, E. Wang, G. Masini, H.-L. Määtänen, H. Rydén, J. Sedin, M. Stattin, O. Liberg, S. Euler, S. Muruganathan, S. Eriksson, and T. Khan. 5G New Radio Evolution Meets Satellite Communications: Opportunities, Challenges, and Solutions. *Computer Science*, 2019. URL [arXiv:1903.11219](https://arxiv.org/abs/1903.11219).
- [79] M. Corici, K. Liolis, C. Politis, A. Geurt, J. Cahill, S. Bunyan, T. Schlichter, F. Völk, and A. Kapovits. Satellite is 5G. *SATIS5 White Paper*, 2020. URL <https://artes.esa.int/projects/satis5-0>.
- [80] K. Liolis, A. Geurtz, R. Sperber, D. Schulz, S. Watts, G. Poziopoulou, B. Evans, N. Wang, O. Vidal, B. T. Jou, M. Fitch, S. D. Sendra, P. S. Khodashenas, and N. Chuberre. Use Cases and Scenarios of 5G Integrated Satellite–Terrestrial Networks for Enhanced Mobile Broadband: The SaT5G Approach. *International Journal of Satellite Communications and Networking*, 2018.
- [81] 5GPPP. 5G Infrastructure Public Private Partnership. <https://5g-ppp.eu>.

- [82] A. Guidotti, A. Vanelli-Coralli, M. Conti, S. Andrenacci, S. Chatzinotas, N. Maturo, B. Evans, A. Awoseyila, A. Ugolini, T. Foggi, L. Gaudio, N. Alagha, and S. Cioni. Architectures and Key Technical Challenges for 5G Systems Incorporating Satellites. *IEEE Transactions on Vehicular Technology*, 68(3):2624–2639, 2019. doi: 10.1109/TVT.2019.2895263.
- [83] E. Zeydan and Y. Turk. On the Impact of Satellite Communications Over Mobile Networks: An Experimental Analysis. *IEEE Transactions on Vehicular Technology*, 68(11):11146–11157, 2019. doi: 10.1109/TVT.2019.2932446.
- [84] N. Kato, Z. M. Fadlullah, F. Tang, B. Mao, S. Tani, A. Okamura, and J. Liu. Optimizing Space-Air-Ground Integrated Networks by Artificial Intelligence. *IEEE Wireless Communications*, 26(4):140–147, 2019. doi: 10.1109/MWC.2018.1800365.
- [85] B. Di, L. Song, Y. Li, and H. V. Poor. Ultra-Dense LEO: Integration of Satellite Access Networks into 5G and Beyond. *IEEE Wireless Communications*, 26(2):62–69, 2019. doi: 10.1109/MWC.2019.1800301.
- [86] G. Araniti, A. Iera, A. Molinaro, F. Rinaldi, and P. Scopelliti. Exploiting Multicast Subgrouping for Multi-Layer Video Services in 5G Satellite Networks. In *2018 IEEE Global Communications Conference (GLOBECOM)*, pages 1–6, 2018. doi: 10.1109/GLOCOM.2018.8647430.
- [87] G. Giambene, D. K. Luong, T. de Cola, V. A. Le, and M. Muhammad. Analysis of a Packet-Level Block Coding Approach for Terrestrial-Satellite Mobile Systems. *IEEE Transactions on Vehicular Technology*, 68(8):8117–8132, 2019. doi: 10.1109/TVT.2019.2925187.
- [88] O. Kodheli, S. Andrenacci, N. Maturo, S. Chatzinotas, and F. Zimmer. An Uplink UE Group-Based Scheduling Technique for 5G mMTC Systems Over LEO Satellite. *IEEE Access*, 7:67413–67427, 2019. doi: 10.1109/ACCESS.2019.2918581.
- [89] I. D. Moscholios, V. G. Vassilakis, N. C. Sagias, and M. D. Logothetis. On Channel Sharing Policies in LEO Mobile Satellite Systems. *IEEE Transactions on Aerospace and Electronic Systems*, 54(4):1628–1640, 2018. doi: 10.1109/TAES.2018.2798318.
- [90] C. Duan, J. Feng, H. Chang, B. Song, and Z. Xu. A Novel Handover Control Strategy Combined with Multi-hop Routing in LEO Satellite Networks. In *2018 IEEE International Parallel and Distributed Processing Symposium Workshops (IPDPSW)*, pages 845–851, 2018. doi: 10.1109/IPDPSW.2018.00132.
- [91] D. Wang, Y. Wang, S. Dong, G. Huang, J. Liu, and W. Gao. Exploiting Dual Connectivity for Handover Management in Heterogeneous Aeronautical Network. *IEEE Access*, 7:62938–62949, 2019. doi: 10.1109/ACCESS.2019.2916920.
- [92] Y. Bi, G. Han, S. Xu, X. Wang, C. Lin, Z. Yu, and P. Sun. Software Defined Space-Terrestrial Integrated Networks: Architecture, Challenges, and Solutions. *IEEE Network*, 33(1):22–28, 2019. doi: 10.1109/MNET.2018.1800193.

- [93] ITU-T. Series Y: Global Information Infrastructure, Internet Protocol Aspects and Next-Generation Networks, Framework of Software-Defined Networking. Report ITU-T Y.3300, 2014.
- [94] G. Giambene, S. Kota, and P. Pillai. Satellite-5G Integration: A Network Perspective. *IEEE Network*, 32(5):25–31, 2018. doi: 10.1109/MNET.2018.1800037.
- [95] ITU-T. Series Y: Global Information Infrastructure, Internet Protocol Aspects, Next-Generation Networks, Internet of Things and Smart Cities, High-level Technical Characteristics of Network Softwarization for IMT-2020. Report ITU-T Y.3150, 2018.
- [96] B. Li, Z. Fei, Z. Chu, F. Zhou, K. Wong, and P. Xiao. Robust Chance-Constrained Secure Transmission for Cognitive Satellite-Terrestrial Networks. *IEEE Transactions on Vehicular Technology*, 67(5):4208–4219, 2018. doi: 10.1109/TVT.2018.2791859.
- [97] K. An, M. Lin, J. Ouyang, and W. Zhu. Secure Transmission in Cognitive Satellite Terrestrial Networks. *IEEE Journal on Selected Areas in Communications*, 34(11):3025–3037, 2016. doi: 10.1109/JSAC.2016.2615261.
- [98] B. Li, Z. Fei, X. Xu, and Z. Chu. Resource Allocations for Secure Cognitive Satellite-Terrestrial Networks. *IEEE Wireless Communications Letters*, 7(1):78–81, 2018. doi: 10.1109/LWC.2017.2755014.
- [99] J. Xiong, D. Ma, H. Zhao, and F. Gu. Secure Multicast Communications in Cognitive Satellite-Terrestrial Networks. *IEEE Communications Letters*, 23(4):632–635, 2019. doi: 10.1109/LCOMM.2019.2903054.
- [100] J. Du, C. Jiang, H. Zhang, X. Wang, Y. Ren, and M. Debbah. Secure Satellite-Terrestrial Transmission Over Incumbent Terrestrial Networks via Cooperative Beamforming. *IEEE Journal on Selected Areas in Communications*, 36(7):1367–1382, 2018. doi: 10.1109/JSAC.2018.2824623.
- [101] V. Bankey and P. K. Upadhyay. Physical Layer Security of Multiuser Multirelay Hybrid Satellite-Terrestrial Relay Networks. *IEEE Transactions on Vehicular Technology*, 68(3): 2488–2501, 2019. doi: 10.1109/TVT.2019.2893366.
- [102] K. An and T. Liang. Hybrid Satellite-Terrestrial Relay Networks With Adaptive Transmission. *IEEE Transactions on Vehicular Technology*, 68(12):12448–12452, 2019. doi: 10.1109/TVT.2019.2944883.
- [103] K. Guo, K. An, B. Zhang, Y. Huang, and D. Guo. Physical Layer Security for Hybrid Satellite Terrestrial Relay Networks With Joint Relay Selection and User Scheduling. *IEEE Access*, 6:55815–55827, 2018. doi: 10.1109/ACCESS.2018.2872718.
- [104] D. He, X. Li, S. Chan, J. Gao, and M. Guizani. Security Analysis of a Space-Based Wireless Network. *IEEE Network*, 33(1):36–43, 2019. doi: 10.1109/MNET.2018.1800194.
- [105] Z. Chen, D. Guo, G. Ding, X. Tong, H. Wang, and X. Zhang. Optimized Power Control Scheme for Global Throughput of Cognitive Satellite-Terrestrial Networks Based on Non-Cooperative Game. *IEEE Access*, 7:81652–81663, 2019. doi: 10.1109/ACCESS.2019.2920428.

- [106] O. Y. Kolawole, S. Vuppala, M. Sellathurai, and T. Ratnarajah. On the Performance of Cognitive Satellite-Terrestrial Networks. *IEEE Transactions on Cognitive Communications and Networking*, 3(4):668–683, 2017. doi: 10.1109/TCCN.2017.2763619.
- [107] X. Yan, K. An, T. Liang, G. Zheng, and Z. Feng. Effect of Imperfect Channel Estimation on the Performance of Cognitive Satellite Terrestrial Networks. *IEEE Access*, 7:126293–126304, 2019. doi: 10.1109/ACCESS.2019.2939165.
- [108] Y. Zhao, L. Xie, H. Chen, and K. Wang. Ergodic Channel Capacity Analysis of Downlink in the Hybrid Satellite-Terrestrial Cooperative System. *Wireless Personal Communications*, 2017.
- [109] M. K. Arti and V. Jain. Relay Selection-based Hybrid Satellite-Terrestrial Communication System. *IET Communications*, 2017.
- [110] Z. Ding, X. Lei, G. K. Karagiannidis, R. Schober, J. Yuan, and V. K. Bhargava. A Survey on Non-Orthogonal Multiple Access for 5G Networks: Research Challenges and Future Trends. *IEEE Journal on Selected Areas in Communications*, 35(10):2181–2195, 2017. doi: 10.1109/JSAC.2017.2725519.
- [111] L. Bai, L. Zhu, X. Zhang, W. Zhang, and Q. Yu. Multi-Satellite Relay Transmission in 5G: Concepts, Techniques, and Challenges. *IEEE Network*, 32(5):38–44, 2018. doi: 10.1109/MNET.2018.1800038.
- [112] X. Yan, H. Xiao, K. An, G. Zheng, and S. Chatzinotas. Ergodic Capacity of NOMA-Based Uplink Satellite Networks With Randomly Deployed Users. *IEEE Systems Journal*, 14(3):3343–3350, 2020. doi: 10.1109/JSYST.2019.2934358.
- [113] X. Yan, H. Xiao, K. An, G. Zheng, and W. Tao. Hybrid Satellite Terrestrial Relay Networks With Cooperative Non-Orthogonal Multiple Access. *IEEE Communications Letters*, 22(5):978–981, 2018. doi: 10.1109/LCOMM.2018.2815610.
- [114] X. Zhang, B. Zhang, K. An, Z. Chen, S. Xie, H. Wang, L. Wang, and D. Guo. Outage Performance of NOMA-Based Cognitive Hybrid Satellite-Terrestrial Overlay Networks by Amplify-and-Forward Protocols. *IEEE Access*, 7:85372–85381, 2019. doi: 10.1109/ACCESS.2019.2925314.
- [115] X. Zhu, C. Jiang, L. Kuang, N. Ge, and J. Lu. Non-Orthogonal Multiple Access Based Integrated Terrestrial-Satellite Networks. *IEEE Journal on Selected Areas in Communications*, 35(10):2253–2267, 2017. doi: 10.1109/JSAC.2017.2724478.
- [116] Z. Lin, M. Lin, J. Wang, T. de Cola, and J. Wang. Joint Beamforming and Power Allocation for Satellite-Terrestrial Integrated Networks With Non-Orthogonal Multiple Access. *IEEE Journal of Selected Topics in Signal Processing*, 13(3):657–670, 2019. doi: 10.1109/JSTSP.2019.2899731.
- [117] F. Rinaldi, H. Määttänen, J. Torsner, S. Pizzi, S. Andreev, A. Iera, Y. Koucheryavy, and G. Araniti. Broadcasting Services Over 5G NR Enabled Multi-Beam Non-Terrestrial Networks. *IEEE Transactions on Broadcasting*, pages 1–13, 2020. doi: 10.1109/TBC.2020.2991312.

- [118] I. F. Akyldiz and A. Kak. The Internet of Space Things/CubeSats: A Ubiquitous Cyber-Physical System for the Connected World. *Computer Networks*, 2019. doi: <https://doi.org/10.1016/j.comnet.2018.12.017>.
- [119] Z. Qu, G. Zhang, H. Cao, and J. Xie. LEO Satellite Constellation for Internet of Things. *IEEE Access*, 5:18391–18401, 2017. doi: 10.1109/ACCESS.2017.2735988.
- [120] K. Woellert, P. Ehrenfreund, A. J. Ricco, and H. Hertzfeld. CubeSats: Cost-Effective Science and Technology Platforms for Emerging and Developing Nations. *Advances in Space Research Journal*, 2011. doi: <https://doi.org/10.1016/j.asr.2010.10.009>.
- [121] V. Almonacid and F. Laurent. Extending the Coverage of the Internet of Things with Low-Cost Nanosatellite Networks. *Acta Astronautica*, 2017. doi: <https://doi.org/10.1016/j.actaastro.2017.05.030>.
- [122] J. Puig-Suari, C. Turner, and W. Ahlgren. Development of the standard CubeSat deployer and a CubeSat class PicoSatellite. In *2001 IEEE Aerospace Conference Proceedings (Cat. No.01TH8542)*, volume 1, pages 1/347–1/353 vol.1, 2001. doi: 10.1109/AERO.2001.931726.
- [123] I. F. Akyldiz, J. M. Jornet, and S. Nie. A new CubeSat Design with Reconfigurable Multi-Band Radios for Dynamic Spectrum Satellite Communication Networks. *Ad Hoc Networks*, 2019. doi: <https://doi.org/10.1016/j.adhoc.2018.12.004>.
- [124] L. Bertaux, S. Medjiah, P. Berthou, S. Abdellatif, A. Hakiri, P. Gelard, F. Planchou, and M. Bruyere. Software Defined Networking and Virtualization for Broadband Satellite Networks. *IEEE Communications Magazine*, 53(3):54–60, 2015. doi: 10.1109/MCOM.2015.7060482.
- [125] T. Li, H. Zhou, H. Luo, Q. Xu, and Y. Ye. Using SDN and NFV to Implement Satellite Communication Networks. In *2016 International Conference on Networking and Network Applications (NaNA)*, pages 131–134, 2016. doi: 10.1109/NaNA.2016.22.
- [126] R. Ferrus, H. Koumaras, O. Sallent, T. Rasheed, E. Duros, R. Riggio, N. Kuhn, P. Gelard, and T. Ahmed. On the Virtualization and Dynamic Orchestration of Satellite Communication Services. In *2016 IEEE 84th Vehicular Technology Conference (VTC-Fall)*, pages 1–5, 2016. doi: 10.1109/VTCFall.2016.7881129.
- [127] Y. C. Hu, M. Patel, D. Sabella, N. Sprecher, and V. Young. Mobile Edge Computing a Key Technology Towards 5G. ETSI White Paper No. 11, 2015.
- [128] L. Yan, S. Cao, Y. Gong, H. Han, J. Wei, Y. Zhao, and S. Yang. SatEC: A 5G Satellite Edge Computing Framework Based on Microservice Architecture. *Sensors*, 2019. doi: <https://doi.org/10.3390/s19040831>.
- [129] C. Suzhi, W. Junyong, H. Hao, Z. Yi, Y. Shuling, Y. Lei, W. Shaojun, and G. Yongsheng. Space Edge Cloud Enabling Network Slicing for 5G Satellite Network. In *2019 15th International Wireless Communications Mobile Computing Conference (IWCMC)*, pages 787–792, 2019. doi: 10.1109/IWCMC.2019.8766619.

- [130] 3GPP. TS 36.300; Evolved Universal Terrestrial Radio Access (E-UTRA) and Evolved Universal Terrestrial Radio Access Network (E-UTRAN); Rel.16. Technical Specification; 3GPP, 2020.
- [131] M. De Sanctis, E. Cianca, G. Araniti, I. Bisio, and R. Prasad. Satellite Communications Supporting Internet of Remote Things. *IEEE Internet of Things Journal*, 3(1):113–123, 2016. doi: 10.1109/JIOT.2015.2487046.
- [132] M. LiWang, S. Dai, Z. Gao, X. Du, M. Guizani, and H. Dai. A Computation Offloading Incentive Mechanism with Delay and Cost Constraints under 5G Satellite-Ground IoV Architecture. *IEEE Wireless Communications*, 26(4):124–132, 2019. doi: 10.1109/MWC.2019.1800364.
- [133] ITU-T. Series Y: Global Information Infrastructure, Internet Protocol Aspects, Next-Generation Networks, Internet of Things and Smart Cities, Framework of the IMT-2020 network. Report ITU-T Y.3102, 2018.
- [134] G. Araniti, G. Genovese, A. Iera, A. Molinaro, and S. Pizzi. Virtualizing Nanosatellites in SDN/NFV Enabled Ground Segments to Enhance Service Orchestration. In *2019 IEEE Global Communications Conference (GLOBECOM)*, pages 1–6, 2019. doi: 10.1109/GLOBECOM38437.2019.9013347.
- [135] 3GPP. TS 22.261; Service requirements for the 5G system; Rel. 17. Technical Specification, 3GPP, 2020.
- [136] 3GPP. TR 23.737; Study on architecture aspects for using satellite access in 5G; Rel.17. Technical report, 3GPP, 2019.
- [137] 3GPP. TR 28.808; Study on management and orchestration aspects with integrated satellite components in a 5G network; Rel.16. Technical report, 3GPP, 2020.
- [138] H.-L. Määttänen, B. Hofstrom, S. Euler, J. Sedin, X. Lin, O. Liberg, G. Masini, and M. Israelsson. 5G NR Communication over GEO or LEO Satellite Systems: 3GPP RAN Higher Layer Standardization Aspects. In *2019 IEEE Global Communications Conference (GLOBECOM)*, pages 1–6, 2019. doi: 10.1109/GLOBECOM38437.2019.9014090.
- [139] Y. Wu, G. Hu, F. Jin, and J. Zu. A Satellite Handover Strategy Based on the Potential Game in LEO Satellite Networks. *IEEE Access*, 7:133641–133652, 2019. doi: 10.1109/ACCESS.2019.2941217.
- [140] X. Zhang, K. Shi, S. Zhang, D. Li, and R. Xia. Virtual Agent Clustering Based Mobility Management Over the Satellite Networks. *IEEE Access*, 7:89544–89555, 2019. doi: 10.1109/ACCESS.2019.2926432.
- [141] X. Hu, H. Song, S. Liu, and W. Wang. Velocity-Aware Handover Prediction in LEO Satellite Communication Networks. *International Journal of Satellite Communications and Networking*, 36(6):451–459, 2018. doi: 10.1002/sat.1250.
- [142] Z. Hou, X. Yi, Y. Zhang, Y. Kuang, and Y. Zhao. Satellite-Ground Link Planning for LEO Satellite Navigation Augmentation Networks. *IEEE Access*, 7:98715–98724, 2019. doi: 10.1109/ACCESS.2019.2930626.

- [143] X. Yan, K. An, T. Liang, G. Zheng, and Z. Feng. Effect of Imperfect Channel Estimation on the Performance of Cognitive Satellite Terrestrial Networks. *IEEE Access*, 7:126293–126304, 2019. doi: 10.1109/ACCESS.2019.2939165.
- [144] S. Xie, B. Zhang, D. Guo, and B. Zhao. Performance Analysis and Power Allocation for NOMA-Based Hybrid Satellite-Terrestrial Relay Networks With Imperfect Channel State Information. *IEEE Access*, 7:136279–136289, 2019. doi: 10.1109/ACCESS.2019.2942167.
- [145] M. K. Arti. Imperfect CSI Based Multi-Way Satellite Relaying. *IEEE Wireless Communications Letters*, 7(5):864–867, 2018. doi: 10.1109/LWC.2018.2833471.
- [146] M. À. Vázquez, A. Perez-Neira, D. Christopoulos, S. Chatzinotas, B. Ottersten, P. Arapoglou, A. Ginesi, and G. Tarocco. Precoding in Multibeam Satellite Communications: Present and Future Challenges. *IEEE Wireless Communications*, 23(6):88–95, 2016. doi: 10.1109/MWC.2016.1500047WC.
- [147] W. Wang, A. Liu, Q. Zhang, L. You, X. Gao, and G. Zheng. Robust Multigroup Multicast Transmission for Frame-Based Multi-Beam Satellite Systems. *IEEE Access*, 6:46074–46083, 2018. doi: 10.1109/ACCESS.2018.2865998.
- [148] D. Christopoulos, S. Chatzinotas, and B. Ottersten. Multicast Multigroup Precoding and User Scheduling for Frame-Based Satellite Communications. *IEEE Transactions on Wireless Communications*, 14(9):4695–4707, 2015. doi: 10.1109/TWC.2015.2424961.
- [149] A. Guidotti and A. Vanelli-Coralli. Clustering Strategies for Multicast Precoding in Multibeam Satellite Systems. *International Journal of Satellite Communications and Networking*, 38(2):85–104, 2020. doi: 10.1002/sat.1312.
- [150] A. Guidotti and A. Vanelli-Coralli. Geographical Scheduling for Multicast Precoding in Multi-Beam Satellite Systems. In *2018 9th Advanced Satellite Multimedia Systems Conference and the 15th Signal Processing for Space Communications Workshop (ASMS/SPSC)*, pages 1–8, 2018. doi: 10.1109/ASMS-SPSC.2018.8510728.
- [151] A. Paris, I. Del Portillo, B. Cameron, and E. Crawley. A Genetic Algorithm for Joint Power and Bandwidth Allocation in Multibeam Satellite Systems. In *2019 IEEE Aerospace Conference*, pages 1–15, 2019. doi: 10.1109/AERO.2019.8742238.
- [152] M. Takahashi, Y. Kawamoto, N. Kato, A. Miura, and M. Toyoshima. Adaptive Power Resource Allocation With Multi-Beam Directivity Control in High-Throughput Satellite Communication Systems. *IEEE Wireless Communications Letters*, 8(4):1248–1251, 2019. doi: 10.1109/LWC.2019.2912753.
- [153] A. B. Kihero, M. S. J. Solaija, and H. Arslan. Inter-Numerology Interference for Beyond 5G. *IEEE Access*, 7:146512–146523, 2019. doi: 10.1109/ACCESS.2019.2946084.
- [154] A. B. Kihero, M. S. J. Solaija, A. Yazar, and H. Arslan. Inter-Numerology Interference Analysis for 5G and Beyond. In *2018 IEEE Globecom Workshops (GC Wkshps)*, pages 1–6, 2018. doi: 10.1109/GLOCOMW.2018.8644394.
- [155] X. Zhang, L. Zhang, P. Xiao, D. Ma, J. Wei, and Y. Xin. Mixed Numerologies Interference Analysis and Inter-Numerology Interference Cancellation for Windowed

- OFDM Systems. *IEEE Transactions on Vehicular Technology*, 67(8):7047–7061, 2018. doi: 10.1109/TVT.2018.2826047.
- [156] 3GPP. RP-193234, Solutions for NR to support Non-Terrestrial Networks (NTN). 3GPP TSG RAN meeting no. 86, 2019.
- [157] 3GPP. RP-193235, New Study WID on NB-IoT/eMTC support for NTN. 3GPP TSG RAN meeting no. 86, 2019.
- [158] ITU. ITU FG-NET-2030, Network 2030 A Blueprint of Technology, Applications and Market Drivers Towards the Year 2030 and Beyond. ITU White Papers, 2019.
- [159] M. Mozaffari, A. T. Z. Kasgari, W. Saad, M. Bennis, and M. Debbah. Beyond 5G With UAVs: Foundations of a 3D Wireless Cellular Network. *IEEE Transactions on Wireless Communications*, 18(1):357–372, 2019. doi: 10.1109/TWC.2018.2879940.
- [160] X. Cao, S. Kim, K. Obraczka, C. Wang, D. O. Wu, and H. Yanikomeroglu. Guest Editorial Airborne Communication Networks. *IEEE Journal on Selected Areas in Communications*, 36(9):1903–1906, 2018. doi: 10.1109/JSAC.2018.2871519.
- [161] B. Zong, C. Fan, X. Wang, X. Duan, B. Wang, and J. Wang. 6G Technologies: Key Drivers, Core Requirements, System Architectures, and Enabling Technologies. *IEEE Vehicular Technology Magazine*, 14(3):18–27, 2019. doi: 10.1109/MVT.2019.2921398.
- [162] W. Saad, M. Bennis, and M. Chen. A Vision of 6G Wireless Systems: Applications, Trends, Technologies, and Open Research Problems. *IEEE Network*, 34(3):134–142, 2020. doi: 10.1109/MNET.001.1900287.
- [163] D. Gómez-Barquero, C. Douillard, P. Moss, and V. Mignone. DVB-NGH: The Next Generation of Digital Broadcast Services to Handheld Devices. *IEEE Transactions on Broadcasting*, 60(2):246–257, 2014. doi: 10.1109/TBC.2014.2313073.
- [164] 3GPP. TR 25.905; Technical Specification Group Radio Access Network; Improvement of the Multimedia Broadcast Multicast Service (MBMS) in UTRAN, Rel.7. Technical report, 3GPP, 2007.
- [165] 3GPP. TS 38.913, Study on Scenarios and Requirements for Next Generation Access Technologies, Rel.15. Technical Specification, 3GPP, 2018.
- [166] J. J. Gimenez, J. L. Carcel, M. Fuentes, E. Garro, S. Elliott, D. Vargas, C. Menzel, and D. Gómez-Barquero. 5G New Radio for Terrestrial Broadcast: A Forward-Looking Approach for NR-MBMS. *IEEE Transactions on Broadcasting*, 65(2):356–368, 2019. doi: 10.1109/TBC.2019.2912117.
- [167] A. Sali, H. A. Karim, G. Acar, B. Evans, and G. Giambene. Multicast Link Adaptation in Reliable Transmission Over Geostationary Satellite Networks. *Wireless Personal Communications*, 2012.
- [168] G. Aiyetoro, G. Giambene, and F. Takawira. Link Adaptation in Satellite LTE Networks. *Journal of Advances in Information Technology*, 2014.
- [169] G. Araniti, I. Bisio, M. De Sanctis, A. Orsino, and J. Cosmas. Multimedia Content Delivery for Emerging 5G-Satellite Networks. *IEEE Transactions on Broadcasting*, 62(1):10–23, 2016. doi: 10.1109/TBC.2015.2511625.

- [170] K. Nakahira, K. Kobayashi, and M. Ueba. A Resource Allocation Scheme for QoS Provision in Multi-beam Mobile Satellite Communication Systems. In *2007 IEEE Wireless Communications and Networking Conference*, pages 4008–4012, 2007. doi: 10.1109/WCNC.2007.732.
- [171] H. Chaouech and R. Bouallegue. Channel Estimation and Detection for Multibeam Satellite Communications. In *2010 IEEE Asia Pacific Conference on Circuits and Systems*, pages 366–369, 2010. doi: 10.1109/APCCAS.2010.5775068.
- [172] S. Liu, X. Hu, and W. Wang. Deep Reinforcement Learning Based Dynamic Channel Allocation Algorithm in Multibeam Satellite Systems. *IEEE Access*, 6:15733–15742, 2018. doi: 10.1109/ACCESS.2018.2809581.
- [173] G. Zheng, S. Chatzinotas, and B. Ottersten. Generic Optimization of Linear Precoding in Multibeam Satellite Systems. *IEEE Transactions on Wireless Communications*, 11(6): 2308–2320, 2012. doi: 10.1109/TWC.2012.040412.111629.
- [174] V. Joroughi, M. À. Vázquez, and A. I. Pérez-Neira. Generalized Multicast Multibeam Precoding for Satellite Communications. *IEEE Transactions on Wireless Communications*, 16(2):952–966, 2017. doi: 10.1109/TWC.2016.2635139.
- [175] F. P. Fontán, M. À. Vázquez-Castro, C. E. Cabado, J. P. Garcia, and E. Kubista. Statistical Modeling of the LMS Channel. *IEEE Transactions on Vehicular Technology*, 50(6):1549–1567, 2001. doi: 10.1109/25.966585.
- [176] C. Loo. A Statistical Model for a Land Mobile Satellite Link. *IEEE Transactions on Vehicular Technology*, 34(3):122–127, 1985. doi: 10.1109/T-VT.1985.24048.
- [177] J. Liu, W. Chen, Z. Cao, and K. B. Letaief. Dynamic Power and Sub-Carrier Allocation for OFDMA-Based Wireless Multicast Systems. In *2008 IEEE International Conference on Communications*, pages 2607–2611, 2008. doi: 10.1109/ICC.2008.494.
- [178] T. Low, M. Pun, Y.-W. Peter Hong, and C.-C. Jay Kuo. Optimized Opportunistic Multicast Scheduling (OMS) over Wireless Cellular Networks. *IEEE Transactions on Wireless Communications*, 9(2):791–801, 2010. doi: 10.1109/TWC.2010.02.090387.
- [179] G. Araniti, F. Rinaldi, P. Scopelliti, A. Molinaro, and A. Iera. A Dynamic MBSFN Area Formation Algorithm for Multicast Service Delivery in 5G NR Networks. *IEEE Transactions on Wireless Communications*, 19(2):808–821, 2020. doi: 10.1109/TWC.2019.2948846.
- [180] F. Rinaldi, S. Pizzi, A. Orsino, A. Iera, A. Molinaro, and G. Araniti. A Novel Approach for MBSFN Area Formation Aided by D2D Communications for eMBB Service Delivery in 5G NR Systems. *IEEE Transactions on Vehicular Technology*, 69(2):2058–2070, 2020. doi: 10.1109/TVT.2019.2958424.
- [181] X. Wang, H. Li, M. Tong, K. Pan, and Q. Wu. Network Coded Cooperative Multicast in Integrated Terrestrial-Satellite Networks. In *2019 IEEE Symposium on Computers and Communications (ISCC)*, pages 1–6, 2019. doi: 10.1109/ISCC47284.2019.8969770.

- [182] Y. Zhang, L. Yin, C. Jiang, and Y. Qian. Joint Beamforming Design and Resource Allocation for Terrestrial-Satellite Cooperation System. *IEEE Transactions on Communications*, 68(2):778–791, 2020. doi: 10.1109/TCOMM.2019.2950022.
- [183] B. Deng, C. Jiang, J. Yan, N. Ge, S. Guo, and S. Zhao. Joint Multigroup Precoding and Resource Allocation in Integrated Terrestrial-Satellite Networks. *IEEE Transactions on Vehicular Technology*, 68(8):8075–8090, 2019. doi: 10.1109/TVT.2019.2924669.
- [184] F. Rinaldi, H. Määttänen, J. Torsner, S. Pizzi, S. Andreev, A. Iera, Y. Koucheryavy, and G. Araniti. Non-Terrestrial Networks in 5G & Beyond: A Survey. *IEEE Access*, 8: 165178–165200, 2020. doi: 10.1109/ACCESS.2020.3022981.
- [185] 3GPP. TS 36.211; Evolved Universal Terrestrial Radio Access (E-UTRA); Physical channels and modulation; Rel. 16. Technical Specification, 3GPP, 2020.
- [186] 3GPP. TR 36.763; Study on Narrow-Band Internet of Things (NB-IoT)/enhanced Machine Type Communication (eMTC) support for Non-Terrestrial Networks (NTN); created for Rel.17. Technical report, 3GPP.



---

## List of Publications

- [P1] D. Ostriкова, F. Rinaldi, V. Beschastnyi, I. Gudkova, L. Militano, G. Araniti, A. Iera, and K. Samouylov. Analytical Model for Multicast Subgrouping in 5G-Mobile eMBMS Environment. In *2017 9th International Congress on Ultra Modern Telecommunications and Control Systems and Workshops (ICUMT)*, pages 13–19, 2017.
- [P2] G. Araniti, I. Bisio, M. De Sanctis, F. Rinaldi, and A. Sciarrone. Joint Coding and Multicast Subgrouping Over Satellite-eMBMS Networks. *IEEE Journal on Selected Areas in Communications*, 36(5):1004–1016, 2018.
- [P3] F. Rinaldi, P. Scopelliti, A. Iera, A. Molinaro, and G. Araniti. Delivering Multimedia Services in MBSFN Areas Over 5G Networks: A Performance Analysis. In *2018 IEEE International Symposium on Broadband Multimedia Systems and Broadcasting (BMSB)*, pages 1–5, Valencia, Spain, 2018.
- [P4] S. Pizzi, F. Rinaldi, A. Molinaro, A. Iera, and G. Araniti. Energy-Efficient Multicast Service Delivery Exploiting Single Frequency Device-To-Device Communications in 5G New Radio Systems. *Sensors*, 18(7):2205, 2018.
- [P5] S. Pizzi, F. Rinaldi, M. Fadda, and G. Araniti. Performance Evaluation of D2D-based SFN for Multicast Service Delivery in 5G Networks. In *2018 Baltic URSI Symposium (URSI)*, pages 75–79, 2018.
- [P6] G. Araniti, A. Iera, A. Molinaro, F. Rinaldi, and P. Scopelliti. Exploiting Multicast Subgrouping for Multi-Layer Video Services in 5G Satellite Networks. In *2018 IEEE Global Communications Conference (GLOBECOM)*, pages 1–6, 2018.
- [P7] G. Araniti, F. Rinaldi, P. Scopelliti, A. Molinaro, and A. Iera. A Dynamic MBSFN Area Formation Algorithm for Multicast Service Delivery in 5G NR Networks. *IEEE Transactions on Wireless Communications*, 19(2):808–821, 2020.
- [P8] F. Rinaldi, S. Pizzi, A. Orsino, A. Iera, A. Molinaro, and G. Araniti. A Novel Approach for MBSFN Area Formation Aided by D2D Communications for eMBB Service Delivery in 5G NR Systems. *IEEE Transactions on Vehicular Technology*, 69(2):2058–2070, 2020.
- [P9] F. Rinaldi, O. Vikhrova, S. Pizzi, A. Iera, A. Molinaro, and G. Araniti. *Joint Device-to-Device and MBSFN Transmission for eMBB Service Delivery in 5G NR Networks*.

- International Conference on Next Generation Wired/Wireless Advanced Networks and Systems (NEW2AN), ruSMART 2019. Lecture Notes in Computer Science, volume 11660, pages 599–609. Springer, Cham, 2019.
- [P10] F. Rinaldi, S. Pizzi, A. Molinaro, A. Iera, and G. Araniti. Frequency Reuse Techniques for eMBB Services over 5G Multi-Beam Non-Terrestrial Networks. In *2020 IEEE International Symposium on Broadband Multimedia Systems and Broadcasting (BMSB)*, Paris, France, 2020.
- [P11] F. Rinaldi, H.-L. Määttänen, J. Torsner, S. Pizzi, S. Andreev, A. Iera, Y. Koucheryavy, and G. Araniti. Broadcasting Services Over 5G NR enabled Multi-Beam Non-Terrestrial Networks. *IEEE Transactions on Broadcasting*, pages 1–13, 2020.
- [P12] F. Rinaldi, S. Pizzi, O. Vikhrova, A. Molinaro, and G. Araniti. Paging IoT Devices in 5G-Enabled Non-Terrestrial Networks. In *71st International Astronautical Congress, IAC 2020 - the Cyberspace Edition*, 2020.
- [P13] F. Rinaldi, S. Pizzi, A. Molinaro, A. Iera, and G. Araniti. Cooperative Resource Allocation in Integrated Terrestrial/Non-Terrestrial 5G and Beyond Networks. In *2020 IEEE Global Communications Conference (GLOBECOM)*, 2020.
- [P14] F. Rinaldi, H.-L. Määttänen, J. Torsner, S. Pizzi, S. Andreev, A. Iera, Y. Koucheryavy, and G. Araniti. Non-Terrestrial Networks in 5G & Beyond: A Survey. *IEEE Access*, 2020.