



**UNIVERSITÀ DEGLI STUDI “MEDITERRANEA”
DI REGGIO CALABRIA
DIPARTIMENTO DI AGRARIA**

Dottorato in Ricerca in Scienze Agrarie, Alimentari e Forestali
Curriculum Scienze e Tecnologie Alimentari

**“Enhancement of biogas production through anaerobic
digestion of agrifood by-products and food waste”**

Tutor: Chiar.mo Prof. Giuseppe Zimbalatti

Co-tutor: Chiar.mo Prof. Bruno Bernardi

Ph.D. Coordinator: Prof. Leonardo Schena

Ph.D. Thesis

Alessandro Neri

Anno Accademico 2020-2023



Dottorato
di Ricerca
Scienze
Agrarie
Alimentari e
Forestali

**UNIVERSITÀ DEGLI STUDI "MEDITERRANEA" DI
REGGIO CALABRIA**
DIPARTIMENTO DI AGRARIA
**Dottorato di Ricerca in
Scienze Agrarie, Alimentari e Forestali**
Curriculum Scienze e Tecnologie Alimentari
Ciclo XXXVI, 2020/2023 - SSD: AGR/09

Alessandro Neri

**"Enhancement of biogas production through anaerobic
digestion of agrifood by-products and food waste"**

PH.D. THESIS

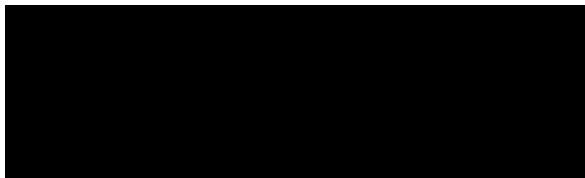

Tutor
Chiar.mo Prof. Giuseppe Zimbalatti

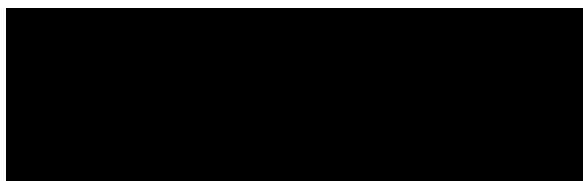

Co-Tutor
Chiar.mo Prof. Bruno Bernardi

Ph.D. Coordinator
Prof. Leonardo Schena

Reggio Calabria, 2023

RIASSUNTO.....

ABSTRACT.....

TABLE OF CONTENTS

1. INTRODUCTION	1
1.1 Importance of the environmental sustainability of biogas.....	4
1.2 Italian and European regulatory framework for biogas and biomethane.....	7
1.3 The anaerobic digestion process.....	13
2. AN OVERVIEW OF THE ANAEROBIC DIGESTION PROCESS	17
2.1 Applicable types of plant and technologies	17
2.2 Pre-digestion and acidification unit.....	20
2.3 Continuous process.....	21
2.3.1 Fully mixed continuous reactor process without recirculation (CSTR)...	22
2.3.2 Continuous reactor process with recirculation.....	23
2.3.3 Continuous process in a piston flow reactor.....	23
2.3.4 Continuous process with recirculation in a piston-flow reactor.....	24
2.3.5 Continuous process with separate phase.....	25
2.4 Wet- digestion process	26
2.5 Dry digestion process.....	28
2.6 Semi-dry digestion process.....	30
2.7 Two-stage digestion processes.....	32
2.8 Different types of batch tests.....	33
2.9 Factors influencing the anaerobic digestion process.....	39
2.9.1 Temperature and temperature effect on reaction kinetics	39

2.9.2 pH and alkalinity	42
2.9.3 Alkalinity (buffering effect)	43
2.9.4 Total Solids and Volatile Total Solids.....	44
2.9.5 Chemical Oxygen Demand (COD)	45
2.9.6 Theoretical relationship between COD and VS	46
2.9.7 Concentration of volatile fatty acids.....	47
2.9.8 Volatile fatty acid/alkalinity ratio	48
2.9.9 Ammonium.....	48
2.9.10 Total Kjeldahl Nitrogen.....	49
2.9.11 Carbon-nitrogen ratio.....	49
2.9.12 Nutrient supply.....	50
2.10 Inhibiting and degenerative factors in the anaerobic digestion process.....	51
2.11 Management parameters of the continuous anaerobic digestion process.....	53
2.12 Applications of anaerobic digestion, biogas utilisation and biogas pre-treatment.....	57
2.13 Uses of biogas.....	58
2.14 Organic substrates which can be used in the AD process.....	65
2.14.1 Livestock waste	66
2.14.2 Agricultural biomass and energy crops.....	68
2.14.3 Agri-industrial by-products and food waste.....	69
2.14.4 Sewage sludge	76
2.14.5 Organic Fraction of Municipal Solid Waste (OFMSW)	77
2.15 Choosing a biomass.....	78
2.16 The digestate and its use.....	79

2.17 Pre-treatment of agri-industrial waste.....	80
2.17.1 Particle reduction, mechanical pre-treatment.....	82
2.17.2 Ultrasound pre-treatment.....	85
2.17.3 Thermal pretreatment.....	86
2.17.4 Chemical pretreatment.....	87
2.17.5 Electrokinetic disintegration pre-treatment.....	87
2.17.6 Biological treatment.....	89
2.17.7 Combined processes.....	90
2.17.8 Steam explosion.....	90
2.17.9 Extrusion.....	90
2.17.10 Thermochemical pretreatment.....	91
2.18 Anaerobic digestion of food waste and agrifood by-products undergoing pretreatment and novelties in the experimental field.....	92
3. ANAEROBIC DIGESTION OF AGRI-INDUSTRIAL BY-PRODUCTS AND FOOD WASTE OR BIOMETHANE PRODUCTION: MATERIALS AND METHODS.....	96
3.1 Physical-chemical characterization of the matrices.....	98
3.1.1 pH determination.....	99
3.1.2 Determination of Total Solids and Total Volatile Solids.....	100
3.1.3 Ammonium nitrogen and Total Kjeldahl Nitrogen determination.....	102
3.1.4 Chemical Oxygen Demand (COD) determination.....	107
3.1.5 Determination of Total Volatile Fatty Acids by HPLC.....	111
3.1.6 Determination of Total Poliphenols.....	114
3.2 Experimental set- up	115

3.3 Continuous test set up.....	119
3.4 Statistical analysis.....	121
ACKNOWLEDGEMENT	122
REFERENCES.....	122
4.EXPERIMENTAL DESIGN N. 1: Recovery of agrifood by-products and food waste for bio-methane production.....	142
Abstract.....	142
4.1 Introduction.....	145
4.2 Materials and Methods.....	145
4.3 Physical-chemical characterization of the substrates.....	146
4.4 Experimental set-up and BMP test.....	146
4.5 Results and discussion.....	151
4.6 Treatment efficiency.....	158
4.7 Conclusions.....	163
Acknowledgement.....	164
References.....	164
5.EXPERIMENTAL DESIGN N.2: Anaerobic co-digestion of mixtures composed of two agri-industrial by-products.....	167
Abstract.....	167
5.1 Introduction.....	167
5.2 Materials and Methods.....	169
5.3 Physical-chemical characterization of the substrates.....	169
5.4 Experimental set-up and BMP test.....	170
5.5 Results and discussion.....	173

5.6 Treatment efficiency.....	179
5.7 Conclusions.....	181
References.....	182
6.EXPERIMENTAL DESIGN N.3: Anaerobic co-digestion of mixtures composed of three substrates from the dairy industry and different agri-food wastes.....	184
Abstract.....	184
6.1 Introduction.....	184
6.2 Materials and Methods.....	186
6.3 Physical-chemical characterization of the substrates.....	186
6.4 Experimental set-up and BMP test.....	187
6.5 Results and discussion.....	190
6.6 Treatment efficiency.....	194
6.7 Conclusions.....	197
References.....	198
7.EXPERIMENTAL DESIGN N. 3: Continuous anaerobic co-digestion of a mixture of dairy industry waste and meat products using CSTR reactors fed daily.....	200
Abstract.....	200
7.1 Introduction.....	200
7.2 Materials and Methods.....	202
7.3 The CSTR reactors.....	203
7.4 Experimental set-up.....	204
7.5 Results and discussion.....	210
7.7 Conclusions.....	224

References.....	225
8.CONCLUSIONS AND FUTURE PERSPECTIVES.....	230

IMAGE INDEX

<i>Figure 1 Flow chart of anaerobic digestion.....</i>	<i>14</i>
<i>Figure 2.1 One-stage and two-stage AD process.....</i>	<i>21</i>
<i>Figure 2.2 Full mixing reactor without recycling diagram.....</i>	<i>22</i>
<i>Figure 2.3 Continuous process with recirculation in a piston-flow reactor.....</i>	<i>24</i>
<i>Figure 2.4 Typical single-stage wet process diagram.....</i>	<i>27</i>
<i>Figure 2.5 Test apparatus according to DIN 38414-8: Gas volume measurement with the eudiometer tube.....</i>	<i>35</i>
<i>Figure 2.6 Test apparatus according to DIN EN ISO 11734: Gas volume measurement.....</i>	<i>35</i>
<i>Figure 2.7 Test apparatus→ Gas volume measurement with gas sampling tube..</i>	<i>36</i>
<i>Figure 2.8 Gas volume measurement using gas- bags.....</i>	<i>37</i>
<i>Figure 2.9 Schematic diagram of the Hohenheim fermentation test.....</i>	<i>37</i>
<i>Figure 2.10 Gas volume measurement with the micro gas meter.....</i>	<i>38</i>
<i>Figure 2.11 Influence of temperature on biological kinetics.....</i>	<i>41</i>
<i>Figure 2.12 Classification of livestock manure according to the percentage of total solids.....</i>	<i>67</i>
<i>Figure 2.13 An example of a hammer mill for size reduction.....</i>	<i>83</i>
<i>Figure 2.14 Example of multi-sieve vibrator with gradually finer sieve sizes.....</i>	<i>84</i>
<i>Figure 2.15 Reversible and irreversible electroporation.....</i>	<i>88</i>
<i>Figure 2.16 Image simplifying the operation of the BioCrack.....</i>	<i>88</i>
<i>Figure 2.17 BioCrack instrument.....</i>	<i>89</i>
<i>Figure 2.18 Extrusion equipment and plant waste undergoing the extrusion process.....</i>	<i>90</i>
<i>Figure 3.1 Fresh samples to be dried at 105°C.</i>	<i>100</i>
<i>Figure 3.2 Sample preparation for ammonium and TKN analysis.....</i>	<i>102</i>

<i>Figure 3.3 Samples subjected to thermal cycling for TKN analysis.....</i>	<i>103</i>
<i>Figure 3.4 Samples thermally cycled 180 minutes at 150°C.....</i>	<i>108</i>
<i>Figure 3.5 Diluted samples.....</i>	<i>108</i>
<i>Figure 3.6 Metrohm 87G Dosimat plus used for sample titration.....</i>	<i>109</i>
<i>Figure 3.7 Post-titration sample staining.....</i>	<i>109</i>
<i>Figure 3.8 Samples ready for injection into HPLC for tVFA analysis.....</i>	<i>111</i>
<i>Figure 3.9 HPLC Agilent 1100.</i>	<i>112</i>
<i>Figure 3.10 Weighing of samples directly into the reactors and addition of inoculum.....</i>	<i>116</i>
<i>Figure 3.11 Setting up the reactors.....</i>	<i>117</i>
<i>Figure 3.12 Climate cell set at a temperature of 37 °C to favour the mesophilic environment.....</i>	<i>117</i>
<i>Figure 3.13 Reactor set-up.....</i>	<i>120</i>
<i>Figure 4.1 Graphical set-up of the BMP test with water displacement method for biomethane quantitation.</i>	<i>147</i>
<i>Figure 4.2 Reactors placed inside the climatic chamber at 37 °C.....</i>	<i>147</i>
<i>Figure 4.3 Production of $NL_{methane} \cdot gVS^{-1}$ for the trial weeks. Data marked with different capital letters are significantly different by Tukey's test ($p < 0.05$).....</i>	<i>155</i>
<i>Figure 4.4 The graph shows that the most productive theses were 7 and 4 (C), with a production of $2675.99 \pm 3.90 NL_{methane}$ and $2653.08 \pm 20.13 NL_{methane}$ respectively. The least productive theses were 9-6-8 (B). While the others had an intermediate production (BC). Data marked with different capital letters are significantly different according to Tukey's test ($p < 0.05$).....</i>	<i>156</i>
<i>Figure 4.5 The graph shows that the most productive theses were 7 and 4 (C), with a production of $2.68 \pm 3.90 NL_{methane} \cdot gVS^{-1}$ and $2.68 \pm 3.90 NL_{methane} \cdot gVS^{-1}$ respectively. The least productive theses were 9-6-8 (B). While the others had an intermediate production (BC). Data marked with different capital letters are significantly different according to Tukey's test ($p < 0.05$).</i>	<i>157</i>

<i>Figure 4.6 The graph shows that the most productive theses were 7 and 4 (C), with a production of 629.88 Nm³/t[VS] and 610.87 Nm³/t[VS] respectively. The least productive theses were 9-6-8 (B). While the others had an intermediate production (BC). Data marked with different capital letters are significantly different according to Tukey's test (p < 0.05).</i>	157
<i>Figure 5.1 Graphical set-up of the BMP test with water displacement method for biomethane quantitation.</i>	171
<i>Figure 5.2 Reactors placed inside the climatic chamber at 37 °C.....</i>	171
<i>Figure 5.3 Production of NL_{methane}·gVS⁻¹ for the trial weeks. Data marked with different capital letters are significantly different by Tukey's test (p < 0.05).....</i>	176
<i>Figure 5.4 The graph shows that the most productive thesis was thesis 15 (C), with a production of 2942.91±3.15 Nm_{methane}. The least productive theses were theses 14,13 and 16 (B). Data marked with different capital letters are significantly different according to Tukey's test (p < 0.05).....</i>	176
<i>Figure 5.5 The graph shows that the productive thesis was thesis 15 with 2.94 ±3.15 NL_{methane}·gVS⁻¹. The least productive theses were thesis 20 and 18 (B). The data marked with different capital letters are significantly different according to Tukey's test (p < 0.05).....</i>	177
<i>Figure. 4.6 The graph shows that the productive thesis was thesis 15 with 582.92 ± 3.57 Nm³/t[VS]. The least productive theses were thesis 20 and 18 (B). The data marked with different capital letters are significantly different according to Tukey's test (p < 0.05).....</i>	178
<i>Figure 6.1 Graphical set-up of the BMP test with water displacement method for biomethane quantitation.</i>	188
<i>Figure 6.2 Reactors placed inside the climatic chamber at 37 °C.....</i>	188
<i>Figure 6.3 Production of NL_{methane}·gVS⁻¹ for the trial weeks. Data marked with different capital letters are significantly different by Tukey's test (p < 0.05).</i>	191

Figure 6.4 The graph shows that the most productive thesis was thesis 19 (C), with a production of $4835.79 \pm 4.902.65 \text{ NL}_{\text{methane}}$. The least productive theses were thesis 20 and thesis 18 (B). Data marked with different capital letters are significantly different according to Tukey's test ($p < 0.05$).192

Figure 6.5 The graph shows that the productive thesis was thesis 19 with $4.84 \pm 4.90 \text{ NL}_{\text{methane}} \cdot \text{gVS}^{-1}$. The least productive theses were thesis 20 and 18 (B). The data marked with different capital letters are significantly different according to Tukey's test ($p < 0.05$).193

Figure. 6.6 The graph shows that the productive thesis was thesis 19 with $641.57 \pm 1.29 \text{ Nm}^3/\text{t}[\text{VS}]$. The least productive theses were thesis 20 and 18 (B). The data marked with different capital letters are significantly different according to Tukey's test ($p < 0.05$)......193

Figure 7.1 Reactor set-up.....203

Figure 7.2 $\text{NL}_{\text{methane}}$ cumulative production.215

Figure 7.3 Daily production of $\text{NL}_{\text{methane}} \cdot \text{gVS}^{-1}$216

Figure 7.4 Weekly production of $\text{NL}_{\text{methane}} \cdot \text{gVS}^{-1}$ for the trial weeks. Data marked with different capital letters are significantly different by Tukey's test ($p < 05$).216

Figure 7.5 Feeding the reactors on substrate FM added weekly. Data marked with different capital letters are significantly different by Tukey's test ($p < 0.05$)......217

Figure 7.6 Feeding the reactors (grams of VS added daily) and during the trial weeks. Data marked with different capital letter are significantly different by Tukey's test ($p < 0.05$).217

Figure 7.7 Feeding the reactors (grams of VS added daily) and during the trial weeks. Data marked with different capital letter are significantly different by Tukey's test ($p < 0.05$).218

<i>Figure 7.8 Variation of OLR during trial weeks. Data marked with different capital letter are significantly different by Tukey's test ($p < 0.05$).....</i>	<i>219</i>
<i>Figure 7.9 Variation in percentage concentration of CH₄ during the trial weeks. Data marked with different capital letter are significantly different by Tukey's test ($p < 0.05$).....</i>	<i>219</i>
<i>Figure 7.10 Variation in percentage concentration of CO₂ during the trial weeks. Data marked with different capital letter are significantly different by Tukey's test ($p < 0.05$).....</i>	<i>219</i>
<i>Figure 7.11 Variation in percentage concentration of O₂ during the trial weeks. Data marked with different capital letter are significantly different by Tukey's test ($p < 0.05$).....</i>	<i>220</i>
<i>Figure 7.12 Variation in percentage concentration of H₂S during the trial weeks. Data marked with different capital letter are significantly different by Tukey's test ($p < 0.05$).....</i>	<i>220</i>
<i>Figure 7.13 Variation in percentage concentration of H⁺ during the trial weeks. Data marked with different capital letter are significantly different by Tukey's test ($p < 0.05$).....</i>	<i>221</i>

TABLE INDEX

<i>Table 2.1 Chemical-physical technical specifications for Natural Gas (Annex A, Decree 19-03-2007) (Corbellini, V. et al 2015).....</i>	<i>62</i>
<i>Table 2.2 Methane yield m³ per tonnes of volatile solids added (Braun et al. 2010).....</i>	<i>68</i>
<i>Table 2.3 By-products by agri-industrial supply chains and indicative estimates of annual quantities (Greco, C., 2011).....</i>	<i>70</i>
<i>Table 3.1 Samples of agrifood by-products and food waste used in the trials.....</i>	<i>97</i>
<i>Table 4.1 Samples of agrifood by-products and food waste used in the trials....</i>	<i>145</i>
<i>Table 4.2 Physical-chemical characterization of the substrates subjected to BMP tests. Values expressed as mean of replicates ± Dev. St.....</i>	<i>148</i>
<i>Table 4.3 Physical-chemical characterization of the substrates subjected to BMP tests. Values expressed as mean of replicates ± Dev. St.....</i>	<i>149</i>
<i>Table 4.4 Experimental set-up adopted for anaerobic digestion trials.....</i>	<i>150</i>
<i>Table 4.5 Physical-chemical characterization of the mixtures (substrate+inoculum) subjected to BMP tests. Values expressed as mean of replicates ± Dev. St.....</i>	<i>152</i>
<i>Table 4.6 Physical-chemical characterization of the mixtures (substrate+inoculum) subjected to BMP tests. Values expressed as mean of replicates ± Dev. St.....</i>	<i>153</i>
<i>Table 4.7 CH₄ yield expressed as NL and average methane percentages produced by each theses. Values expressed as mean of replicates ± Dev. St.....</i>	<i>154</i>
<i>Table 4.8 Results of the chemical-physical characterisation of the mixtures after undergoing anaerobic digestion. Values expressed as mean of replicates ± Dev. St.....</i>	<i>158</i>

<i>Table 4.9 Results of the chemical-physical characterisation of the mixtures after undergoing anaerobic digestion. Values expressed as mean of replicates \pm Dev. St.....</i>	159
<i>Table 4.10 Initial pH and final pH of the theses.....</i>	160
<i>Table 4.11 Percentage abatement of Volatile Solids. Results are expressed as percentage abatement of VS. Values expressed as mean of replicates \pm Dev. St.....</i>	161
<i>Table 4.12 Percentage abatement of COD. Results are expressed as percentage abatement of COD. Values expressed as mean of replicates \pm Dev. St.....</i>	162
<i>Table 5.1 Experimental set-up of substrate mixtures.....</i>	169
<i>Table 5.2 Physical-chemical characterization of substrates mixtures subjected to BMP tests. Values expressed as mean of replicates \pm Dev. St.....</i>	172
<i>Table 5.3 Experimental set-up and reactors content.....</i>	173
<i>Table 5.4 Physical-chemical characterization of the mixtures (substrate+inoculum) subjected to BMP tests. Values expressed as mean of replicates \pm Dev. St.....</i>	174
<i>Table 5.5 Cumulative methane yield and percentage of CH₄. Results are expressed as mean \pm DV.ST.....</i>	175
<i>Tables 5.6 Physical-chemical characterization of the mixtures (substrate+inoculum) after BMP tests. Values expressed as mean of replicates \pm Dev. St.....</i>	179
<i>Table 5.7 Initial pH and final pH of the theses.....</i>	179
<i>Table 5.8 Percentage abatement of Volatile Solids. Results are expressed as percentage abatement of VS.....</i>	180
<i>Table 5.9 Percentage abatement of COD. Results are expressed as percentage abatement of COD.....</i>	180
<i>Table 6.1 Experimental set-up and reactors content.....</i>	186

<i>Table 6.2 Physical-chemical characterization of the substrates subjected to BMP tests. Values expressed as mean of replicates \pm Dev. St.....</i>	189
<i>Table 6.3 Experimental set-up and reactors content.....</i>	189
<i>Table 6.4 Physical-chemical characterization of the mixtures (substrate+inoculum) subjected to BMP tests. Values expressed as mean of replicates \pm Dev. St.....</i>	190
<i>Table 6.5 Cumulative methane yield and percentage of CH₄. Results are expressed ad mean\pmDV.STE.....</i>	191
<i>Table 6.6 Physical-chemical characterization of the mixtures (substrate+inoculum) subjected to BMP tests. Values expressed as mean of replicates \pm Dev. St.....</i>	194
<i>Table 6.7 Initial pH and final pH of the theses.....</i>	194
<i>Table 6.8 Percentage abatement of Volatile Solids. Results are expressed as percentage abatement of VS.....</i>	195
<i>Table 6.9 Percentage abatement of COD. Results are expressed as percentage abatment of COD.....</i>	196
<i>Table 7.1 Chemical-physical characterisation of inoculum and mixture.....</i>	205
<i>Table 7.2 Reactor feed scheme g(feed)/day and its OLR (gVS/liter/day).....</i>	206
<i>Table 7.3 Reactor feed scheme gVS/day and gCOD/day.....</i>	208
<i>Table 7.4 Reactor N°1: Physico-chemical characterization of samples taken from the reactors during the digestion phase. Values expressed as mean of replicates \pm Dev. St.....</i>	211
<i>Table 7.5 Reactor N°1: Physico-chemical characterization of samples taken from the reactors during the digestion phase. Values expressed as mean of replicates \pm Dev. St.....</i>	212
<i>Table 7.6 Reactor N°1: Physico-chemical characterization of samples taken from the reactors during the digestion phase. Values expressed as mean of replicates \pm Dev. St.....</i>	213

Table 7.7 Reactor N°1: Physico-chemical characterization of samples taken from the reactors during the digestion phase. Values expressed as mean of replicates \pm Dev. St.....214

RIASSUNTO

I conflitti politico-militare in atto, le incertezze legate ai costi ed all'approvvigionamento dell'energia da fonti "tradizionali", le problematiche legate al cambiamento climatico impongono come obiettivo comune non più procrastinabile il perseguimento di una strategia comune, a livello mondiale, tesa al conseguimento di una energia pulita, sicura, economicamente competitiva e fruibile su vasta scala. Nel fronteggiare i vincoli della dipendenza energetica trova, pertanto, esplicitazione il rinnovato interesse al ricorso alle fonti energetiche alternative. Definire una strategia di sviluppo nel lungo periodo, basata sull'implementazione dei meccanismi d'incentivazione adottati e lo sviluppo di un sistema integrato ricerca-industria, in grado di accelerare l'introduzione e diffusione sul mercato di un portfolio di tecnologie energetiche low-carbon sempre più efficienti, è ciò a cui la politica internazionale dovrebbe perciò tendere; questo al fine di arginare il consumo sfrenato delle risorse naturali, garantendo al contempo la crescita dei sistemi economici nazionali ed uno sviluppo sostenibile durevole e finalizzato a fronteggiare anche il rischio dei cambiamenti climatici, senza gravare in modo sconsiderato sulle generazioni future.

In tale ottica, la Commissione europea ha adottato una serie di proposte per trasformare le politiche dell'UE in materia di clima, energia, trasporti e fiscalità in modo da ridurre le emissioni nette di gas a effetto serra di almeno il 55% entro il 2030 rispetto ai livelli del 1990. In questa nuova sfida che vede come protagonista le rinnovabili, un ruolo determinante giocherà in Italia il settore agro-forestale dove si registra una sempre maggiore attenzione per le filiere agro-energetiche, alle quali viene ad attribuirsi un ruolo nuovo, da affiancare a quello tradizionale quali, ad esempio, la produzione di biogas attraverso la digestione anaerobi di sottoprodotti di origine agro-alimentare. La digestione anaerobica è un processo biologico complesso per mezzo del quale dei microrganismi, operando in assenza di ossigeno e all'interno di reattori a temperatura costante, trasformano la sostanza organica, contenuta sia nei vegetali che nei sottoprodotti di origine animale, in biogas. Il biogas è una miscela gassosa, composta per il 50-80% da metano e per il resto da anidride carbonica, vapore acqueo, idrogeno e composti solforati. Normalmente, per questioni di convenienza economica, il biogas non viene sottoposto ad una fase di purificazione e di recupero del metano ma viene avviato alla combustione in cogeneratori, per l'ottenimento di energia elettrica e calore, generalmente dopo essere stato sottoposto a trattamenti di filtrazione, deumidificazione e desolforazione.

La presente tesi nasce con la finalità di sperimentare tale processo, utilizzando diverse tipologie di prodotti e sottoprodotti di origine agro-alimentari come substrati di partenza per la produzione ed il miglioramento della resa di produzione di biogas. Nello specifico, per la determinazione del potenziale metanigeno si sono effettuati una serie di test sia con metodo statico (o in batch) che dinamico utilizzando un reattore continuo a serbatoio agitato. I risultati ottenuti sono stati molto interessanti dal punto di vista sperimentale ed hanno evidenziato come la digestione anaerobica incentrata sull'agro-alimentare consenta di conseguire un notevole recupero energetico attraverso la produzione di metano.

ABSTRACT

The political-military conflicts currently underway, the uncertainties related to the cost and supply of energy from 'traditional' sources, and the problems related to climate change, impose the pursuit of a common strategy, now no longer procrastinable, aimed at achieving a clean, safe, economically competitive and widely usable energy on a global scale. In facing the constraints of energy dependence, the renewed interest in the use of alternative energy sources is thus expressed. Defining a long-term development strategy, based on the implementation of the incentive mechanisms adopted and the development of an integrated research-industry system, capable of accelerating the introduction and diffusion on the market of a portfolio of increasingly efficient low-carbon energy technologies, is what international policy should therefore strive for. This is in order to curb the unbridled consumption of natural resources, while guaranteeing the growth of national economic systems and lasting sustainable development, also aimed at coping with the risk of climate change, without imposing an inconsiderate burden on future generations. With this in mind, the European Commission has adopted a set of proposals to transform EU climate, energy, transport and taxation policies to reduce net greenhouse gas emissions by at least 55% by 2030 compared to 1990 levels. In this new challenge that sees renewables as the protagonist, a decisive role will be played in Italy by the agri-forestry sector, where there is increasing attention for agri-energy chains, to which a new role is being attributed, to be placed alongside the traditional one such as, for example, the production of biogas through the anaerobic digestion of by-products of agri-food origin. Anaerobic digestion is a complex biological process by means of which microorganisms, operating in the absence of oxygen and within reactors at a constant temperature, transform organic matter, contained in both plants and animal by-products, into biogas. Biogas is a gaseous mixture of 50-80% methane and the rest carbon dioxide, water vapour, hydrogen and sulphur compounds. Normally, for reasons of economic convenience, biogas does not undergo a purification and methane recovery phase but is sent for combustion in cogenerators to obtain electricity and heat, generally after undergoing filtration, dehumidification and desulphurisation treatments. This thesis was created with the aim of experimenting with this process, using different types of products, and by-products, of agri-food origin as starting substrates for the production and improvement of biogas production yield. Specifically, for the determination of the methanogenic potential, a series of tests were carried out with both a static (or batch) and

dynamic method using a continuous stirred tank reactor. The results obtained were very interesting from an experimental point of view, and showed how anaerobic digestion focused on agri-foodstuffs allows considerable energy recovery through methane production.

1. INTRODUCTION

The conflict in Ukraine has caused a significant rise in natural gas prices in the last two years, resulting in a complex energy issue that stems from a combination of political, economic, social, and environmental factors. This affects the security of supply and prices of crude oil and natural gas, particularly given the geopolitical instability in and around oil-producing countries. In addition, there is a growing demand for resources in developing countries like China and India, which has a detrimental impact on the environment. While the debate on global warming may persist, the precautionary principle necessitates the reduction of greenhouse gas and pollutant emissions (such as CH_4 , NO_x , SO_x , NH_3) as well as aromatic hydrocarbons, and a shift towards more sustainable lifestyles. This is crucial to prevent potential threats to the planet and future generations (Castelli et al., 2011). According to Pramanik et al. (2019), there is an energy and climate change issue. Additionally, globally, one-third of edible food is lost through the food supply chain. This fragment discusses the loss of food that occurs throughout the entire chain of production, supply, sale, and final consumption, as well as food waste resulting from poor supply management or incorrect eating habits. In this context, anaerobic digestion (AD) of biomasses such as agricultural by-products and food waste is a reliable method to reduce greenhouse gas emissions and utilise waste for clean energy production. Residues from food industries, livestock farms, and municipal waste still contain a significant amount of matter that can be converted into biogas and biomethane. This allows for less consumption of non-renewable sources and less production of polluting gases. Anaerobic digestion is a biological process where a bacterial consortium converts organic matter into biogas without oxygen. It is a complex process that requires careful management to ensure optimal performance. The biogas produced is composed mainly of methane (CH_4) (50-75%), carbon dioxide (CO_2) (25-50%), water vapour (H_2O), and traces of oxygen (O_2), nitrogen (N_2), and hydrogen sulphide (H_2S) (Thompson, Wang and Li., 2013). Currently, biogas is utilized for combined heat and power (CHP) production or purified and injected into natural gas networks for use as vehicle fuel, domestic purposes, or in fuel cells (Omar et al., 2008). Furthermore, AD produces a stabilised, odourless and nutrient-rich digestate as a by-product.

This digestate can be used as a fertiliser or soil conditioner for agronomic purposes due to its high content of plant macronutrients, such as nitrogen (N), phosphorus (P), potassium (K), and sulphur (S), as well as various micronutrients and organic matter (Karim et al 2005; Drogs, B., 2013). Accelerating research on renewable energy and introducing more efficient and environmentally friendly technologies in all energy-intensive sectors, including industrial processes, transport, heating, and air conditioning, is crucial. Additionally, economic and social development models need to be re-evaluated, and limited changes in lifestyles should be considered to make a significant contribution to energy conservation and pollution reduction. In this context, the anaerobic digestion process could significantly contribute to mitigating the effects of global warming and provide a viable energy alternative.

The paper is divided into six chapters as subsequently explained.

Chapter 1 an overview of the environmental sustainability and biogas regulatory framework and a description of the biological process and steps involved in anaerobic digestion.

Chapter 2 consists of an overview of the anaerobic digestion process. It is based on a systematic and critical review of the state of the art, technologies, systems, plants and parameters for starting and managing the entire process.

Chapter 3 deals with the materials and methods section. This chapter deals specifically with everything concerning the chemical-physical characterisation of the substrates and mixtures used in this work. In particular, reference is made to all the analysis methods used for the determination of pH, total solids (TS) and total volatile solids (TVS), ammonium, Total Kjeldahl Nitrogen (TKN), total volatile fatty acids (tVFA) and the determination of total polyphenols.

Chapter 4 reports a scientific article written by the author in which he focuses on the recovery of agri-food by-products and food waste for the production of bio-methane. In this work, 10 different substrates were subjected to anaerobic digestion, three replicates were considered for each thesis, making a total of 33 reactors considering also the replicates for the blank. The test took place under mesophilic conditions (37°C), with an approximate duration of 30 days and a TS content <10%. The biogas produced was evaluated daily.

Chapter 5, from the results obtained in the previous chapter, the most productive substrate in terms of biomethane produced was curd. Therefore, a study was conducted to evaluate the anaerobic co-digestion of four mixtures composed of a high percentage of curd (80%) and the remaining 20% of other substrates. Three replicates were considered for each thesis, for a total of 15 reactors including replicates for the blank. The test took place under mesophilic conditions (37°C), with an approximate duration of 30 days and a TS content <10%. The biogas produced was evaluated daily.

Chapter 6 in this section, a study was conducted on anaerobic co-digestion resulting in an evaluation of the biogas produced from three mixtures consisting of 70% of curd + 15% of bakery products and 15% of other substrates. Three replicates were considered for each thesis, for a total of 15 reactors including the blank replicates. The test took place under mesophilic conditions (37°C), with an approximate duration of 40 days and a TS content <10%. The biogas produced was evaluated daily.

Chapter 7 from the results obtained in Chapter 5, the mixture of 80% curd and 20% expired sausages was used to feed two continuous stirred tank reactors (CSTR) daily. These types of reactors make it possible to operate under conditions similar to what takes place inside industrial reactors and thus allows the application of the process to be better studied from a real-world point of view. Each reactor was fed with the same quantities of substrate on a daily basis. Each day, the biogas production trend was evaluated and parameters such as pH, temperature, organic load (OLR), etc. were assessed. While every three days, an aliquot sample was taken from the reactors to be chemically and physically characterised in order to assess the progress of the digestive process.

Chapter 8 reports the main conclusions of this thesis work and further developments of the study.

1.1 Importance of the environmental sustainability of biogas

International organisations have designed new energy scenarios that promote sustainable development of an energy market focused on environmental protection, security, and diversification of energy sources. Governments are currently developing and implementing strategies to reduce greenhouse gas emissions. This includes promoting the use of renewable and sustainable energy sources and improving the life cycle of products. The Kyoto Protocol was ratified by over 180 countries on 11 December 1997. It demonstrates the demand for alternative energy sources and innovative technologies to address the issue of balancing energy and the environment. The European Union is committed to the reduction of energy consumption, diversification of supplies, and protection of the environment through the climate-energy package. This package defines a framework for EU energy and climate policies for the period from 2020 to 2030. In November 2019, the European Parliament declared a state of climate emergency. The resolution has prompted the European Commission to ensure that all proposals align with the goal of limiting global warming to below 1.5°C by significantly reducing greenhouse gas emissions. Additionally, the European Commission presented the European Green Deal, which includes legally binding targets of 55% emission reductions by 2030 and achieving climate neutrality by 2050. When discussing renewable energy, we are referring to sources of energy such as photovoltaics, wind, wave, geothermal, biomass and anaerobic digestion that regenerate over time and do not compromise resources for future generations (Castelli et al., 2011). Of the many renewable energy options, biomass has the advantage of being able to produce energy for almost all energy markets, including electricity, heat and transport. The use of biomass for energy production is linked to the carbon dioxide cycle. When biomass is combusted, carbon dioxide is released into the atmosphere. However, this carbon dioxide is then absorbed through photosynthesis, which leads to the production of new biomass. This process creates a closed loop, making biomass a potentially sustainable energy source. The balance of CO₂ production, absorption and release is almost zero. Historically, biomass from wood and agricultural waste has been the primary source of energy for developing countries. However, it is now playing an increasingly important role for developed countries as they implement new agricultural practices

and explore new applications, such as using it to produce biofuels and methane through digestion processes. One important example is 'biofuels', which are liquid compounds such as biodiesel and ethanol, or gaseous compounds such as biomethane and biohydrogen, acquired through the processing of biomass. It is important to assess the ecological repercussions of the entire process of converting biomass into energy, including land and water consumption, supply logistics, economic efficiency of the supply chain, and environmental protection. Therefore, it is essential to manage land carefully to prevent rural areas from undergoing unsustainable transformations in the long term. Additionally, it is crucial to evaluate water usage, especially when cultivating energy crops such as herbaceous and annual starchy/sugar crops, annual herbaceous oil crops, annual ligno-cellulosic crops, and poly-annual herbaceous crops. To ensure a secure and continuous supply and avoid negative energy balances caused by transport, it is crucial to meticulously evaluate the supply of raw materials for energy plants. This can be achieved by organizing supply chains close to the production basins through spatial or farm planning of the plants. Energy-oriented farming practices can provide farmers with a sustainable source of income, even when regular crop prices are no longer profitable. This can encourage farmers to remain on the land, which helps to prevent potential environmental risks associated with land abandonment. When the supply chain involves biomass, it is important to address the following issues. The biogas supply chain is fuelled by locally sourced biomass and uses environmentally friendly technologies. The by-product, digestate, has chemical and physical characteristics similar to those of livestock manure and can be used in agronomic applications to add organic fertilisers to the soil if properly managed. One short-term development of biogas is its potential to be fed into natural gas networks after purification to biomethane and/or stored for urban or automotive use. This has considerable environmental benefits in terms of reducing organic carbon dioxide emissions (Vismara et al., 2011). Another application is the cogeneration of electricity through the use of endothermic engines or high-temperature steam cogeneration. The biogas sector in Northern European countries, particularly in Germany and Austria, has achieved significant levels of production by integrating with the agricultural sector. In Italy, the production and sale of electrical and thermal

energy have been recognized as agricultural activities, leading to considerable interest in biogas production as an entrepreneurial initiative in the sector. Estimates identify 8,500,000 tonnes of dry matter per year potentially destined for the agricultural biogas chain, with a potential production of about 2,700 MW (Vismara et al., 2011). The use of renewable sources, such as those produced by anaerobic digestion of agri-industrial and food waste, has the potential to promote the Italian, European, and global energy sectors, while also contributing to circular economy and environmental sustainability.

1.2 Italian and European regulatory framework for biogas and biomethane

Moving to the discussion of the legislative framework is important to address that the Italian national legislative framework on biogas is part of a particularly complex and EU regulatory context that has become increasingly complex over the last few decades, also due to the global political situation and increasingly urgent issues concerning climate change. Limited to the domestic panorama, it is necessary to mention first of all the *Ministerial Decree of 6 July 2012*, which illustrated the system of incentives for the production of energy from non-photovoltaic renewable electric sources, i.e. hydroelectric, geothermal, wind, biomass, and biogas, replacing the Green Certificates and the All-Inclusive Tariffs of *Ministerial Decree 18/12/2008*. This decree broadened the range of recipients of incentives by including, for the first time, also those plants that do not produce electricity from solar sources but exploit additional renewable resources. Access to these incentives is not, then, subject to any size requirements, as companies can be small, medium or large, provided, however, that they have been in operation since 1 January 2013 and are registered in the special register held by the GSE (Gestore dei Servizi Energetici) is a company set up in 1999, wholly owned by the Ministry of Economy and Finance, which deals with promoting and developing renewable energy sources and energy efficiency, (<https://www.gse.it/>, Articles 3-9). The reason why the domestic legislation intended to change the previous discipline lies in the fact that, given the European panorama, it was necessary to review the approach to the renewable energy system with a view to greater efficiency, cost-effectiveness and lower environmental impact (*Ministerial Decree of 6 July 2012*).

In relation to the above, Article 8 of the aforementioned ministerial decree deals with regulating access to the incentive mechanisms for biomass and biogas plants.

The provisions in question establish that “*the GSE shall identify, on the basis of what is stated in the authorisation for the construction and operation of the plant and declared by the producer in the manner set out in Appendix 3, which of the following types the plant is fuelled by*”:

- a) products of organic origin;
- b) by-products of biological origin listed in Table 1-A;
- c) waste for which the biodegradable fraction is determined flat-rate in accordance with Annex 2;
- d) waste not arising from separate collection other than letter c)”.

This identifies the incentive tariff, which depends on a series of factors better explained in the aforementioned article.

Subsequently, the *Ministerial Decree of 6/7/2012* was revised by the *Ministerial Decree of 23 June 2016* by which the possibility of access to the incentives was maintained only for plants admitted in a useful position in the Auction Procedures and in the Registers of the same Decree and for which the terms set forth for entry into operation have not expired (<https://www.gse.it/servizi-per-te/fonti-rinnovabili/fer-elettriche/incentivi-dm-06-07-2012>).

The access modalities illustrated by the aforementioned decree are three and vary depending on the size of the plant and the category of intervention.

The regulations on the subject of incentives were then enriched by *DL. no. 145/2018*, which extended the possibility of access to the incentives to “*biogas-fuelled electricity production plants, with an electrical power not exceeding 300 kW and forming part of the production cycle of an agricultural or livestock enterprise, carried out by agricultural entrepreneurs, also in consortium form, and at least 80 per cent of whose power is derived from waste and materials deriving from the agricultural enterprises that carry out the project, and the remaining 20 per cent from their second-harvest crops*” (Art. 1, paragraph 954).

This provision provides for two methods of access depending on the type of power of the plant:

1. Direct access for plants up to 100 Kw;
2. Access through registration in the registers for plants between 100 kW and 300 kW.

The incentive mechanism illustrated above was, subsequently, extended for the year 2022 by means of the amendment made to Article 40-ter of Decree-Law 162/2019 realised by the so-called. Decreto Mille Proroghe (Decree-Law No. 228/2021 conv. with Law No. 15/2022). However, a Ministerial Decree is expected to be adopted by 31 December 2023 to regulate incentives for biogas and biomethane produced or injected into the natural gas network in order to implement the so-called *RED II Directive (Article 11, Legislative Decree No. 199/2021)*.

In this regard, *Legislative Decree No. 199/2021* is part of the framework of the regulatory sources on the subject and acquires considerable relevance as its purpose is to ‘*accelerate the country's path of sustainable growth, laying down provisions on energy from renewable sources, consistent with the European objectives of decarbonization of the energy system to 2030 and complete decarbonization to 2050*’ (Art. 1). The legislative text sets as its objective to provide the necessary provisions for the implementation of the measures of the National Recovery and Resilience Plan (also known as PNNR) on energy from renewable sources in accordance with the National Integrated Energy and Climate Plan so as to ‘*[...] identify a set of coordinated measures and instruments, already geared towards updating the national targets to be set pursuant to Regulation (EU) no. 2021/1119, which provides for a binding target for the European Union to reduce greenhouse gas emissions by at least 55 per cent compared to 1990 levels by 2030*’ [Art. 1(3)]. Art. 11 of the aforementioned legislative decree establishes the disbursement of a special incentive for the production of biomethane, or its introduction into the natural gas network, making access to this mechanism conditional on the existence of specific requirements based on the quantities and types of materials in compliance with sustainability and emission reduction criteria ‘*[...] calculated on the entire mix of materials used by the anaerobic digestion plant, both for the portion intended for the production of electricity and for that intended for the production of biomethane, as governed by the decree of the Minister for the Environment and the Protection of Land and Sea of 14 November 2019, published in the Official Gazette no. 279 of 28 November 2019[...]*’ (art. 11, paragraph 3). More limited to the subject of biogas, two recent legislative decrees cannot but be mentioned: Decree-Law No. 17/2022 and Decree-Law No. 21/2022.

The first one, adopted with the aim of stemming the exponential increase in the cost of electricity and natural gas by also incentivising the development of renewable sources, in Article 12 bis regulates the possibility of using the by-products indicated in points 2 and 3 of table 1.A contained in Annex 1 of the *Decree of 23 June 2016 of the Ministry of Economic Development*.

2. *By-products from agricultural, livestock farming, green management and forestry activities.*

3. *By-products from food and agri-industrial activities:*

- *by-products of tomato processing*
- *by-products of olive processing*
- *by-products of grape processing*
- *by-products of fruit processing*
- *by-products of the processing of various vegetables*
- *by-products of sugar beet processing*
- *by-products of paddy rice processing*
- *by-products of cereal processing, baking industry, bakery products.*
- *by-products of fish processing;*
- *by-products of coffee roasting;*
- *by-products of beer processing;*
- *by-products of fruit and oilseed processing*

4. *By-products from industrial activities*

- *by-products of wood*
- *by-products of the organic matter recovery and recycling industry*

In biogas and biomethane plants provided they meet certain conditions:

- (a) *the substance or object arises from a production process, of which it forms an integral part, and the primary purpose of which is not the production of that substance or object;*
- (b) *it is certain that the substance or object will be used, in the same or a subsequent production or use process, by the producer or a third party;*

(c) the substance or article can be used directly without any further processing other than normal industrial practice;

(d) the further use is lawful, i.e. the substance or object fulfils, for the specific use, all relevant product, health and environmental protection requirements and will not lead to overall adverse environmental or human health impacts." (Art. 184 bis, Legislative Decree No. 152/2006).

A further requirement for the use of the above-mentioned by-products concerns the agronomic use of the digestate produced, which must comply with the provisions of Title IV of the Decree of the Minister of Agricultural Food and Forestry Policies of 25 February 2016.

Lastly, with regard to Decree-Law no. 21/2022, introduced as a response to the negative effects produced by the Russian-Ukrainian conflict, it is worth recalling Article 5 bis. This provision states that *"In order to contribute to energy independence from imported sources and to favour renewable production in agriculture, the full use of the installed technical capacity for the production of electricity from biogas (and biomass with a capacity of up to 1 MW) from plants already in operation at the date of entry into force of the law converting the present decree is allowed by means of additional production with respect to the nominal capacity of the plant, within the limits of the technical capacity of the plants and the technical capacity of the grid connection in addition to the input connection power already contracted, in compliance with the regulations in force on environmental impact assessment and integrated environmental authorisation".* Production must, however, comply with certain conditions indicated in the following paragraph:

- (a) [...] the production of electricity in addition to the nominal capacity of the plant is not incentivised;*
- (b) the further use of production capacity within the limit of 20% of the parameters in force shall not be subject to the acquisition of permits, authorisations or administrative acts of consent, however named;*
- (c) the further use of production capacity beyond the limits referred to in subparagraph b) may be made subject to modification of the existing grid connection contract".*

With that being said, moving to the discussion of anaerobic co-digestion it is important to highlight that the anaerobic co-digestion involves utilizing various categories of substrates in the anaerobic digestion process, which results in a significant boost in digester productivity and profitability. In Italy, most agri-livestock facilities utilise co-digestion methods involving livestock waste, dedicated crops, and/or by-products (Greco, 2011). Mixing various products enables compensation for seasonal waste fluctuations, prevents overloading or inadequate loading of the digester, and ensures process stability and consistency (Vismara R., Malpei F., 2008).

Some of the reasons for choosing co-digestion are:

- a) The ability to employ various substrates in the design stage allows for greater flexibility in managing biogas production.
- b) By-products and waste materials often come at a lower cost compared to the production and/or procurement of biomass from dedicated energy crops, with the potential for disposal remuneration in the case of genuine wastes.
- c) Farm size and/or sole reliance on livestock manure can limit the amount of power that can be installed.
- d) The incorporation of manure, dedicated crops, and by-products could potentially enhance the plant's feasibility or increase its installable power (Greco C., 2011).

1.3 Anaerobic digestion process

Furthermore, it is noted that anaerobic digestion (AD) is a multistage biological process carried out by a heterogeneous consortium of bacteria, in which complex organic matter is degraded, in the absence of oxygen, and converted into biogas, consisting mainly of methane CH_4 and carbon dioxide CO_2 (Xiao et al., 2019; Xu et al., 2018). The microorganisms involved in the process form a complex metabolic chain. The anaerobic digestion process is subdivided into four main phases: an initial phase of hydrolysis of the complex substrates accompanied by acidification with the formation of volatile fatty acids, ketones and alcohols; a subsequent acetogenic phase, in which acetic acid, formic acid, CO_2 and molecular hydrogen are formed from the fatty acids; and finally, methanization, i.e. the formation of methane from the organic acids produced in the previous phase (Cecchi et al., 2005) The anaerobic digestion process can be divided into four phases: hydrolysis, acidogenesis, acetogenesis and, the most important for the production of methane, methanogenesis, as reported in Figure 1.

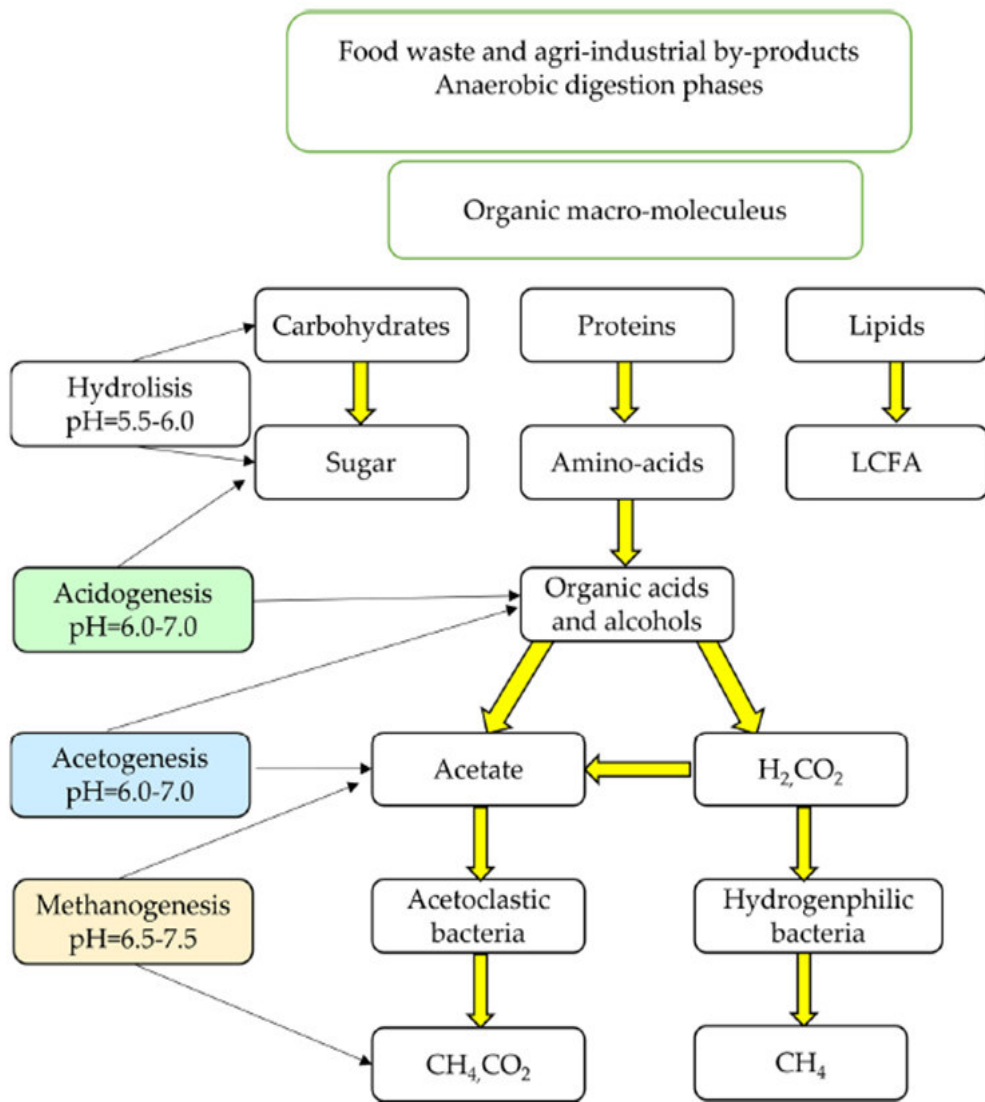

Figure 1. Flow chart of anaerobic digestion. Information collected from Pramanik et al., (2019)

All the phases that make up anaerobic digestion are discussed in more detail below. *Phase 1 → Hydrolysis*: In this first phase, through the intervention of various bacterial groups (hydrolytic bacteria), there is an initial degradation of complex particulate or soluble organic substrates such as proteins, fats and carbohydrates, with the formation of simple compounds such as amino acids, fatty acids and monosaccharides in soluble form (Vavilin et al., 1996), or produce extracellular enzymes capable of breaking down complex organic molecules into oligomers and monomers that are then made available for transport within the cells of fermenting acidogenic microorganisms. The hydrolytic process can be inhibited by the accumulation of amino acids and sugars (Sanders et al., 1999) due to interference in the production and activity of hydrolytic enzymes (Cecchi et al., 2005).

Phase 2 → Acidogenesis: In this phase, fermenting acidogenic bacteria generally carry out the oxidation of simple organic substrates to pyruvate, which is then converted into volatile fatty acids, alcohols and ketones that are the starting substrates for the subsequent acetogenic phase.

Phase 3 → Acetogenesis: here, the acetogenic bacteria will start from the substrates formed during the hydrolysis and acidogenesis phase (volatile acids, mainly propionate and butyrate, but also alcohols and ketones) and produce acetic acid, formic acid, carbon dioxide CO_2 and hydrogen H_2 . Angelidaki et al., (1998) reported that two different mechanisms must be considered depending on whether degradation takes place from long chain fatty acids (LCFA, long chain fatty acids) or short chain fatty acids (SCFA, short chain fatty acids, or VFA, volatile fatty acids). In general, long-chain fatty acids are defined as those with more than 5 carbon atoms. During acetic acid production, the presence of molecular hydrogen in the medium can lead to inhibition problems. If, however, H_2 is maintained at low concentrations, thanks to the activity of H_2 -oxidising methanogenic bacteria (hydrogenotrophs), the degradation of fatty acids to H_2 by acetogenic bacteria is made more probable, despite the fact that H_2 formation is energetically disadvantaged.

Phase 4 → Methanogenesis: In this phase, the actual production of methane CH_4 takes place and represents the conclusion of the anaerobic trophic chain. Methane production can essentially take place via two biosynthetic pathways. The first

pathway involves methanogenesis by hydrogenotrophic bacteria, which carry out anaerobic hydrogen oxidation, while the second biosynthetic pathway is the acetoclastic pathway, which involves anaerobic dismutation (a special oxidation-reduction reaction) of acetic acid with the formation of methane CH_4 and carbon dioxide CO_2 (Cecchi et al., 2005; Pramanik et al., 2019). With their activity, the two methanogenic bacterial strains perform two important functions within the anaerobic trophic chain: on the one hand, they degrade acetic and formic acid to CH_4 by removing the acids from the medium and thus preventing the inhibition of degradation phenomena of organic substrates by excess acidity, and on the other hand, they keep the H_2 concentration at low levels so that long-chain fatty acids and alcohols can be converted to acetate and H_2 . Indeed, if the hydrogenotrophic pathway is slowed down, an accumulation of H_2 is observed in the medium that inhibits methane production, while the acetoclastic pathway may undergo substrate inhibition phenomena in the presence of high concentrations of acetic acid (Cecchi et al., 2005).

2. AN OVERVIEW OF THE ANAEROBIC DIGESTION PROCESS

This chapter will discuss all the main technologies and parameters for starting and operating the biogas production sector.

2.1 Applicable types of plant and technologies

Anaerobic processes can be classified according to the thermal conditions of the process, the content of total solids content and the number of steps in the process.

Process thermal conditions can be divided into three broad categories, as follows:

- Psychrophilia → the process temperature range is $25 \pm 2^\circ\text{C}$.
- Mesophilia → the process temperature range is $35 \pm 2^\circ\text{C}$.
- Thermophilia → the process temperature range is $45 \pm 2^\circ\text{C}$.

With regard to the total solids content in digesters, there are different processes that can be applied on an industrial scale, distinguishing them on the basis of the concentrations of solids that characterise the treated organic waste, distinguishing the processes into:

- wet → with solids content of up to 10%
- semi-dry → solids between 15-20%
- dry → solids > 20%

In the explanation of anaerobic digestion processes, a differentiation can be made between one-stage and two-stage processes. In single-phase plants, all steps of the anaerobic digestion process take place in the same reactor, there is no pre-digestion resulting in longer hydraulic retention times. Whereas in a two-phase plant, unlike single-phase systems, the biomass first undergoes a preliminary hydrolysis process in a special 'batch' reactor and then the mass is transferred to the last digester where the methanization phase will take place.

The pre-digestion phase determines, in addition to an initial degree of mechanical and biological treatment (and thus higher yields), the optimisation of the subsequent fermentation process and a more regular feed rate (Weiland et al., 2009).

The operational sequence involves passing the biomass through a unit that acidifies the mass being digested and consists of one (or two, depending on the type of

substrate input) pre-digestion reactors, followed by an anaerobic digestion reactor and a final storage reactor. The digestate leaving the fermenter is then subjected to separation (with recirculation of the liquid fraction at the head of the plant); the solid digestate, depending on its intended use, may be subjected to possible drying to further lower its moisture content. The handling of the biomass within the plant is remotely controlled by means of a computerised pumping station.

In summary, the plant consists of the following operational steps:

- Pre-digestion (1 reactor), within the mixing reactor.
- Acidification unit (inside the pre-digestion reactor).
- Anaerobic digestion (1 2-stage compartmentalised fermenter).
- Final storage (1 reactor).
- Recirculation (1 tank).
- Separation of liquid fraction - solid digestate.
- Nitrogen stripping.
- Evaporation.
- Digestate drying.

The main advantage of two-stage biogas plants (also called “high-efficiency plants”) is that each process in the operational sequence can be optimised, as each stage is characterised by the presence of specific bacteria that can operate under optimal environmental conditions. The presence of a pre-digestion stage also allows the mechanical breakdown of substrates with a fibrous matrix (such as silage from herbaceous crops, straw, etc.) and thus optimal 'preparation' of the substrate for a more stable and regular anaerobic digestion stage (Braun et al., 2010).

The analogy is with the digestive system of cattle, whose stomach is divided into four 'environments', characterised by pH, temperature and specific bacteria, within which four digestion sequences take place (allowing the animal to digest the most fibrous foods). Hence the division of the plant into several successive phases, within each of which the bacteria can operate under optimal environmental conditions.

In single-phase plants, on the other hand, since the digestion process takes place in a single reactor, the different species of bacteria present have to adapt to the local environmental conditions, with the result that many of them operate outside their range, drastically reducing their productivity. In such plants, the pre-digestion and methanization processes inhibit each other because the environmental conditions required by each bacterium are very different; in the case of single-stage plants operating at low loads ($TS < 2 \text{ kg/m}^3 \cdot \text{day}$), these effects are not particularly noticeable, but as the load increases, the bacteria become increasingly sensitive and the processes become increasingly unstable and less efficient. On the other hand, the use of a two-stage technology with a hydrolysis reactor separated from the fermenter guarantees good process stability even at significantly higher loads ($TS > 7 \text{ kg/m}^3$) (Weiland, 2001). Methanogenic bacteria are very sensitive to sudden changes in pH, so the pH in the fermenter should be kept neutral (~ 7.5).

The hydrolysis process, on the other hand, requires an acidic environment with pH values close to 5 (Parawira et al., 2004). In two-stage biogas plants, the inhibitory factors for methanogenic bacteria are minimised because the biomass fed into the fermenter is hydrolysed and acidified beforehand. In contrast, if the substrate is fed directly into the digester, the shock to the microorganisms would be considerable and the risk of bacterial inhibition would be high. Compared to traditional single-phase systems, a dual-phase system therefore allows more efficient and regular biogas production with the same amount of organic substrate used (Weiland, P., 2001) (Greco, C., 2011).

2.2 Pre-digestion and acidification unit

During the initial phase of pre-digestion, particular enzymes break down organic substrates, including carbohydrates, fats and proteins, which then dissociate macromolecules into easily digestible simple molecules for methanogenic bacteria. The second acidification stage assimilates the simple molecules to form organic acids, alcohols, hydrogen, carbon dioxide, ammonium and hydrogen sulphide. Aforementioned elements will proceed to undergo additional decomposition by bacteria which produce acetic acid. As a result, they are transformed into substances which can be utilised by other bacteria that produce methane gas for the purpose of biogas production. It is important to note that, not only in the fermenter but also in the hydrolysis reactor, biogas is produced, albeit in smaller quantities.

Pre-digestion is a crucial stage in the entire digestion process. The successful culmination of this process necessitates the existence of three distinct microorganisms, namely acidifying bacteria, acetic acid-producing bacteria, and methanogenic bacteria. Each of these organisms requires ideal temperature and pH conditions. Due to significant differences in habitat requirements from anaerobic methanogenic bacteria, hydrolysis and fermentation take place in discrete units.

The pre-digestion reactor facilitates mixing between incoming solid matrix substrate and the liquid fraction (either slurry or recirculated from the separation phase). During this initial stage, organic matrix substrates are broken down and the biomass's behaviour is optimized for fermentation processes. As a result, biogas production yields are improved. Technical abbreviations will be explained when introduced. The process temperature ranges from 25°C to 65°C depending on environmental conditions, with residence time in the reactors between 1 and 3 days. The decomposed and pre-treated substrate from the initial acidification/hydrolysis stage is then delivered under pressure to the subsequent fermentation phase (Agro energia Naro S.R.L., 2013).

2.3 Continuous process

Continuous processing involves systems that are supplied with substrate on a continuous or semi-continuous basis. The hydraulic residence time (HRT) is determined by the average length of time that the substrate resides in the reactor. Figure 2.1 schematically represents one-stage and two-stage process. The microbial time is expressed as the residence time of solids (SRT). Processes may be one-stage or two-stage, permitting a relationship to be established between the residence time in the reactor and the changing kinetics of microbial strains in the two distinct stages of the digestion process (Cecchi et al., 2005).

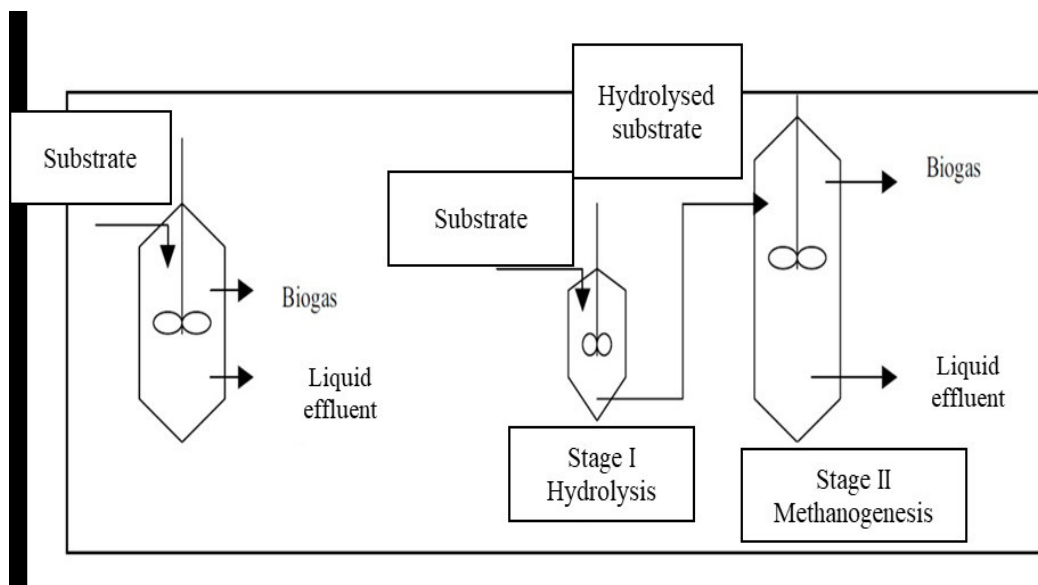

Figure 2.1 One-stage and two-stage AD process.

2.3.1 Fully mixed continuous reactor process without recirculation (CSTR)

In this type of reactor, the concentrations of substrate, products and biomass in the effluent are equivalent to the reactor content. Figure 2.2 schematically represents a complete stirred reactor without recirculation. This type of process, which is generally used for the stabilisation of sewage sludge or for wet or semi-dry processes of organic waste digestion, is characterised by the fact that the hydraulic retention time and the solids retention time are equal (Cecchi et al., 2005).

$$\mathbf{HRT = SRT = \frac{V}{Q};}$$

Where:

HRT= hydraulic retention time, [days];

SRT= average sludge residence time, [days];

Q= effluent flow rate, [m³/day];

V= reactor volume, [m³].

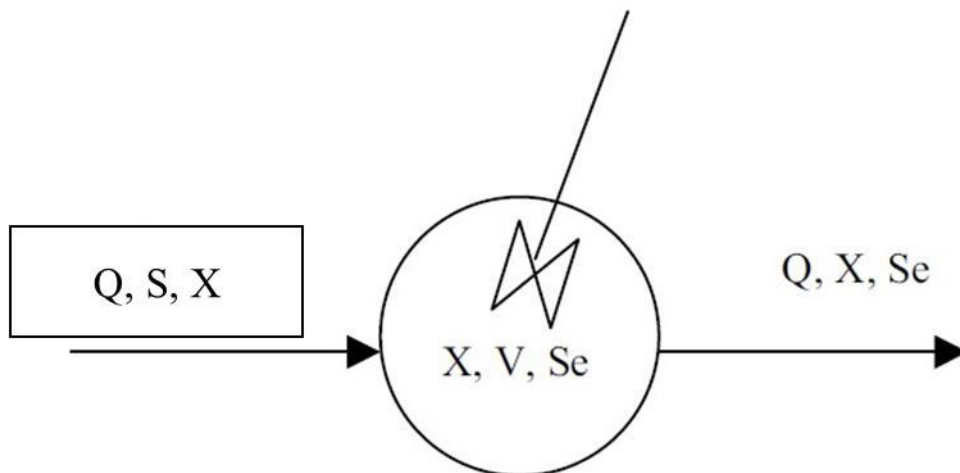

Figure 2.2 Full mixing reactor without recycling diagram.

2.3.2 Continuous reactor process with recirculation

Recirculation of the mass is generally incorporated, by process, to intensify the efficiency of stabilisation processes. The recirculation of part of the effluent allows part of the active biomass extracted with the effluent to be reintroduced into the digester, thus ensuring higher concentrations of the same within the reactor and a different solids residence time than hydraulically. This is generally achieved by separating the liquid fraction from the solid fraction and recirculating the latter within the reactor. Purging of excess sludge can be carried out from the recirculation flow or directly from the reactor (Cecchi et al., 2005).

2.3.3 Continuous process in a piston flow reactor

The process in a piston flow reactor, with continuous or semi-continuous flow, involves lateral feeding of the reactor with subsequent feeding along one of the reactor axes towards the outlet; mixing of the mass is ensured by a mixer orthogonal to the substrate feed axis. The residence time of each liquid element corresponds to the hydraulic residence time and only the concentration of the compounds along the feed axis will therefore be variable. The actual operation of such a configuration is only possible if biomass is allowed to be present in the influent stream, i.e. $X_0 \neq 0$. Otherwise, recirculation of the biomass will be necessary. It is this second solution which is generally used in real applications.

2.3.4 Continuous process with recirculation in a piston-flow reactor

This process scheme is used when substrates with a high dry matter content are used, as this overcomes the difficulties associated with proper mixing.

In this case, in analogy to the CSTR processes, solid/liquid separation of the effluent is foreseen: the solid part will be partially or totally recirculated within the reactor so that a good amount of inoculum is available and the concentration of active biomass within the reactor can be controlled. Recirculation of the effluent without any solid/liquid separation can be envisaged (Cecchi et al., 2005) Figure 2.3.

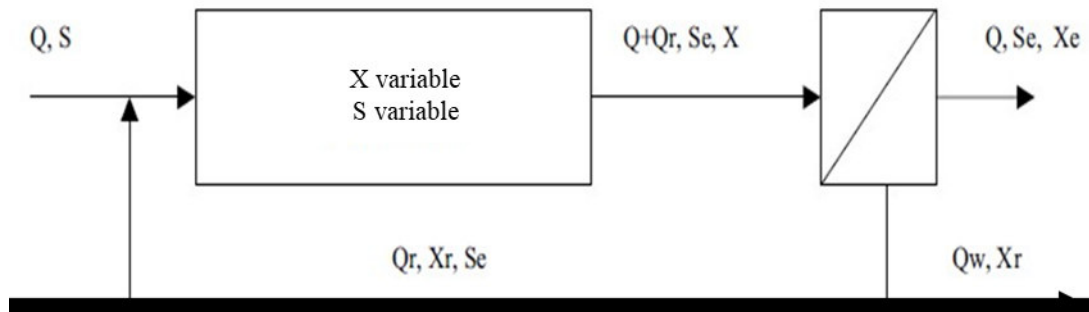

Figure 2.3 Continuous process with recirculation in a piston-flow reactor.

2.3.5 Continuous process with separate phase

As already reported, the bacterial consortium (hydrolytic, acidogenic and acetogenic) have completely different optimal growth conditions from the methanogenic bacteria. Therefore it is convenient to separate the digestion phases in separate reactors appears to be an ideal solution for increasing the yields of the two processes.

The overall process scheme provides for a first phase, hydrolysis → acidification, which takes place in smaller reactors, since retention times can be low, followed by a second phase, in larger reactors, in which methanogenesis takes place.

This allows the residence time in the reactor to be matched to the different kinetics of the microbial strains connected to the two different phases of the digestion process. Furthermore, this solution allows larger quantities of substrates to be processed, the two reactors can be of the fully mixed or piston flow type or a hybrid system (Cecchi et al., 2005).

2.4 Wet- digestion process

In wet processes, the starting waste is suitably treated and diluted to achieve a total solids content of less than 10% through dilution with water, or with recycled effluent water (Cecchi et al., 2005). In general, the process envisages, after the waste pre-treatment stage, aimed at removing inert matter and foreign bodies that could damage the reactor's mechanical parts, a homogenisation stage to obtain a mixture with the appropriate solids content (Figure 2.4).

Due to the physical characteristics of the treated waste, it is not possible to obtain a completely homogenous mixture and therefore, within the reactor, the digestion mass can be divided into three stages. The heavier fraction of inert and solid material tends to accumulate at the bottom of the reactor and can lead to damage in the mixing system, while less light materials (oils, fats, foams, etc.) accumulate at the top of the reactor. The intermediate density phase is where the actual biogas degradation and production reactions take place. In the plant operation, the plant is stopped for the removal of both the heavier layer, present at the bottom of the digester, and the lighter layer.

According to Cecchi et al., (2005) one of the problems that can be connected with wet anaerobic digestion is the hydraulic short-circuiting of the reactor: that is, the incoming material flow, which is not perfectly mixed with the material already present in the reactor, escapes with reduced retention times compared to the design. For this reason, some patents provide for a pasteurisation step of the effluent from the digestion reactor.

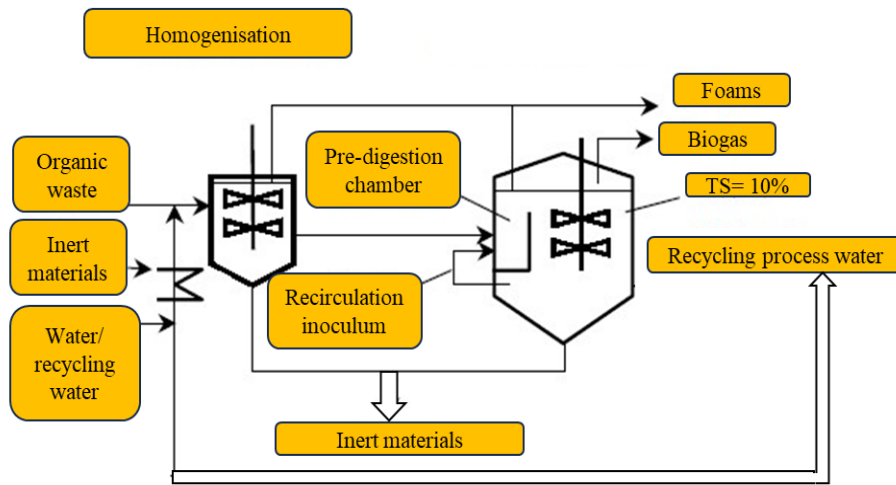

Figure 2.4 Typical single-stage wet process diagram.

The technological, biological and economic/environmental advantages of wet digestion processes are in order:

- Applicability of the process for co-digestion of liquid waste with high organic matter content.
- Dilution of toxic substances and influent substrate in the reactor.
- Reduced costs for pumping and mixing systems, and a large amount of water can be recovered and recycled in the digestion process.

While the disadvantages in order, are:

- Short hydraulic circulation, division of the mass into three phases, abrasion of the mechanical parts due to the presence of abrasive materials and finally, pre-treatment of the waste is required.
- High sensitivity to losses of biodegradable organic matter and variable organic loads.
- High investment costs due to waste pre-treatment processes and digester volumes. Moreover, even if it is possible to recycle process water, large volumes of water are still used (Cecchi et al., 2005).

2.5 Dry digestion process

In dry processes, the total solids content of the waste feeding the digester is generally in the range of 25-40% and therefore only particular wastes are used which have a high percentage of total solids (> 50%) and which need to be diluted with water in order to be conveniently treated (Alam et al., 2022).

Due to the physical characteristics of the waste (density, viscosity and %TS), the plant requires special pumping methods and this heavily influences the cost of setting up the plant. This plant can process highly concentrated material flows without the need for extensive pre-treatment. The only required pre-treatment is an initial screening process to remove materials larger than 40 mm. This is accomplished through the use of drum screens for mechanically separated organic waste and shredders for organic waste. As the dry process involves limited pre-treatment, there is no loss of biodegradable organic material as can occur during pre-treatment in the case of wet and semi-dry materials.

However, the high density and viscosity of the treated flows require the use of partially or fully plug-flow type reactors for dry treatment. From a mechanical standpoint, this simplifies the design of the reactors, but it can lead to difficulties in achieving proper mixing between the fresh organic waste and the fermenting biomass. Addressing this issue is crucial in preventing localized instances of organic overload and potential acidification that could hinder the methanogenic process (Cecchi et al., 2005).

The technological, biological and economic/environmental advantages of dry digestion processes are in order:

- No short hydraulic circuits, robustness and reliability of the mechanical moving parts.
- Low loss of volatile organic matter during pre-treatment, high OLR applicable to the fermenting mass and good resistance to peaks in the concentration of substrate or toxic substances.
- Minimal and inexpensive pre-treatment, reduced water consumption also due to low digester volatiles.

While the disadvantages in order, are:

- Can not be treated alone, all organic waste that has a low total solids content (< 20%)
- If toxic substances, inhibitors or high organic loads are present, they cannot be diluted.
- High investment costs due to pre-treatment.

2.6 Semi-dry digestion process

In this case, the digester operates with a total solids content in an intermediate range compared to wet and dry processes: in fact, it operates with waste with a solids content of 15-20%. From a plant engineering point of view, the solution adopted is that of a continuously stirred reactor (CSTR) that can operate in both mesophilic and thermophilic regimes.

The organic waste deriving from separate waste collection, used for this type of digester, has chemical-physical characteristics that are generally ideal for the direct application of the process, resorting only to simple pre-treatment to clean the waste with the elimination of ferrous and inert material, followed by shredding and mixing. On the other hand, when using organic waste from undifferentiated waste collection with a high solid content, a more drastic pre-treatment of cleaning and screening of the inert material is necessary, followed by dilution with recycled process water. In this case, i.e. where the plant treats undifferentiated waste, the waste needs to proceed through several steps that can significantly reduce the organic matter content.

In fact, according to Farnetti et al., (1999) about 15-25% of volatile organic matter may be lost during the pre-treatment steps. Also in this process, as in wet processes, the formation of three distinct phases can be observed within the reactor, although, in this case, the phenomenon is less pronounced. It will still be necessary to empty and clean the bottom of the reactor from time to time.

The mixing system is generally provided by mechanical mixers, which can also be assisted by the recirculation of the material in the digester sent to the boiler and then fed back into the digesters.

The technological, biological and economic/environmental advantages of semi-dry digestion processes are in order:

- Due to the low content of total solids, the plant will be able to use very simple pumping and mixing systems, and there is also the possibility of treating differentiated organic waste without any special pre-treatment.
- Dilution of substrate and toxic substances.
- Reduced expenses for pumping and mixing systems.

While the disadvantages in order, are:

- It can happen, that inside the digesters there can accumulate on the bottom of the inert material that will have to be removed, abrasion of the mechanical parts due to the presence of abrasive materials and finally, pre-treatment of the undifferentiated waste is necessary.
- High sensitivity to possible losses of biodegradable organic matter and variable organic loads and, loss of volatile organic matter in the case of pre-treatment of undifferentiated organic waste.
- High investment costs due to waste pre-treatment processes and digester volumes. In addition, the use and consequent production of high quantities of process water.

2.7 Two-stage digestion processes

This type of industrial approach, as already mentioned, involves the physical separation of the phases of anaerobic digestion. The first phase, the fermentative phase (hydrolysis and acidogenesis), takes place in one reactor, while the last two phases, the acetogenic and methanogenic phases, take place in a second reactor.

In the first phase, therefore, *hydrolysis* and *acidogenesis* of the mass will be observed according to first-order kinetics limited by the presence of cellulose, while the second phase is devoted to acetogenesis and methanogenesis. In this case, the limiting speed is that of methanogenic biomass growth (Palmowsky and Muller., 1999).

It has been observed, however, that two-stage digesters often do not allow such an increase in biogas production as to justify the higher investment and operating costs. Rather, the greatest advantage lies in the ability to process particular types of organic waste that are generally avoided in single-stage systems, such as particular agri-industrial or livestock residues with C/N ratios < 20 (Cecchi et al., 2005).

Two-stage processes can operate with or without biomass retention in the second stage. Depending on this design feature, different yields are achieved.

2.8 Different types of batch tests

The batch substrate analysis procedure can be applied to all organic solids or liquids that can be used as representative test substances. Fermentation tests of this type provide information on:

- Possible biogas yield and the anaerobic biological degradability of a substrate or substrate mixture.
- Qualitative assessment of the anaerobic degradation rate of the substrate under investigation.
- Qualitative assessment of the inhibitory effect of the test material in the test concentration range.

Fermentation tests do not provide information on:

- Process stability in reactors continuously fed with the test material or mixture of materials.
- The biogas yield under practical conditions, due to possible negative or positive synergistic effects.
- The mono-digestion of the substrate under process conditions, and the limits of the organic loading rate per unit volume.

The result of a fermentation test depends mainly on the microbiological activity of the seeding sludge used (which depends on environmental conditions, such as temperature and availability of the substrate, as well as the efficiency of the biologically active mass used), and the correct acquisition and evaluation of the quantities of biogas created. This means that if comparable results are to be obtained in fermentation tests, it is necessary to define not only the creation of a fermentation batch, but also the acquisition of gas production data and their qualitative evaluation with more precision.

The fermentation test equipment can comply with *DIN 38414 Part 8* or *DIN EN ISO 11734*.

Feed materials are incubated under mesophilic ($37 \pm 2^\circ\text{C}$) or thermophilic ($55 \pm 2^\circ\text{C}$) conditions. Climatic chambers can be used to control the temperature of fermentation batches. However, substrates that produce a floating layer or lees must be stirred thoroughly on a regular basis. In most cases, one thorough manual mixing during the test days is sufficient. The main reason for thorough mixing is to promote

degassing of the biogas that is formed and to avoid the formation of dry, inactive float layers.

When a substrate is particularly inhomogeneous (waste, organic waste and so on), it may be better to have larger fermentation volumes (10 L to 20 L), as this makes it easier to obtain representative samples.

If sample preparation and test objectives permit, smaller containers can also be used, as in the case of the Hohenheim biogas test, for example (Helffrich and Oechsner., 2003). The larger the sampling flasks - and thus also the amount of substrate used - the larger the sizing of the gas-sensing equipment must be.

This is especially true when fermenting energy-rich raw substrates these may include maize silage, fatty flots or food waste from which relatively high biogas production is expected. Since the internal pressure of the system has a negative influence not only on the gas tightness of the equipment, but also on the solubility of the biogas components in the fermentation medium, working with low pressures in the system is an advantage.

For this reason, equipment such as that specified in *DIN 38414-8* (Figure 2.5→2.10) should be preferred to *DIN EN ISO 11734* (Figure 7.), where significantly higher gas pressures can occur. The lowest system overpressures are achieved by not storing the biogas produced under pressure. This can be done by using plastic gas bags, employing a micro gasometer at low biogas production volumes between 1 L/h and 8 L/h similar to the Bergedorf biogas test (Scherer, P.A., 2002) and employing a drum gasometer at higher biogas production volumes.

The expected level of biogas production must be taken into account when selecting the gas meter. In the following describe six possible gas detection methods as examples (Figure 2.5 to Figure 2.10).

When detecting or measuring gas as specified in *DIN 38414-8* (Figure 2.5), the volume of gas produced is read when the levels of the confining liquid in the eudiometer tube and levelling bottle are equal.

In contrast to *DIN 38414-8*, with *DIN EN ISO 11734* the gas volume is measured indirectly using a pressure measuring instrument (Figure 2.6). The gas volume is calculated from the recorded gas pressure and the measured gas temperature.

The gas pressure must not exceed 100 hPa. Instead of using a pressure gauge, the gas can be collected in gas sampling tubes that are normally installed in a gas flask with confining liquid (Figure 2.7). The connection between the substrate flask and the gas sampling tube should, if possible, be a glass tube. Figure 9 shows a fermentation test bench for larger fermentation volumes. The fermentation vessel can, for example, have a volume of 10 L and the contents must be stirred thoroughly by means of an agitator. The biogas that is formed is collected in a plastic bag that is emptied periodically by means of a drum gas meter.

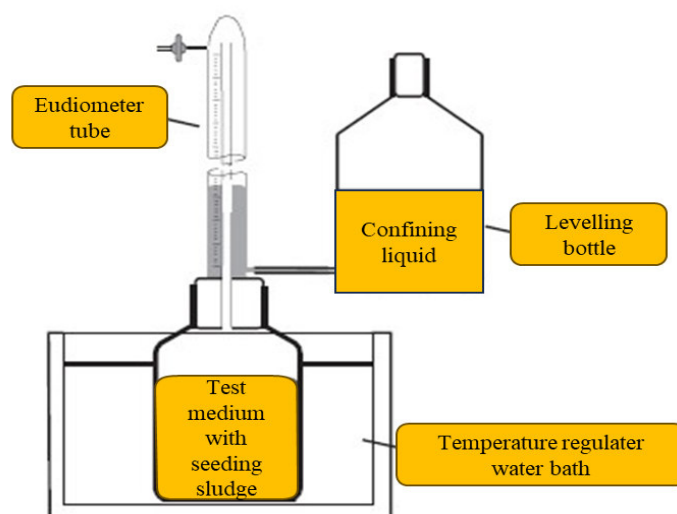

Figure 2.5 Test apparatus according to DIN 38414-8: Gas volume measurement with the eudiometer tube.

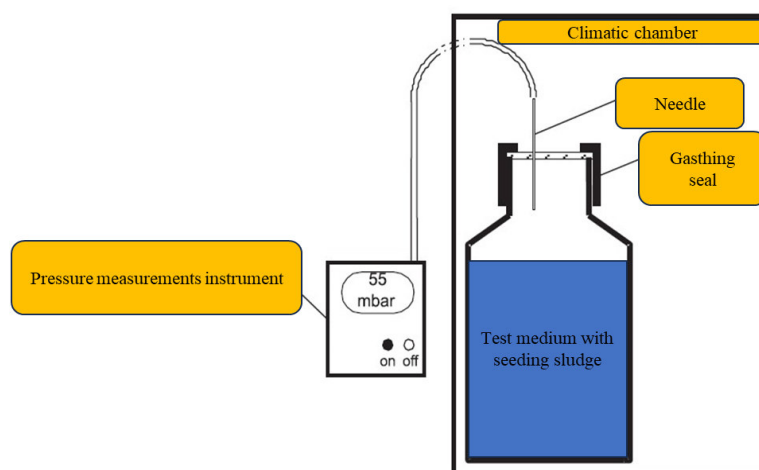

Figure 2.6 Test apparatus according to DIN EN ISO 11734: Gas volume measurement

Figure 2.6 is a schematic diagram of the so-called Hohenheim biogas fermentation test. This method does not require an additional gas sampling tube.

Between measurement periods, the biogas is collected in the syringe sampler, which also serves as a fermentation chamber. In this way, gas leakage through pipes connecting to a gas sampling tube is avoided. The syringe sampler is mechanically agitated to thoroughly mix the contents of the syringe. With these compact syringe samplers (which are part of a laboratory's standard equipment), several test substrates can be analysed at the same time and with different repetitions.

The gas quantity measurement systems shown in Figures 2.5, 2.6 and 2.8 can also be replaced by mechanical systems. In the case of small gas quantities, micro-gas-meter can be used (not exceeding 1 L/h up to 8 L/h) and drum gas-meters for larger volumes of gas production (1 L/h and above). These mechanical systems allow the formation of biogas to be measured automatically. In the Bergedorf fermentation test, the biogas formed is conveyed to a micro gas meter (Figure 2.7) whose central component is a tilting and rotatable hollow cube of defined and calibrated volume (1 ml or 8 ml). The electronic impulse resulting from the tilting movement is converted directly into millilitres via a display or generates gas formation diagrams using a software to acquire the measured values.

The gas composition can be analysed, for example, directly at the gas outlet of the device or via a gas bag, preferably fitted with a tube at the open end (Scherer, P.A, 2001; Scherer, P.A, 2002).

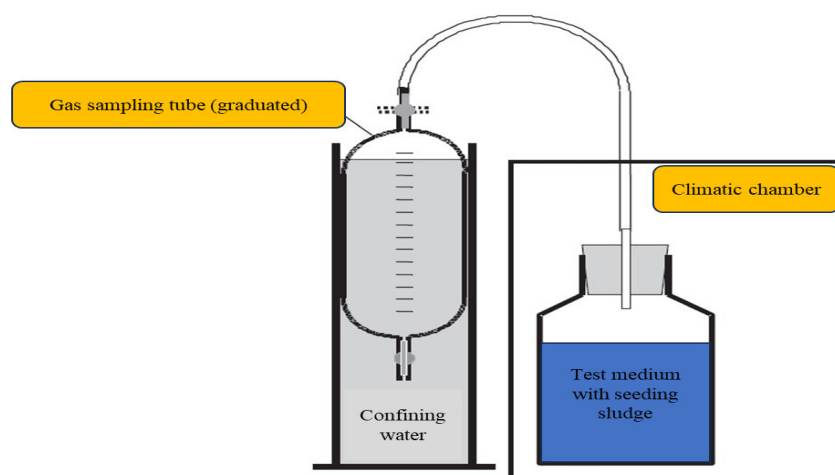

Figure 2.7 Test apparatus → Gas volume measurement with gas sampling tubes.

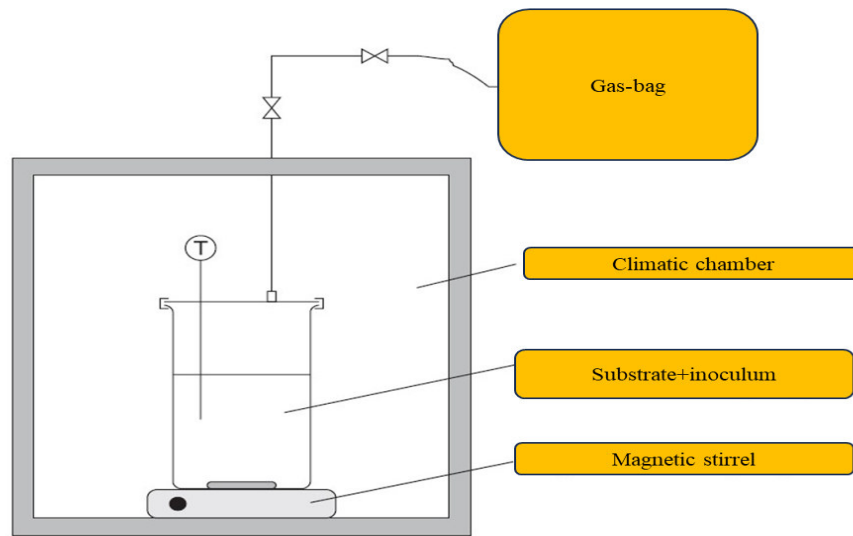

Figure 2.8 Gas volume measurement using gas- bags.

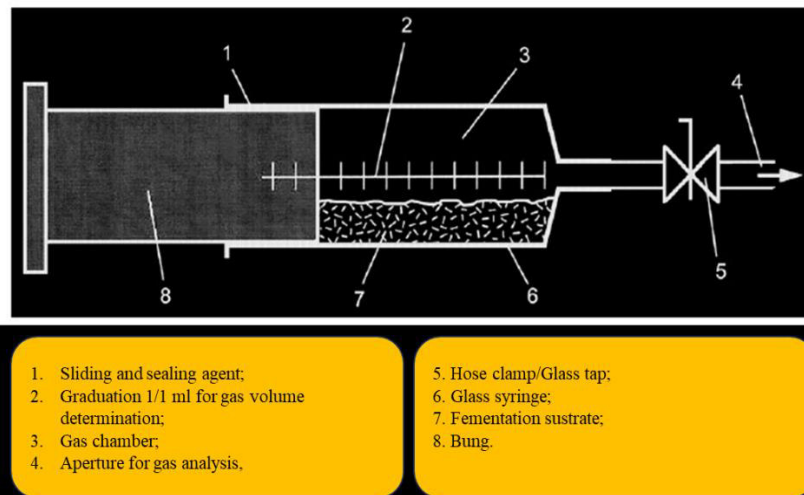

Figure 2.9 Schematic diagram of the Hohenheim fermentation test.

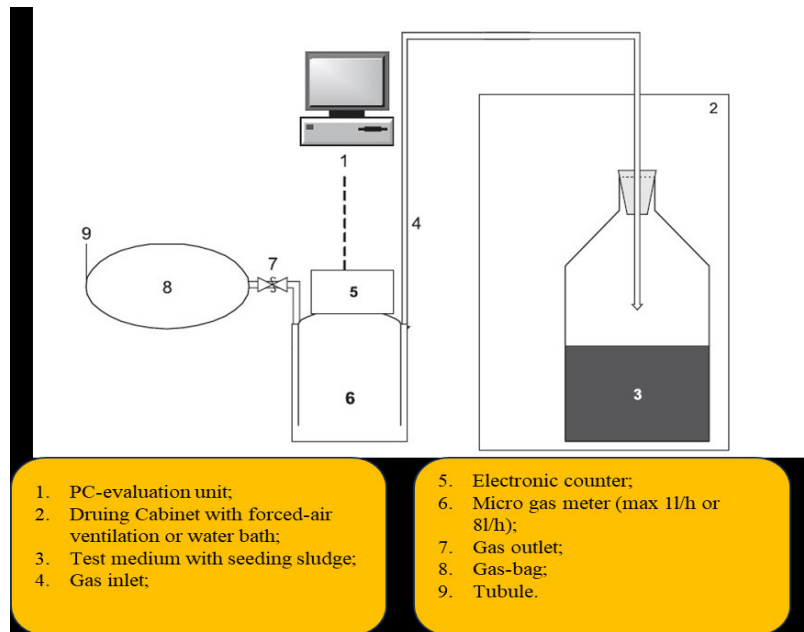

Figure 2.10 Gas volume measurement with the micro gas meter.

The advantage of gas meters, syringe samplers and plastic bags over other measurement systems is that they operate at low pressures. In all other systems, the water hammer (Figure 2.5 and 2.7) or increased pressure in the test batch (Figure 2.6) creates a back pressure that results in increased gas losses.

Test set-ups with gas volume meters, such as a micro gas meter or a drum gas meter, connected directly to the fermentation vessel, have the advantage that the measurement volume is not limited and the gas produced does not have to be vented. However, as the concentration of methane in the biogas is not constant throughout the duration of the test, with such a set-up to measure methane, the gas will either have to be passed continuously through the gas analysis or collected in a plastic bag, or the methane measurement will have to be repeated at sufficiently short intervals to obtain a representative figure for methane production (V. Verg, S. Substratcharakterisierung, and V. D., 2006).

2.9 Factors influencing the anaerobic digestion process

There are several factors, intrinsic and extrinsic, which can contribute positively or negatively to the anaerobic digestion process. They will be treated in detail below.

2.9.1 Temperature and effect on reaction kinetics

Temperature is among the most important factors in the anaerobic digestion process, as this can greatly influence the biogas production process. Anaerobic biological activity has been shown to occur over a wide temperature range: between -5 and +70°C (Cecchi et al., 2005). In these cases, it must be borne in mind that the microorganisms involved in the metabolic processes have different optimal temperatures. If the temperature is above or below their optimal range, the microorganisms involved may be inhibited or cause the death of the bacterial consortium.

The microorganisms involved in anaerobic digestion can be divided into three groups according to their temperature optimum. A distinction is made between psychrophilic, mesophilic and thermophilic microorganisms.

The optimum conditions for psychrophilic microorganisms are at temperatures below 25°C. At these temperatures, although it is not necessary to heat the substrates or digester, only low degradation performance and gas production can be achieved. As a rule, therefore, the economic operation of biogas plants is not feasible due to the long residence times of the sludge in the digesters. Most methanogenic bacteria have their optimum growth in the mesophilic temperature range between 35 and 42°C.

Biogas plants operating in the mesophilic range are the most common in practice because relatively high gas yields and good process stability are achieved in this temperature range (Wang et al., 2019). Whereas the other methanogenic bacteria, the thermophilic ones, have their optimum in the 50 to 60°C temperature range.

The high process temperature results in a higher decomposition rate and a lower viscosity of the phases. However, it must be considered that more energy may be required to heat the fermentation process. In this temperature range, the fermentation process is also more sensitive to disturbances or irregularities in the

substrate supply or digester operating regime, because fewer different species of methanogenic microorganisms are present under thermophilic conditions.

It has been shown that it is the sudden changes in temperature within the reactors that cause damage to the bacterial consortium, in fact a sudden drop of $\pm 2^{\circ}\text{C}$ can have a negative effect (Weiland et al., 2021). Whereas if the temperature changes slowly, methanogenic microorganisms are able to adapt to different temperature levels. It is therefore not so much the absolute temperature that is crucial for stable process management, but constancy at a certain temperature level.

The phenomenon of self-heating is often observed in practice and should be mentioned here. This effect occurs when substrates containing large quantities of carbohydrates are used in combination with the absence of liquid input materials and well-insulated containers. Self-heating is attributable to the production of heat by individual groups of microorganisms during the decomposition of carbohydrates. The consequence can be that, for example, in a system that originally operated under mesophilic conditions, the temperature rises to 43-48°C.

With intensive analytical back-up and corresponding process regulation, the temperature change can be managed with small reductions in gas production for short periods (Lindorfer et al., 2006). However, without the necessary interventions in the process (such as reducing the input quantities or lowering the maintenance temperature of the equipment) the microorganisms are unable to adapt to the temperature change and, in the worst case, gas production may stop completely (FNR, 2010).

Since the reaction rate is the governing phenomenon of the process, temperature becomes a parameter of fundamental importance. The typical temperature ranges encountered in anaerobic digestion reactors, as previously observed, are: mesophilic, thermophilic, and psychrophilic (more rarely applied).

When switching from one temperature regime to another, a real change in the composition of the bacterial community is observed. In fact, as illustrated in Figure 2.11, the development trends of the different bacterial populations are not monotonic, but have peaks at well-defined temperature intervals, different for each species. A change in temperature, within a certain range, and therefore for a given population, results in a change in reaction rates.

The expression for quantifying the effect of temperature variations on reaction kinetics is derived from the Arrhenius equation and can be expressed in the form:

$$VT = V_0 e^{\varphi(T-T_0)};$$

where:

VT = is the reaction speed at a certain temperature T ,

V_0 = is the reaction speed at the reference temperature T_0 ,

φ = experimental coefficient, which, in the usual temperature ranges of operating temperature ranges of digesters, can be assumed constant (Cecchi et al., 2005).

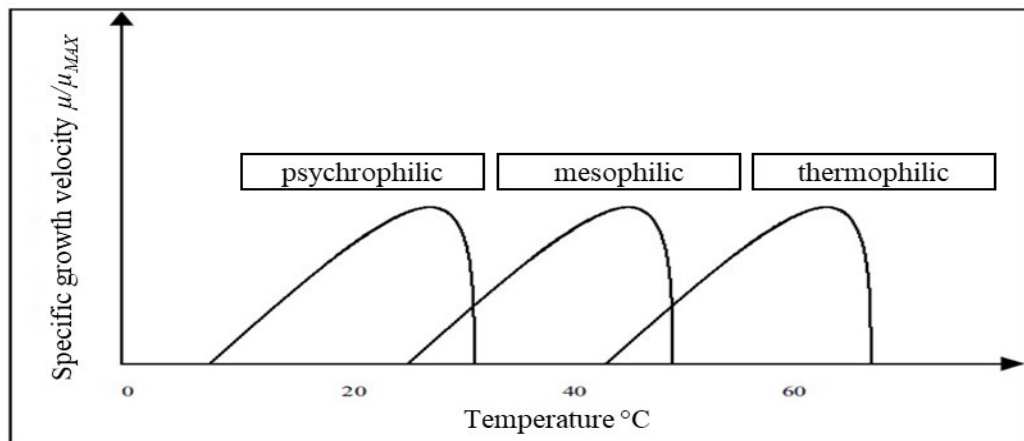

Figure 2.11 Influence of temperature on biological kinetics.

2.9.2 pH and alkalinity

The pH provides an indication of the stability of the reaction medium, as its variation is associated with both the buffering capacity of the system by the reaction medium and changes in the equilibrium between the species participating in the trophic chain of the microorganisms involved in the process (Cecchi et al., 2005). The microorganisms involved in the digestion steps require different pH values for optimal growth. For pH values between 6.5 and 7.5, the digestion process is generally considered stable. The optimal pH of hydrolytic and acidogenic bacteria is in the range of pH 5.2 to 6.3, for example (Weiland et al., 2001).

However, they are not totally dependent on this value; in fact, they are still able to convert substrates at a slightly higher pH value. The only consequence is that their microbiological activity is slightly reduced. In contrast, a pH value in the neutral range of 6.5 to 8 is absolutely essential for acidogenic acetic acid-forming bacteria and methanogenic archaea (Lebuhn et al., 2008).

Consequently, if the fermentation process takes place in a single digester, this pH range must be maintained. Regardless of whether the process is single-stage or multi-stage, the pH value is automatically established within the system by the alkaline and acid metabolic products formed in the course of anaerobic decomposition (Kaltschmitt et al., 2001). The presence of CO₂, ammonium and volatile fatty acids also play an important role in the anaerobic digestion process. Indeed, their presence can cause the pH of the digester to vary considerably, moving the system into a situation of high acidity. For example, if an excessive amount of organic matter is introduced into the digester, in a very short time, methanogenesis can be inhibited. In this case, the acidogenic bacterial consortium will take over from the methanogenic bacteria, producing significant quantities of acidic metabolic products, creating an acidic environment (FNR, 2010).

2.9.3 Alkalinity or buffering effect)

In addition to pH, of fundamental importance is the buffering effect. A buffering effect is defined as an aqueous solution capable of maintaining its pH virtually unchanged following the addition of moderate amounts of strong acids or bases, or with respect to dilution of the solution itself. The ability of a system to neutralise protons and is generally expressed in terms of calcium carbonate concentration (CaCO_3). This is determined, analytically, on the liquid phase in the reactor by titration with hydrochloric acid (Cecchi et al., 2005).

Under optimal and stable conditions, CaCO_3 amounts are between 3000 and 5000 mg eq. CaCO_3/l . According to Rosato, M. A. (2015), the ideal alkalinity would be 7000 mg CaCO_3 eq. per litre, as higher values lead to inhibition and dissolution of the active granules, while lower values lead to sharper pH excursions.

Furthermore, if the buffering capacity of the system is depleted or reduced, i.e. if too many organic acids have accumulated, the pH value is lowered.

This, in turn, increases the inhibitory effect of hydrogen sulphide, propionic acid and hydrogen sulphide, to the point where the digestive process in the digester comes to a halt in a short time. On the other hand, the pH value is also susceptible when ammonia is released into the medium as a result of the presence of organic nitrogen compounds; ammonia reacts with water to form ammonium.

The inhibiting effect of ammonia increases accordingly. The alkalinity of an anaerobic digester is essentially determined by the presence of a buffer system due to the coexistence of ammonia, originating from the degradation of proteins, and bicarbonate, resulting from the dissolution of carbon dioxide in the medium (FNR, 2010).

The interaction of carbon dioxide with the liquid phase and the consequent formation of the buffer system determined by the simultaneous presence of carbonic acid and ammonium with the formation of ammonium hydrogen carbonate (NH_4HCO_3). The presence of this salt dissolved in solution leads to a high alkalinity of the means resulting in process control even in the case of an accumulation of volatile fatty acids.

2.9.4 Total solids and volatile total solids

Water is a key parameter for initiating the AD process. Water content is important for the solubilization of nutrients and bacterial consortium.

Depending on the water content, anaerobic digestion can be of three different types: dry, semi-dry and wet. The moisture content in dry anaerobic digestion is around 10%, in semi-dry 15-20%, while in wet the content is higher at 20%.

In dry anaerobic digestion, the filling of the reactor volume, the energy and water consumption for handling the mass to be digested and the management/disposal of sludge and wastewater are drastically reduced (Wang et al., 2023).

Total solids (TS) and total volatile solids (TVS) can be determined according to *Method 1684* (Epa, U.S., and O.W. Office, 2001). The basis for most substrate analyses involves the determination of total solids (TS) and total volatile solids (TVS) content.

The TS content of a substrate is determined by drying the substrate at 105°C, thus removing water (and volatile organic compounds) from the fresh substrate matter. By incinerating the dry mass of the sample in a muffle furnace, the organic components are totally oxidised and the inert fraction remains.

Subtracting the remaining inert fraction from the initial dry mass from the initial dry mass, the total volatile solids (TVS) content of the substrate is obtained.

The TVS content represents an approximation of the of the organic fraction of the substrate (Cecchi et al., 2005; Weinrich et al., 2018).

2.9.5 Chemical Oxygen Demand (COD)

In accordance with *Method 5135*, the chemical oxygen demand (COD) is a parameter which indicates the total chemically oxidizable material in the sample and therefore a parameter which indicates the energy content (or organic pollution) of a feedstock. *It represents the quantity in mg of oxygen necessary to oxidize, in the presence of a strong oxidizing agent, the organic and inorganic substances present in a liter of sample in an acid environment.* The Chemical Oxygen Demand is expressed in mg/l^{-1} COD, defined as milligrams of O_2 consumed per liter of sample ($\text{mg/l}^{-1}\text{O}_2$). The field of application is defined by the technical specifications of the commercial tests used (de Zorzi et al., 2014).

Theoretically, 1 g COD (assuming that only organic carbon compounds are oxidised) is equivalent to a potential of 350 ml methane (V. Verg, S. Substratcharakterisierung 2006; Weinrich et al. 2018).

2.9.6 Theoretical relationship between COD and TVS

Theoretically, it is possible to find a correlation between COD and TVS. Since there is no standard defining in which units the results are to be expressed, it is easy to find the use of COD and TVS to express it in the literature.

From a formal point of view, it is indifferent to carry out anaerobic digestion tests by expressing the results in terms of COD or TVS, as both are ways of measuring the amount of carbon contained in a given biomass.

As a rule, COD is used as a unit of measurement of the organic matter contained in liquid substrates (sludge, sewage, vegetation water, etc.), while TVS are reference units of measurement for solid substrates.

To find the correlation between the two units of measurement of organic matter content, it is assumed that 50 per cent of the mass of TVS is carbon. Considering stoichiometry, it is known that 32 g of O₂ are required to oxidise 12 g of C.

From this, it can be derived that the COD of a given amount of TVS is equal to:

$$COD = 0.5 \cdot TVS \cdot \frac{32 \text{ g } O_2}{12 \text{ g } C} = 1.33 \cdot TVS; \text{ (Rosato, M. A., 2015)}$$

2.9.7 Concentration of volatile fatty acids

Volatile Fatty Acids are short-chain fatty acids (C-3, C-4, C-5), such as acetic acid, propionic acid, butyric acid and valeric acid or branched isomers of them, which are produced during the anaerobic digestion process. They are intermediate metabolites in AD process that are produced during the acidification step (acidogenesis) and are precursor of methane (Drosg, B. 2013).

The concentration of AGV is expressed as the concentration of acetic acid in the volume of material (mg/l), depends on the quantity and quality of the material loaded into the digester and the balance between acid-forming bacteria and bacteria methanogens (Adani, Schievano, and D'Imporzano., 2008). The ratio of acetic acid to propionic acid is an especially good indicator of process stability (Marchaim and Krause., 1993).

2.9.8 Volatile fatty acid/alkalinity ratio

The concentration of volatile fatty acids and alkalinity are the two parameters that show a more rapid change when the system tends to move away from stable conditions. Since fatty acid concentration tends to increase while alkalinity tends to decrease, a useful parameter to consider is the ratio between these two quantities. Ratio values around ± 0.3 indicate stable digester operation, while higher values may indicate the onset of stability problems (Cecchi et al., 2005).

2.9.9 Ammonium

Wastes with high concentrations of protein or nitrogen, such as pig manure, dairy products and chicken manure can form high levels of free ammonia, which is toxic to methanogenic microorganisms, resulting in low biogas production.

Ammonia nitrogen is less inhibitory in its ionic form (NH_4^+) compared to free ammonia (NH_3), but the distribution between these forms depends on the temperature and pH.

The system is tolerable to total ammonia nitrogen concentration range between 1500 and 7000 $\text{mgN}\cdot\text{l}^{-1}$ (Chen, Cheng, and Creamer., 2008).

When the ammonia content is high, methanogenesis is inhibited, it is usually the result of the accumulation of volatile fatty acids (VFA) to the point where the buffer capacity of the digester is not effective and the pH drops below 6 with a corresponding progressive loss of methane production (Abouelenien et al., 2014) and (Fricke et al., 2007). In the literature, very different inhibitory concentrations of ammonium nitrogen are given. According to (Chen et al., 2008) the maximum amount of ammonium should not exceed 14 g $\text{NH}_4^+\text{-N}\cdot\text{L}^{-1}$.

2.9.10 Total Kjeldahl Nitrogen

The nitrogen content of the feedstock can be approximated by determining the total Kjeldahl nitrogen (TKN). In this analysis, organic nitrogen is converted to ammonium nitrogen by boiling the feed samples in the presence of sulphuric acid and a catalyst. Then, similar to NH_4^+ -N analysis, a base is added and ammonia is distilled from the alkaline solution into an acidic solution (usually boric acid), where ammonia is absorbed quantitatively and measured.

Monitoring TKN content in the feedstock can be important because a change from nitrogen-rich feedstock will lead to ammonia accumulation in the digester which can cause ammonia inhibition (Drosg et al., 2020).

2.9.11 Carbon-nitrogen ratio

Nitrogen plays an important role in increasing the microbial population. The C/N ratio indicates the total ammonia nitrogen (TAN) released, the accumulation of volatile fatty acids (VFA) within the digester and the nutrient level of a substrate (Sun et al., 2016). In literature, the ratio of C/N to allow anaerobic digestion should be between 20:1 and 30:1, with an optimal fixed ratio of 25:1 to enable suitable growth of the bacterial consortium in an AD system (Khalid et al., 2011).

2.9.12 Nutrient supply

The microorganisms involved in anaerobic digestion have nutritional requirements that are species-specific in terms of both macronutrients and micronutrients.

The concentration and availability of these components influence the growth rate and biological activity of the bacterial consortium. There are specific minimum and maximum concentrations for each bacterial species that can cause an inhibition, or sometimes, interrupt their life cycle. In order to obtain as much bio-methane as possible from the substrates, it is necessary to ensure an optimal supply of macro- and micronutrients to the micro-organisms. From the point of view of macronutrients, it is crucial to correctly dose the proportions of carbohydrates, lipids and proteins contained in the feeding substrates (FNR, 2010).

As mentioned above, hydrolytic and acidogenic bacteria are able to break down macronutrients into molecules with an increasingly lower molecular weight. If large quantities of carbohydrates are present in the reactor, for example, the hydrolytic and fermentative bacteria will break these down into monomers, producing volatile fatty acids, mostly short-chain such as propionate and butyrate.

An excess of these volatile fatty acids may imply an increase in pH within the reactor, causing serious problems for the methanogenic bacterial consortium. From the literature, the toxicity limit for propionate appears to be around 3 g/L (Gourdon and Vermande., 1987). The degradation of propionate is also influenced by hydrogen which, in turn, can inhibit the microbial degradation of ethanol and, irreversibly, the growth of many anaerobic bacteria (Kaspar and Wuhrmann., 1978).

In terms of micronutrients, methanogenic bacteria have a basic need for cobalt (Co), nickel (Ni), molybdenum (Mo), selenium (Se), iron (Fe), chromium (Cr) and zinc (Zn) are needed as cofactors for essential reactions in their metabolism.

Magnesium (Mg), iron (Fe) and manganese (Mn) are other important micronutrients, necessary for electron transport and the function of certain enzymes (Panigrahi and Dubey., 2019) (FNR, 2010).

2.10 Inhibiting and degenerative factors in the anaerobic digestion process

The presence of some factors can inhibit or limit both the growth of the bacterial consortium, methanogens are microorganisms that are very sensitive to nutritional variations or to the presence of inhibiting elements. The parameters that can negatively affect the entire anaerobic digestion process are represented by the substrate itself and any inhibiting elements present in the substrates used; such as heavy metals, salts, ammonia nitrogen NH_4^+ , residues of pesticides and antibiotics, detergents and disinfectants, solvents, inhibitors from chemical treatments for food preservation, etc. The substrate itself can constitute an inhibition factor as its concentration can regulate and / or slow down the reaction rate of the subsequent stages having a negative effect on the bio-gas production.

For example, propionate is an important intermediate in anaerobic digesters, but it can be toxic if it exceeds 3 g/L (Cedex, Villeurbanne. 1987). More generally, it has been reported in the literature that high concentrations of volatile fatty acids (VFA) can have toxic effects by causing a strong acidification of the substrate.

Among the compounds that can inhibit the methanogenesis process are hydrogen sulphide, ammonia nitrogen, salinity, chloroform and other chlorinated products, disinfectants and antibiotics, as well as various metal species.

Methanogenic bacteria can tolerate concentrations of hydrogen sulphide up to 1000 mg/kg·TS even if the actual ability to produce methane is seriously compromised even at 200 mg/kg·TS. In general, the optimal conditions for the growth of methanogenic bacteria are obtained for sulphide concentrations between 8 and 22 mg/kg·TS (Visser, A., 1995). It has been observed that ammonia nitrogen concentrations between 1500 and 3000 mg/l are inhibitory at pH below 7.4 while concentrations above 3000 mg/l are toxic at any pH value (Adani et al., 2008).

The establishment of a high salinity reaction environment can negatively affect the anaerobic digestion process, blocking methanogenesis, identifying the tolerance limit from 250 to 500 mg/l. The inhibiting action of metal ions mainly concern the inhibition of the enzymes responsible for the biosynthesis of methane by the bacterial consortium. Studies performed on RU anaerobic digesters (Speece, R., 1983), indicate that there is a significant reduction of volatile fatty acids if the iron concentration is increased inside the digester (from 400 to 4000 mg/l).

Similar effects of reduction of methane yield can also be attributed to other metals such as zinc (toxicity limit = 160 mg/l), copper (toxicity limit = 170 mg/l), chromium and cadmium (toxicity limit = 180 mg/l) (Cecchi et al., 2005).

2.11 Management parameters of the continuous anaerobic digestion process

In addition to the parameters outlined above, in the case of a continuous process, i.e. an open system that is fed continuously or semi-continuously, the average residence time of the substrate in the reactor expressed by the hydraulic residence time (HRT) and that of the bacterial consortium.

Depending on the technology adopted, processes can be single-phase or two-phase. In single-phase processes, the biological steps of digestion, hydrolysis/acidogenesis/acetogenesis and methanogenesis take place in the same reactor and simultaneously. In two-phase processes, on the other hand, there are two separate reactors, placed in series with each other, each dedicated to a series of reactions: in the first reactor, hydrolysis/acidogenesis and acetogenesis take place, while in the second reactor, the methanogenic phase develops.

This makes it possible to associate the residence time in the reactor with the different kinetics of the microbial strains linked to the two different phases of the digestion process (Cecchi et al., 2005).

The reactor management parameters are:

Average time of hydraulic retention (HRT)

The average hydraulic residence time (HRT) is defined as the ratio of the volume of the reactor considered and the feed rate to the reactor:

$$HRT = \frac{V}{Q}$$

Where:

HRT: average time of hydraulic residence (days),

V: Volume of the reactor (m³),

Q: flow rate to the reactor (m³/day).

It represents the residence time of each fluid element inside a reactor (Drosg et al., 2020).

Average residence time of sludge (SRT)

The average residence time of the sludge inside the reactor is given by the ratio between the total mass of volatile solids present in the reactor and the flow rate of solids extracted from the reactor. If the amount of biomass produced by cell growth is equal to the amount extracted from the reactor, the concentration of active biomass inside remains constant over time and we will speak of steady state conditions.

You will have then:

$$SRT = \frac{V \cdot X}{W}$$

Where:

SRT: average residence time of the sludge, (days);

V: reactor volume, (m³);

X: concentration of volatile solids inside the reactor, (kgTVS/m³);

W: flow rate of volatile substance extracted from the reactor, (kgTVS/day).

Volumetric organic load (OLR)

The volumetric organic load of substrate applied to the reactor is defined as the amount of substrate entering the reactor referred to the volume unit of the reactor itself and to time.

Analytically:

$$OLR = \frac{Q \cdot S}{V}$$

Where:

OLR: volumetric organic load factor in terms of substrate referred to the reactor volume, (kg_{substrate}/m³ for day);

Q: influencing flow, [m³/day];

S: substrate concentration in the influencing flow rate, [kg/m³];

V: reactor volume, [m³].

This parameter is usually calculated on the basis of the useful volume of the reactor and can be referred to different units of measurement used to express the biomass concentration (TS, TVS, COD) (FNR 2016).

Organic load referred to biomass or volatile solids in the reactor (CF)

This is defined as the amount of substrate entering the reactor referred to the amount of volatile substance present in the reactor in the unit of time.

That is:

$$CF = \frac{Q \cdot S}{V \cdot X}$$

Where:

CF: organic load factor in terms of substrate (referred to biomass or volatile solids in the reactor), [kg_{substrate}/kgTVS_{day}];

Q: influencing flow, [m³/day];

S: substrate concentration in the influencing flow, [kgTVS/m³];

V: reactor volume, [m³];

X: concentration of volatile solids inside the reactor, [kgTVS/m³].

Specific Gas Production (SGP)

This parameter represents the quantity of biogas that is produced per quantity of volatile substance fed to the reactor; it is therefore expressed in terms of m³_{biogas}/kg_{feed substrate}. This parameter, widely used to define the yields of anaerobic digestion processes, is closely related to the biodegradability of the treated substrate rather than to the properties of the process adopted. From an analytical point of view it is expressed as the ratio:

$$SPG = \frac{Q_{biogas}}{Q \cdot S}$$

Where:

SGP, specific production of biogas, [m³ biogas / kg feed substrate];

Q_{biogas} flow rate of biogas produced, [m³/day];

Q, influencing flow, [m³/day];

S, substrate concentration in the influencing flow rate, [kg substrate/m³].

Biogas production speed (GPR)

It is defined as the flow of biogas produced with respect to the reactor volume and time:

$$GPR = \frac{Q_{biogas}}{V}$$

Where:

GPR, biogas production rate, [m^3_{biogas}/ m^3 reactor day];

Q_{biogas} , flow rate of biogas produced, [m^3/day];

V, reactor volume, [m^3].

Substrate removal efficiency

There are different ways of expressing the substrate removal efficiency during the anaerobic digestion process not only related to the different parameters used to express its concentration (total solid substance, volatile solid substance, COD or BOD). In general, the simplest relationship for the conversion of the substrate into biogas is expressed in percentage terms using the:

$$\eta \% = \frac{Q \cdot S - Q \cdot S_e}{Q \cdot S}$$

Where:

η : percentage of TVS removed, [%];

Q: influent and effluent flow, [m^3/day];

S: VS concentration in the influencing flow, [kg/m^3];

S_e : VS concentration in effluent flow calculated as the difference between the incoming mass and the biogas produced (easier flows quantification), [kg/m^3].

In the case of the removal of volatile substance, referring to the percentage of volatile substance that characterizes the influent and effluent of the reactor, the following expression is also suggested:

$$Removal_{VS\%} = \frac{VS_{in} - VS_{out}}{VS_{in} - (VS_{in} - VS_{out})} * 100$$

Where:

VS_{in} : as a percentage of the volatile fraction in the influent, %;

VS_{out} : percentage of the volatile fraction in the effluent, %; (Cecchi et al., 2005)

2.12 Applications of anaerobic digestion, biogas utilisation and biogas pre-treatment

Anaerobic digestion has three main areas of application within which it can be placed and from which the technologies for its management are derived. The first is the treatment of wastewater, particularly that with a high organic load, typically of industrial or agri-industrial origin. The second, with greater energy value, is the treatment of wastewater from zootechnical sources and the use of biomasses, whether they are produced ad hoc for energy purposes or come from production waste or separate waste collection. The third is the recovery of biogas from waste that still contains more or less significant amounts of organic matter and is sent to landfill. In recent years, the anaerobic digestion sector has experienced significant development due to the strong demand for renewable energy, the rising price of fossil fuels and the global geopolitical situation.

The most significant development has been the construction of new anaerobic digestion plants using biomass from the agri-food industry and separate waste collection. In the wastewater treatment sector, there has not been a large increase in the number of digesters, but rather a continuous drive to improve their efficiency in order to reduce reactor volumes and the time required to treat the same volume of wastewater, not least to reduce investment costs and process heat consumption.

In all areas of biogas production, there has been a general evolution in the ancillary process equipment and, in particular, an increase in the number of treatments to improve the quality of the gas: biogas is no longer simply fed into a boiler to produce heat, but is increasingly being used to feed a cogeneration unit that can also produce electricity. Conversely, this type of use requires a gas with superior quality characteristics to support the power requirements of the most advanced cogeneration units (ENEA, 2010).

2.13 Uses of biogas

The biogas obtained from the anaerobic digestion process can be used in three different ways:

- Direct combustion in a boiler, producing thermal energy only.
- Combustion in a co-generator, for the production of electrical and thermal energy. The heat produced is sometimes also exploited in absorption systems for the production of cooling energy, resulting in so-called tri-generation.
- Upgrading to biomethane for automotive use or for feeding into the gas grid (Mengon, S., 2017).

As mentioned above, the main element produced by anaerobic digestion is methane which, present in percentages varying from 50 to 65% with peaks of up to 80%, determines the energy characteristics of biogas. The calorific value of methane, i.e. the amount of heat that is generated by the complete combustion of the gas, is in fact a linear function of the methane content in the mixture.

To obtain the value of the calorific value of methane gas, one cubic metre is taken as a sample and burned at a temperature of 0°C and at atmospheric pressure (Acea energia, 2023). Thus, considering a hypothetical optimal biogas with 100 % methane content, corresponding to a lower heating value of 9.2 kWh/Nm³, the LHV value (lower calorific value) for biogas produced under real conditions ranges from 4.6 to 6.0 kWh/Nm³ (Feiz et al., 2020).

The utilisation of biogas produced by anaerobic digestion of organic substrates can lead to some operational difficulties related to plant maintenance as a result of a few main causes, including:

- Corrosiveness of biogas due to the formation of hydrogen sulphide (H₂S) during the digestion process. Corrosion can occur both at the level of the parts in direct contact with the biogas (pipes, meters, gasometer, reactor surface, burners, boilers, CHP units) and at the level of the entire plant, as gas leaks from the effluent and other parts make the environment particularly difficult for inadequately protected metal components. Wherever possible, it is therefore preferable to use materials that have little

or no hydrogen sulphide attack, or to install special filters to remove hydrogen sulphide.

- Formation of condensation in biogas pipes occurs due to the saturation of biogas with water at higher process temperatures than the ambient temperature. As a preventative measure, gas pipes must always be positioned at a slight negative or positive slope, avoiding the formation of pockets. Moreover, a purge tap must be provided at all low points of the pipes, ideally, with a condensate storage tank preceding it.

Lastly, the removal of condensate from pipes and condensate separators should occur on a daily basis.

- Fouling formation was frequently observed in the pipes, predominantly localized in the outlet pipes of the digested sewage, weirs, suction area of the centrifugal pumps and heat exchangers.

Struvite precipitates (magnesium ammonium phosphate) were found to be the most common cause of fouling formation as they are highly insoluble under the reactor pH conditions.

- Exposure to freezing temperatures can damage external pumps, gas pipelines, and liquid supply and waste discharge lines, as well as recirculation systems. It is recommended that all pipelines not continuously filled are constructed with sufficient slope to allow for drainage when pumps are turned off. In all pipelines that remain full, a continuous circulation must be ensured (or intermittence must be interrupted by brief periods of rest); if continuous circulation cannot be guaranteed, tracing of the pipelines or pumps with anti-freeze heating cables must be provided.

In case of system shutdown during the winter season, emptying of the parts exposed to freezing must be provided in any case. It is evident that it is essential to incorporate a plant section dedicated to cleaning the produced gas.

The most frequent pretreatments that need to be considered when using biogas are:

- Filtration using filters of different types is a crucial process to eliminate suspended solids, including organic substances, fats, and foams, before suctioning recirculation compressors or auxiliary compressors for the boiler and gas engines.
- Dehumidification is necessary due to the high degree of humidity in biogas leaving the digester at a temperature of at least 35 ± 2 °C, leading to the condensation of water vapour.

Consequently, condensation collection and purging sumps are installed to ensure proper functioning along the pipes. To prevent condensation in the combustion chamber, it is imperative to significantly reduce moisture.

- Removal of carbon dioxide is possible through the use of different technologies including: physical adsorption, with water or organic solvents; chemical adsorption, with amine or saline solutions (K_2CO_3); pressure Swing Adsorption (PSA); membrane separation; cryogenic upgrading. Through this process, the inert gases which mainly consist of CO_2 are separated while CH_4 is concentrated. This is done by adjusting the calorific value and relative density to meet the necessary requirements of the Wobbe index (Arera, 2005).
- Desulphurization is required to break down sulphur compounds. This process can occur through chemical filters containing iron oxides, which cause the precipitation and subsequent extraction of the compounds. Alternatively, scrubbing towers, in which gas is washed against the tide through a flow of water and ferric oxide, or biological desulphurization, through the introduction of a percentage of air directly into the digester (approximately 5-10% of the gas), can be used to facilitate the triggering of a biological sulphur precipitation reaction by specific bacterial strains (CTI, 2007).

After refinement, the biogas is purified of all non-conforming elements and concentrated to between 83 and 99%. Subsequently, it can be stored in vehicles as *compressed natural gas (CNG) or liquefied biogas (LBG)* (Bailón Allegue and Hinge, 2012). CNG is the most prevalent form, where methane is compressed at high pressure (200-250 bar), and low temperatures, odourised and fed into the national grid (tab. 2.1). The Technical Specification *UNI-ISO/TS 11537:2019* in Italy offers technical guidance for evaluating gas quality and introducing biomethane derived from purified gas produced via renewable sources into transport and distribution networks. This ensures that safety and continuity of service is maintained in compliance with current legislation.

Technical term abbreviations are explained upon first use, and sentences are structured logically with causal connections between statements. Language is kept objective, precise, and value-neutral with formal register, and conventional format is maintained using consistent citation and footnote styles (UNI-ISO/TS 11537:2019).

The technical specification describes in particular:

- the minimum chemical and energy characteristics of biomethane for feed-in to the grid,
- the methods of analysis and sampling,
- the measurement of quality parameters and odorization,
- the data connection between quality control systems and measurement of biomethane, odorization and feeding into the grid.

Table 2.1 Chemical-physical technical specifications for Natural Gas (Annex A, Decree 19-03-2007) (Corbellini, V. et al. 2015).

Compounds	Unit	Range of acceptability
Methane	(*)	-
Ethane	(*)	-
Propane	(*)	-
Iso-butane	(*)	-
Normal-butane	(*)	-
Iso-pentane	(*)	-
Hexanes and higher	(*)	-
Nitrogen	(*)	-
Oxygen	% mol	≤ 0.6
Carbon dioxide	% mol	≤ 3
Trace compounds		
Hydrogen sulphide	mg/Sm ³	≤ 6.6
Sulphur from mercaptans	mg/Sm ³	≤ 15.5
Sulphur from mercaptans	mg/Sm ³	≤ 150
Physical properties		
Higher Heating Value	MJ/Sm ³	34.95-45.28
Wobbe index	MJ/Sm ³	47.31
Relative density	-	0.5548-0.8
Water dew point	°C	≤ -5 (to 7000 relative kPa)

(*) for these components, the acceptability values are inherently limited by the range of acceptability of the Wobbe Index.

One of the most important factors to evaluate is the Wobbe Index (I_w) expressed in MJ/m^3 , which is given by the formula:

$$I_w = \frac{HHV}{\sqrt{\rho}}$$

where:

ρ : is the relative density of the gas with respect to the density of air under standard conditions;

HHV: is the higher heating value expressed in MJ/m^3 .

Relative density is a dimensionless parameter defined as the ratio between the density of the density of the gas to the density of the air.

The Higher Heating Value, in MJ/Sm^3 , is calculated using the chemical composition outlined in the most recent version of *UNI-ISO 6976:2017*, taking into account the ideal values specified in the same standard.

The determination of both the Upper Calorific Value and the Wobbe Index assumes the following standard enthalpy reference.

- pressure: 101,325 kPa;
- temperature: 288,15 K (= 15 °C).

In 2019, the UNI-ISO published the new edition of the technical specification *UNI-ISO/TS 11537* ‘Feeding biomethane into natural gas transmission and distribution networks’; this document contains the requirements for the limit concentrations for the so-called additional components of biomethane.

The limiting concentrations of the additional components stipulated in the *UNI-ISO/TS 11537-2019* technical report are:

- total silicon content, Si: $0.3 \div 152 \text{ mg}/\text{Sm}^3$;
- carbon monoxide content, CO: $\leq 0.1\% \text{ mol}$;
- ammonia content, NH₃: $\leq 10 \text{ mg}/\text{Sm}^3$;
- amine content: $\leq 10 \text{ mg}/\text{Sm}^3$;
- hydrogen content, H₂: $\leq 1.0\% \text{ vol}$;
- fluorine content, F: $< 3 \text{ mg}/\text{Sm}^3$;
- chlorine content, Cl: $< 1 \text{ mg}/\text{Sm}^3$ (ARERA, 2020).

To date, the technologies for converting biogas into electrical and thermal energy are:

- Internal combustion engines: Otto cycle internal combustion engines are the most frequently employed technology in biogas plants. These engines have been modified to burn the biogas typically utilised in most plants built to date by adapting the carburetion and ignition systems.
- External combustion engines: As an alternative to the classic use in internal combustion engines, there are Stirling cycle-based engines on the market, capable of utilising biogas (CTI, 2007). The operating principle of Stirling engines is based on a periodic thermodynamic cycle involving the compression and expansion of the working fluid in a closed volume, thus transforming heat into mechanical energy. The working fluids often used for the process are pressurised gases such as nitrogen, helium or even hydrogen (Schneider et al., 2020).
- Direct Combustion in Boilers: direct combustion is undoubtedly the easiest approach to utilize biogas. Burners are employed for heating spaces, feeding drying facilities, or for producing hot water.

2.14 Organic substrates and, possible pre-treatment, which can be used in the ad process.

Anaerobic digestion for biogas production is a process that erects the utilisation of a very wide range of biomasses. Theoretically, any substrate of an organic nature can be exploited for this purpose, but with limitations. These limitations are of a microbiological (process), technological, regulatory and economic nature, which require careful evaluation and in-depth knowledge of the substrate's chemical and physical qualities. Another of the problems associated with using biomass for anaerobic digestion is that its seasonal variability and its energy density per unit mass are the two most problematic aspects of biomass compared to other renewable energy sources.

The substrates used to feed the digesters can be grouped into the following main categories according to their sector of origin:

- 1) Livestock manure (manure, slurry, poultry manure, etc.);
- 2) Dedicated energy crops (maize, sorghum, tricale, etc.);
- 3) Agri-industrial by-products and animal and vegetable waste;
- 4) Sewage sludge;
- 5) Organic Fraction of Municipal Solid Waste.

The various categories of raw materials used as substrates in the anaerobic digestion process will be described below.

2.14.1 Livestock waste

Animal waste consists of the waste products of a livestock farm. In the literature, a distinction is made between livestock waste as such (physiological waste from the digestive process) faeces and urine, or livestock waste in the global sense (i.e. a mixture of manure, possibly mixed with water and solid material used as bedding (straw, sand, sawdust, etc.)).

Livestock manure has a very variable composition, depending on the animal that produces it, its diet, the farming conditions, etc.

Mainly they can be divided into:

- Cattle manure: solid faeces produced by cattle; it is the most common type of waste, in terms of weight and is characterised by being palatable with a total solid content of approximately 18-28%.
- Cattle slurry: a waste product from cattle urine, a non-palpable manure with a total solids content of about 5-9%.
- Pig slurry: is the effluent from pig urine, it is a non-palpable manure with a total solids content of between 1% and 7% depending on the type of farming.
- Poultry: is the main poultry manure, it is composed of a mixture of manure and urine, it is a palatable manure with a total solids content of about 18-20%. It has a high nitrogen content and, this causes high amounts of ammonia to be released during the digestion process. The use of large quantities of manure during the digestion process can cause ammonia quantities to rise and cause the methanogenic process to stop.
- Sheep manure: is the solid effluent produced by sheep, it is a palatable manure with a total solids content of about 30-40%.
- Horse manure: solid effluent produced by horses, it is a palatable manure with an amount of total solids of about 30-40%.

Figure 2.12: shows the classification of livestock manure according to the percentage of total solids (%TS).



Figure 2.12 Classification of livestock manure according to the percentage of total solids.

2.14.2 Agricultural biomass and energy crops

Agricultural biomass is the biodegradable fraction of products, by-products and residues of biological origin from agriculture. This type of biomass can come from crop residues unsuitable for animal feed, from damaged or excessively wet silage, from agricultural by-products consisting of residues from agricultural activities (fodder, poor quality fruit and vegetables, straw, distillation residues, mowing and pruning residues, etc.) or from dedicated energy crops. The total solids content of silage and agricultural by-products varies greatly depending on the type of energy crop: typical values for maize silage are between 32 and 34%, while they are slightly lower for other crops. Many plant species and plant residues have been tested for their methanogenic potential. Some crops used for digestion are listed in Table 2.2 (Braun, Weiland, and Wellinger 2010).

Table 2.2 Methane yield m³ per tonnes of volatile solids added (Braun et al., 2010).

Maize (whole crop)	205 - 450	Barley	353 - 658
Wheat (grain)	284 - 426	Triticale	337 - 555
Oats (grain)	250 - 295	Sorghum	295 - 372
Rye (grain)	283 - 492	Peas	390
Grass	298 - 467	Alfalfa	340 - 500
Clover grass	290 - 390	Sudan grass	213 - 303
Red clover	300 - 350	Reed Canary Grass	340 - 430
Clover	345 - 350	Ryegrass	390 - 410
Hemp	355 - 409	Nettle	120 - 420
Flax	212	Miscanthus	179 - 218
Sunflower	154 - 400	Rhubarb	320 - 490
Oilseed rape	240 - 340	Turnip	314
Jerusalem artichoke	300 - 370	Kale	240 - 334
Potatoes	276 - 400	Chaff	270 - 316
Sugar beet	236 - 381	Straw	242 - 324
Fodder beet	420 - 500	Leaves	417 - 453

2.14.3 Agri-industrial by-products and food waste

Agri-industrial wastes and by-products consist of all wastes, of organic matrix, generated as waste by the production cycles of agri-food industries. According to *Directive 2018/851/EU* of the 'circular economy' package: *'food waste is any substance or product intended for human consumption which has become waste because the person who has it has discarded it, intends to discard it or is obliged to discard it'*. These types of waste can originate from different types of agri-food industries such as: dairy industries, confectionery industries, canning industries, etc. In addition, market waste, catering waste and distillery waste are also excellent substrates for use in anaerobic digestion. Their energy yield varies greatly depending on their chemical and physical composition. However, this type of substrate must undergo pre-treatment to remove all possible contaminants (plastic, cardboard, glass or wood packaging) and in some cases, the waste must be treated to eliminate health and hygiene risks. When using these types of waste to feed the digester, their availability throughout the year (seasonality) and their ease of transport and handling must be taken into account. Table 2.3 shows the potentially usable and available by-products, classified according to their sector of origin (Castelli, S., Negri. M., 2011). By way of example, while by-products and processing waste of animal origin are virtually available throughout the year, this does not apply to by-products of plant origin. In fact, the latter type of waste is often linked to the seasonality of the plant species from which they derive. Some by-products, such as tomato peels or pomace can be easily stored and used throughout the year, which is quite different when it comes to fruit and vegetable waste (e.g. fresh produce or IV range vegetables). With regard to animal by-products (SOA), plants that process this type of waste must be authorised in accordance with *Reg. (EU) 1069/2009* laying down health rules concerning animal by-products and derived products not intended for human consumption and repealing *Reg. (EU) n. 1774/2002* (Greco, C., 2011).

Waste must meet the requirements of *Reg. (EU) 208/2006*. This possibility is limited to materials of:

- Category 2, after sanitisation treatment (T=133 °C, P= 3bar, t= 20s);
- Category 3, after pasteurisation treatment (T= 70°C, t= 1h).

However, this is waste that requires careful and considered management due to its high hygienic and sanitary risk.

Table 2.3 By-products by agri-industrial supply chains and indicative estimates of annual quantities (Greco, C., 2011).

Groups of by-products and waste	Agri-industrial sector	
Cheese whey, butter milk, livestock manure	Animal husbandry, dairy industry	
Fats, stomach and intestinal contents, blood, flotation sludge, canning waste	Meat processing and canned animals	
Vegetables and fruits offcuts, processing waste	Fruits and vegetables for fresh consumption and fruit juice	
Tomato peeling, potato peeling, citrus pulp	Vegetable preserves	
Rice husks, waste flour, bakery waste	Milling confectionery	
Grape marc, lees, stalks	Wine industry	
Molasses, bagasse, garland, sugar beet residues	Sugar industry	
Pomace, wet pomace, olive mills waste water	Oil industry	
Oil cake, pomace, glycerine, vegetable gums	Oilseeds, olive industry, biofuels	
Stubble, straw, clipping and prunings green maintenance	Agriculture and urban greening	
Quantities of by-products and waste	t/year	
Tomato skins	200.000	Balsari, 2009
Barley straw	996.500	
Rice straw	1.112.000	
Grape straw	181.100	
Corn drying waste	141.910	
Cheese whey	6.513.340	
Grape marc	1.054.240	
Slaughterhouse waste: available/viable for AD	1.7 milioni/411.762	Colonna et al., 2009
Crop residues (T/year)	8.500.000	CRPA, 2009

Many authors have investigated anaerobic digestion and co-digestion of agri-industrial by-products and food waste. Some of the most interesting works on this subject are listed below. For example, Li et al., (2015) tested the digestion process of vinegar residue using a continuous stirred tank reactor (CSTR). They tested the influence of organic loading rate (OLR) and effluent recirculation on the AD performance of the vinegar residue. Five OLRs were selected, 1.0, 1.5, 2.0, 2.5 and 3.0 gTVS l⁻¹ d⁻¹. The highest volumetric methane productivity of 581.88 ml CH₄ l⁻¹ d⁻¹ was achieved with an OLR of 2.5 gTVS l⁻¹ d⁻¹. Palatsi et al., (2011) carried out anaerobic digestion of fresh waste from the slaughter of pigs and cattle, evaluating different ratios between lipids and proteins using a batch test. The resultant methane potentials were high (270–300 l CH₄/kg COD⁻¹). Kafle et al., (2012) used waste from the seafood processing industry for biogas production. The evaluated mixtures were concocted by blending fish remnants with bread remains and brewery barley waste. Their potential to produce methane was assessed. The biogas and methane yield for fish waste silages after 96 days was calculated to be 671–763 ml/gTVS and 441–482 ml/gTVS, respectively. Meng et al., (2015) tested the effect of different concentrations of FO waste (5, 20, 30, 40 and 50 g/l) on the biomethane produced using batches containing mixtures of floating oil (FO) extracted from food (FW). FO and FO + FW were mono-digested and co-digested. The results showed that FO and FO + FW could be effectively anaerobically converted to biomethane using appropriate loads. For the single digestion of FO, the biomethane yield, TS and TVS reduction were 607.7–846.9 ml/g, 69.7–89% and 84.5–92.8% respectively. However, anaerobic digestion appeared to be unstable when the FO concentration was 50 g/l. Maximum FO loads of 40 g/l and 30 g/l were therefore suggested for efficient mono-digestions and co-digestions of FO and FO + FW. Zhang et al., (2014) evaluated the anaerobic co-digestion of food waste and bovine manure in order to define the key parameters that determine the best yield in terms of biogas and methane. The results of both batch and semi-continuous tests indicated that total methane production improved in co-digestion, with an optimal ratio of food waste (FM) to cattle manure (CM) of 2. With this ratio, a total production of methane in the batch corresponding to 388 mL/gTVS was obtained. Meanwhile, in the semi-continuous mode, the total production of methane in co-digestion was 317

mL/gTVS. Zhang et al., (2012) examined and tested the feasibility of improving biogas production and the stability of the anaerobic single-digestion process for food waste (containing the main meat, rice and vegetables) through co-digestion using fresh leachate from a urban solid waste (USW) incineration plant with the aim of identifying the key factors that regulate the performance and stability of anaerobic digestion. For this purpose, a series of semi-continuous experiments were carried out. During their tests, anaerobic co-digestion with fresh leachate showed much better performance and stability in terms of exhibiting high yields of CH₄ (375.9–506.3 ml/gTVSadded), no VFA inhibition and a stable pH (7.2–7.8). Yong et al., (2015) tested the BMP using food waste and straw in mesophilic conditions. Laboratory-scale blends were used with different ratios of FW to straw with an OLR of 5 gTVS/l. The methane production yield (MPY) reached 0.392 m³/kgTVS with an optimal mixing ratio of FW to straw of 5:1. Li et al., (2017) evaluated methane yield based on the assessment of 12 types of food waste, considering a substrate/inoculum ratio of 1:2 on a volatile base. Experimental data and model simulation results suggested that higher methane production (530–548 mL/gTVS) and volatile solid removal efficiencies (65.0–67.8%) can be obtained when the percentage of lipids is between 77.8 and 78.2% and that of proteins is between 54.7 and 58.2%. Meanwhile, a shorter digestion retention time could occur if the carbohydrate content is higher than 47.6%, the protein content is less than 24.1% and the lipid content is less than 28.3%. Park et al., (2012) used the biomass residue of algae in co-digestion with fat, oil and fat waste (FOG) rich in lipids to evaluate the effect on methane yield. The co-digestion of the algae biomass residue and FOG produced 0.54 L CH₄/gTVS/day with a volumetric productivity of the reactor of 1.62 L CH₄/day. Lipids contributed significantly to methane production, accounting for 68–83% of the total methane potential. Xu and Li, (2012) investigated the feasibility of solid-state anaerobic digestion (SS-AD) of expired dog food and stewed maize for biogas production. The substrate was tested at three different inoculum-to-substrate ratios (S/I), 2, 4 and 6, using sludge digester effluent as an inoculum. The most favourable methane yield obtained was 304.4 L/kgTVS_{feed}, which was achieved using the substrate consisting of 50% corn stover and 50% dog food. Kazimierowicz et al., (2021) conducted a study on a laboratory scale using

food waste products under mesophilic (37 °C) and thermophilic (55 °C) conditions. The maximum biogas yield was obtained in the mesophilic digestion of the substrate mixture containing 50% meat, 40% dairy and 10% fruit and vegetables. It was 740.4 ± 19.9 mL CH₄/gTVS biogas with $68.6 \pm 1.8\%$ methane. The effects of the substrate/inoculum ratio (S/I), the alkalinity sources (sodium bicarbonate and oyster shells) and the mixing ratio of inoculum to food waste were studied by Lee et al., (2019). The digester with an S/I =1, using a mixture of crushed oyster shells and sodium bicarbonate as a buffer, had the highest methane yield (183 mL CH₄/gTVS). The same authors reported that the addition of waste-activated sludge to food and catering waste mitigated acidification (pH 6.86 ± 0.12) during the start-up period and improved digester stability. Blends with FW/YW/WAS = 0.8:1.7:0.5 had higher methane yields (134 ± 15 ml CH₄/gTVS) than blends with FW/YW/WAS = 1:1:1. The aim of the study conducted by Rattanapan et al., (2019) was to test biogas production from the co-digestion of food waste (FW) and domestic wastewater under mesophilic (35 ± 1 °C) and thermophilic (55 ± 1 °C) conditions. The highest biomethane potential, 0.78 ml CH₄·mgVS⁻¹, was obtained with a food waste to domestic wastewater ratio of 10:90 w/v at mesophilic temperatures. Tixeira et al., (2021) used domestic waste coffee grounds (DSCGs) that came from the infusion of coffee and industrial waste coffee grounds (ISCGs) co-digested with food waste (FW). The reactors were fed with SCGs in the proportions of 0%, 25%, 50%, 75% and 100% dry weight, using a substrate/inoculum ratio of 1. BMP tests were performed for 45 days at mesophilic temperatures (35 ± 2 °C). BMP levels were highest with 25% DSCG (0.345 Nm³ CH₄/kgTVS), 25% ISCG (0.351 Nm³CH₄/kgTVS) and 75% DSCG (0.301 Nm³CH₄/kgTVS) samples. On the other hand, the 75% ISCG sample had a low percentage of BMP (0.188 Nm³CH₄/kgTVS), due to the release of inhibitory compounds as the percentage of added SCGs increased. Megido et al., (2021) tested the anaerobic digestion, in thermophilic conditions (55 °C), of blends of food waste (FW) from supermarket scraps. The tested matrices were bakery products, butchery waste, cooked meats and cheeses, fish waste, fruit and vegetables. In addition to the different mixtures, different types of digesters were tested, including laboratory-scale induced bed reactors (IBRs) and fully stirred tank reactors (CSTRs), at

different organic loading rates (OLRs), i.e., 3.0, 3.6 and 4.6 kg of volatile solids (VSs) per m³ of reactor a day. Regardless of the type of reactor used, an OLR of 3.6 kgTVS/ m³/day was optimal, achieving up to 48.1% more methane production per kg of waste treated compared to the other OLRs tested. Overall, there were no statistically significant differences (p-value < 0.05) between IBR and CSTR performance at the same OLR. However, at the optimal OLR, the IBR achieved an average methane production of 1.5 l CH₄/l_{reactor}/day (426.7 L CH₄/kgTVS) and the highest TVS removal (89.0% in average). This reactor obtained 22.1% more CH₄ than the CSTR and the highest biogas methane content (66.9% CH₄). Beyond food waste, several authors focused on the recovery of agrifood by-products for the production of biogas and biomethane. Indeed, Vitez et al., (2020) investigated the possibility of using waste corn kernels, peas, crushed corn kernels, green beans, mixed vegetables (broccoli, cauliflower, peas and carrots), corn leaves and corn husk as co-substrates for anaerobic management. They conducted digestion tests using batch reactors (5 dm³) for 21 days at 42 °C in thermophilic conditions. During this period, the quantity and quality of the biogas produced were monitored. Biogas production after 21 days of hydraulic retention time ranged from 0.6773 m³/kg of organic dry matter (peas) to 1.1108 m³/kg of organic dry matter (mixed vegetables). All substrates had a final biogas methane concentration between 59.43 and 65.97% vol. The production of biogas from crushed maize grain was greater than that produced from substrates with a similar nutrient composition (maize grain). Lin et al., (2011) investigated the biomethane potential of fruit and vegetable waste (FVW) and food waste (FW). Individual anaerobic digestion tests were conducted at the organic loading rate (OLR) of 3 kgTVS/(m³·day) using a laboratory scale CSRT reactor at 35 °C. The optimal mixing ratio was 1:1 for the co-digestion and the methane production yield was 0.49 m³CH₄· kgTVS and the optimal chemical soluble oxygen demand (sCOD) removal efficiencies of volatile solids were 74.9% and 96.1%, respectively. Shen et al., (2013) carried out a similar mix with varying organic load ratios (OLRs) in single-phase and two-phase systems, respectively. Their results demonstrate that single-phase digestion is more effective than two-phase digestion, with a 4.1% increase in CH₄ production at lower OLRs being achieved (<2.0 gVS·l⁻¹·day⁻¹). However, at a higher OLR level (P2.0 gTVS·l⁻¹·day

¹), two-step digestion achieved a higher CH₄ production of 0.351–0.455 l·gVS·l⁻¹·day⁻¹, which was 7.0–15.8% greater than that of the single-phase digestion. Moreover, the two-step digestion demonstrated more stable functioning and a greater OLR processing capacity. Furthermore, bioenergy recovery revealed that the two-phase system presented a higher bioenergy yield overall than the single-phase one.

Benalia et al., (2021) evaluated the production of biogas and biomethane from olive mill wastewater by testing blends containing 0% (control), 20% and 30% v/v olive mill wastewater (OMWW) in a reactor under mesophilic conditions. Their research highlighted the production of greater quantities of biogas (80.22 ± 24.49 NL·kg·TVS⁻¹) and methane (47.68 ± 17.55 NL·kg·TVS⁻¹) using 30% v/v OMWW. Zema et al., (2018) evaluated methane production through anaerobic digestion, in mesophilic conditions, of industrial orange peels using a pilot plant (84 l) with semicontinuous feeding at an increasing organic loading rate (OLR) and content of essential oil (EO) until the inhibition process was complete. The highest daily specific methane yield was achieved at an OLR of 1.0 gTVS·l⁻¹ and EO of 47.6 mg·l⁻¹ d⁻¹. Beniche et al., (2017) proposed mixing food waste (FW) with leaves and stems of cabbage and cauliflower (CCF) at different carbon/nitrogen (C/N) ratios. Excellent results were obtained during the study with a C/N ratio = 45. The methane yield was 475 mL CH₄/gTVS, with an organic loading rate (OLR) of 0.06 kg of VS/m³·h for the CCF and FW mixture (CCF + FW).

2.14.4 Sewage sludge

Sewage sludge is the main residue of purification treatments, i.e. a concentrated suspension of solids of various organic and inorganic nature and with a variable percentage of total solids depending on the process that generated it. Sewage sludge is mainly produced in sedimentation processes. It can be divided into categories:

- 1) Primary sludge: sludge produced in primary sedimentation.
- 2) Secondary sludge (or biological sludge): sludge produced in secondary sedimentation.
- 3) Mixed sludge: mixture of primary and secondary sludge.

There is another characterisation depending on the secondary treatment, in fact, secondary sludge can result from treatments with suspended cultures (recycled or surplus activated sludge), with attached cultures (leachate bed sludge, bio-disk sludge, ect.) or even from mixed treatments.

Sewage sludge has a high content of volatile solids (TVS) and a high content of dissolved salts (N, P₂O₅, K₂O) and a low content of total solids (TS) (De Feo et al., 2013).

2.14.5 Organic Fraction of Municipal Solid Waste (OFMSW)

OFMSW, or Organic Fraction of Municipal Solid Waste, is all organic material resulting from the separate collection of municipal solid waste. OFMSW includes food leftovers and waste, food preparations and assimilable fractions in general, such as food paper soiled with food leftovers. From a statistical and environmental point of view, it is very significant that OFMSW now accounts for 30 to 40% of the weight of municipal solid waste. This type of material, which is biodegradable, is mixed with other fractions such as pruning waste, dry vegetable residues and sent to anaerobic digestion plants (Perin et al., 2019). The collection and reuse of organic waste material is a crucial measure towards the accomplishment of the prescribed goals of proper waste disposal (Legislative Decree 152/06) and, minimising the amount of organic waste directed to landfills (Legislative Decree 36/03), along with its environmental consequences.

2.15 Choosing biomass

The choice of a biomass depends on several evaluation factors; the most important are:

- 1) Chemical-physical characteristics and relative methanogenic potential.
- 2) Type and availability in terms of quantity and continuity of supply.
- 3) Economic value of the substrate and costs derived from its use.

The amount of biogas that can be produced is closely related to:

- 1) The composition of the substrate (quantity and type of carbohydrates, lipids and proteins in the substrates).
- 2) The presence or absence of lignin and cellulose (molecules that are difficult to degrade).
- 3) The grain size.

Therefore, the following parameters must be assessed before introducing a biomass into the feeding plan of a digester:

- 1) pH
- 1) Total Solids (TS)
- 2) Total Volatile Solids (TVS)
- 3) Total Kjeldahl Nitrogen and ammonium
- 4) Chemical Oxygen Demand (COD)
- 5) Potential biogas production and relative methane percentage.

In Chapter 3, all the parameters for evaluating and characterising substrates will be described in detail.

2.16 The digestate and its use

Besides biogas, digestate is a product of anaerobic digestion (AD) and represents the effluent or digested substrate that is removed from the AD reactor (digester) after biogas recovery. Digestate usually appears liquid, but can also be a solid, palpable material when it comes from, for example, a dry AD process. During the biogas process, the substrate, which can be a mixture of several substrates (co-digestion) or a mono-digestion, is retained in the digester for several weeks.

During this time it is sequentially decomposed by a series of microorganisms through a complex biochemical process in anaerobiosis. The digested substrate is removed from the digester tank and becomes digestate, which is stored in special containers to be used again or used in agriculture. In fact, digestate is considered an excellent agricultural soil conditioner and also has excellent fertilising properties for plants, based on a rich content of plant macronutrients, including nitrogen (N), phosphorus (P), potassium (K) and sulphur (S), various micronutrients and also organic matter. Digestate is normally applied as fertiliser to crops without the need for further processing (Drogs et al., 2015).

2.17 Pre-treatment of agri-industrial waste

Wastes from food processing and industry still have a high content of bioavailable molecules that can be readily metabolised by the bacterial consortium to produce large quantities of biomethane through anaerobic digestion; they are the best raw material as they constitute an excellent substrate (Vijayakumar et al., 2022).

If these large quantities of waste are not collected and transformed into energy or animal feed, they inevitably end up in landfills. But if they are intercepted, they can be used as perfect substrates for anaerobic digestion and produce bio-methane.

The origins of these types of substrates can be diverse, mainly from the agri-industrial production chain. But not only that, the entire food processing and sales sector also produces huge amounts of food waste and scrap. The same applies to food products of animal origin, such as meat and meat products, but also the entire dairy sector produces huge amounts of waste. In addition, all places where food is prepared and served, such as restaurants, canteens, etc., should be included.

Last but not least, there is a mass of food waste that accumulates daily in consumers' homes. If these large quantities of waste are not collected and turned into energy or animal feed, they inevitably end up in landfills. But if they are intercepted, they can be used as perfect substrates for anaerobic digestion and produce bio-methane.

However, some substrates can be problematic in terms of decomposition rates, as they can present several issues including:

- They may contain chemicals that inhibit the growth and activity of microorganisms. For example, the polyphenol content in OMWW from olive oil mills can inhibit or even stop the methanogenic bacterial consortium (Manso, T., Marta, L. and de Migue., T., 2022),
- They create physical problems of sedimentation, foam or lump formation and block impellers and pipes in biogas plants,
- Their molecular structure is poorly accessible to microorganisms and their enzymes (e.g. due to their highly crystalline structure or low surface area).

Many of these technologies, used in the biogas energy field, were developed by the wastewater treatment or bioethanol industry (Montgomery, Lucy F.R and Bochmann, G., 2014).

The first waste treatment and screening step is the screening of the various substrates is essential to remove other types of waste from the biogas chain, such as inert materials, plastics and packaging and stones. This first screening step is necessary to remove inorganic substances that may enter the reactor.

Inorganic material can in fact cause blockages and shutdowns of the plant, or simply fill the reactor volume with inert material, greatly reducing the useful volume of the reactor. In addition, this type of initial screening also allows the recovery of other recyclable materials, such as plastic and metal.

2.17.1 Particle reduction, mechanical pre-treatment

In order for these nutrients to be immediately attacked and transformed by the bacterial consortium, it is necessary to reduce the size of these wastes, as their grain size can compromise biogas production. The larger the substrates, the greater the likelihood of digester clogging. For this reason, it is recommended to significantly reduce the grain size of the waste. By reducing the waste particle size and increasing the surface area of the waste, the biomolecules are made more readily available to the bacterial consortium, thus reducing the start-up time of the digestion process, biogas production is greatly improved and retention times are shortened.

When the waste particle size is 25 μm , the methane yield is higher, so the particle size of the material is directly related to the difference in the total number of microbes exposed (Sebola., M., Tesfagiorgis, H. and Muzenda, E., 2015; Vijayakumar et al., 2022). Mechanical pre-treatment consists of subjecting the waste to high mechanical stress by cutting or squeezing. The basic process, however, only involves reducing the particle size of the waste.

The problem with this type of pre-treatment is the wear and tear to which the machinery is subjected. For this reason, it is best to have robust and reliable equipment, both to avoid damage to property and objects, and to avoid the forced closure of the plant (Dahunsi et al., 2019). Mechanical pre-treatment is performed by mills and makes the substrate pieces smaller or squeezes them to break the cell structure, increasing the specific surface area of the biomass (Figure 2.13).

This offers a greater possibility of enzymatic attack, which is particularly important for lignocellulosic substrates. Reducing particle size not only increases the rate of enzymatic degradation, but can also reduce the viscosity in digesters and can reduce the problems resulting from particle settling or foam formation. One of the main disadvantages of mechanical pre-treatment is that mills can be damaged by inert materials in the substrate, such as stones or pieces of metal, and repairs to the equipment can be very expensive (Montgomery, Lucy F.R and Bochmann, G., 2014).

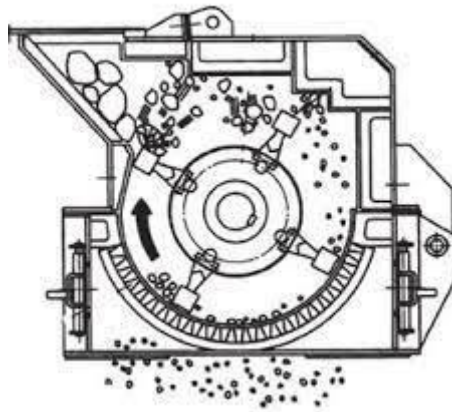
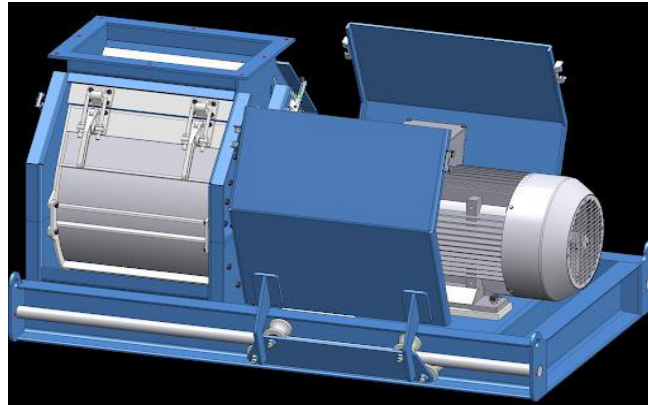

Figure 2.13 An example of a hammer mill for size reduction.

To carry out size reduction (crushing and grinding, for example) of the sample, a test screen with a 10 mm mesh size is used. In the presence of fibrous or other material that is difficult to reduce in size, it must be cut, broken or otherwise processed to a particle size of less than 10 mm. In this case, the size reduction method has a decisive influence on the grain size range. If the material heats up too much during size reduction, this can result in the loss of volatile components (V. Verg, S. Substratcharakterisierung 2006). Particle size fractionation can be performed, also, with an instrument called a multi-sieve vibrator with gradually finer sieve sizes (Figure 2.14). Pre-treatment technology is the main stage of biogas production. This step helps the consortium of bacteria to degrade the organic component more easily and, consequently, make it more available for bacterial enzymes.



Figure 2.14 Example of multi-sieve vibrator with gradually finer sieve sizes

2.17.2 Ultrasound pre-treatment

The term sonication means the use of ultrasonic acoustic waves where there is the need to disintegrate cells, homogenize, emulsify, degrease and disperse products in the biotechnological and chemical sector. This type of pre-treatment, tested up to now only in laboratory studies, involves the use of ultrasound waves on small quantities of sample. This type of pre-treatment can be carried out with a power ranging from 0-400 w up to 20 to 30 kHz (Atelge, M.R. et al., 2020).

For example Zerrouki et al., (2021) used ultrasound as a pre-treatment as a potential technique for the solubilization of organic material. They used fruit juice effluents in the anaerobic batch reactor in their study. The effectiveness of the ultrasonic pre-treatment was evaluated at a low frequency of 20 kHz and at different sonication times (20, 40 and 60 min). Compared to the control, the amount of biogas produced increased by 47,57 and 60% for sonication times of 20, 40 and 60 min, respectively. The methane content of the biogas produced was approximately 59% in the control and 64% in the case of ultrasonic effluent for 60 min. The specific energy input can be calculated using the following formula (Oleszek, M. and Krzemi, I., 2021):

$$E_i = (P/t) = (V/TS)$$

Where:

P: is power (W);

t: is exposure time (s);

V: is sample volume (l);

TS: is content of total solids in the sample (kg/l).

2.17.3 Thermal pretreatment

In pure thermal pre-treatment, the substrate is heated (typically 125 to 190 °C) in a pressurised environment and kept at a constant temperature for up to one hour. Substrates with a low water content require an addition of water prior to heat treatment. The conjugate action of the presence of heat and water allows the hydrogen bonds that hold crystalline cellulose and lignocellulose complexes together to break, causing the biomass to swell (Garrote et al., 1999).

Thermal pretreatment is often carried out with the addition of chemicals or in combination with mechanical pretreatment. An example of large-scale thermal pretreatment is TDH (“Thermo-Druck-Hydrolyse” sometimes known as 'thermal hydrolysis' shown in the figure 15). In this process, substrates such as food waste are diluted to about 10-15% substance (Schieder et al., 2000). If the substrate is bulky, it is crushed and then fed into the TDH reactor. The reactor is placed at a pressure of 20-30 bar and a temperature of 170-200 °C for 20 minutes.

The heat used to enable the thermal process, is recycled as it can be recovered from the material leaving the reactor and material leaving the reactor and also from the exhaust gas of the process. Thermal pretreatment is only effective up to a certain temperature. The maximum temperature varies for different substrates and using AD testing was found to be 175°C for sludge (52% increase in methane production). (Distefano and Ambulkar, 2006), 190 °C for cultures (Dinglreiter, U., 2007), and 160 °C for spent grains from brewers (Bochmann et al., 2010).

However, these values depend on the pre-treatment time. Even the use of microwaves can be used as a thermal pre-treatment, but this type of pre-treatment is not carried out on a large scale, presumably due to high costs.

2.17.4 Chemical pretreatment

Waste can be pre-treated with both acidic and alkaline chemicals. Pretreatment involves the use of these substances, at different concentrations.

For lignin-containing materials, highly corrosive substances are used, which are capable of damaging the lignocellulosic cell walls, dissolving them in blockages for anaerobic digestion. This process allows a significant increase in biogas production (Zhang et al., 2007). The solution can be prepared with different portions of CaO, NaOH and KOH for alkaline pretreatment and with acids such as HCl, H₂SO₄, H₃PO₄ and HNO₃ for acidic pretreatment (Atelge, M.R et al., 2020). For example (Qiao et al. 2022) used potassium ferrate (K₂FeO₄) as a chemical pretreatment to increase sludge hydrolysis and eliminate antibiotics in activated waste sludge (WAS), as their presence can inhibit or kill the bacterial consortium.

2.17.5 Electrokinetic disintegration pre-treatment

High intensity electric fields are used for a variety of processes in modern biotechnology. Electrokinetic disintegration is mainly used for sewage sludge treatment, where the main inhibiting factor for good anaerobic digestion is the presence of aggregated lumps of microorganisms (flakes) and particles in the sludge. Furthermore, the use of high-intensity electrical impulses has the purpose of disintegrating the cell walls, making it easier for the hydrolytic bacterial consortium to access nutrients. Cell membranes are considered bio-capacitors containing low permittivity dielectric material which maintain an electrochemical gradient on both sides of the membrane. This gradient is generated due to an excess of negative ions accumulating on the inner surface of the membrane and an equal number of positive ones outside the cell. A transmembrane potential called the resting potential is formed across the cell membrane. After being exposed to a sufficiently high external electric field, the membrane ions migrate towards the walls causing a potential difference.

The electric field induces an additional transmembrane potential, greater than the natural potential of the membrane, which is unevenly distributed over the surface Figure 2.15. Cell membrane disruption, also known as electroporation, occurs when

the overall transmembrane potential (sum of induced potential and resting potential) reaches a threshold value, the critical transmembrane potential. Depending on the strength of the electric field and the intensity of the treatment, the rupture of the membrane can be reversible or irreversible. When the increase in membrane permeability is only temporary and the membrane regains its initial selective permeability once the electric field ceases, electroporation is said to be reversible. Otherwise, if the cell dies, the membrane rupture is irreversible (Rupc et al., 2020; Salerno et al., 2008).

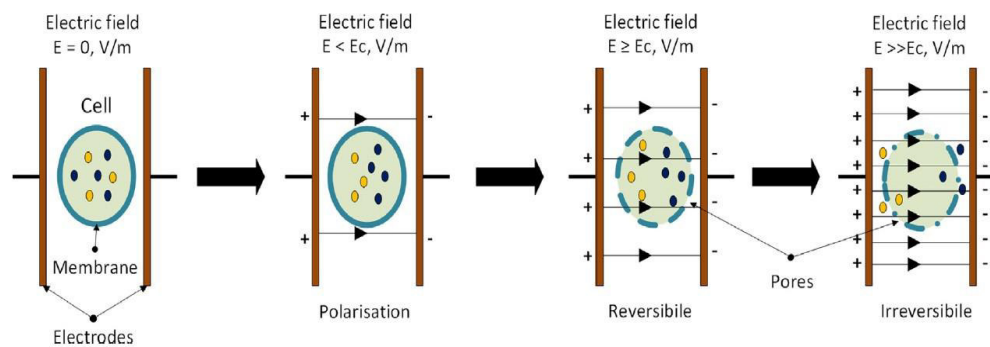

Figure 2.15 Reversible and irreversible electroporation.

The application of this pre-treatment is possible with the use of *BioCrack* (Figure 2.16 and 2.17), it is the tool that allows the use of this waste pre-treatment technique. Simplifying, the instrument is composed of an electric pulse generator and a high voltage power supply and the treatment chamber Figure 2.17.

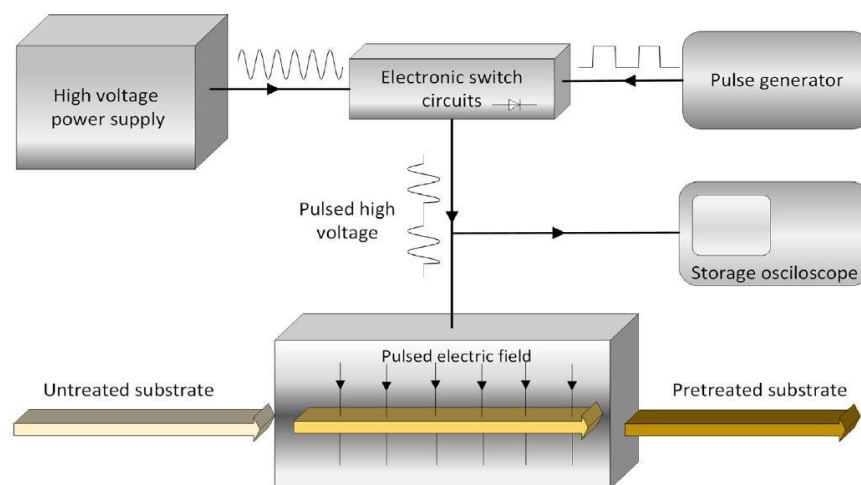

Figure 2.16 Image simplifying the operation of the *BioCrack*.



Figure 2.17 BioCrack instrument.

2.17.6 Biological treatment

Biological pre-treatment is the most promising and economical technology for biogas production, and this treatment technology is also environmentally friendly (Vijayakumar et al., 2022). Biological pretreatment is the most promising and economical technology for biogas production, and this treatment technology is also environmentally friendly. is a method in which microorganisms are involved, it is used to break down cross-linked structures in substrates with enzymes.

The main function of biological pretreatment is the degradation of materials in a simple way using microbes, enzymes and fungi. The general advantages of biological pre-treatment over chemical or thermal pre-treatment is that biological pre-treatment can take place at low temperature without the use of chemicals. A disadvantage is that it can be slower than non-organic methods (Atelge, M.R. et al., 2020).

2.17.7 Combined processes

Combined processes use a combination of processes, making their effect more effective. An example of a combined process is steam explosion.

2.17.8 Steam explosion

Steam explosion makes substrates more digestible through a combination of heating and a sudden change in pressure. The substrate is heated in a closed system to a temperature of 160-220°C, causing a pressure increase. After a retention time of about 5-60 minutes, pressure is abruptly released. This sudden drop in pressure causes intracellular water to evaporate very quickly, resulting in a phenomenon known as a vapour explosion or phase explosion (Montgomery, Lucy F.R and Bochmann, G., 2014).

2.17.9 Extrusion

Extrusion is a process in which the material is fed into the extruder and conveyed by screw along a pipe, where it is exposed to high pressure and high temperature (Figure 2.18). The sudden drop in pressure, when the substrate leaves the extruder, favors the breaking of the substrate, especially if fibrous products are used (straw and vegetable waste, etc.). Depending on the required final consistency, the substrate can be subjected to pressure up to 300 bar at temperatures of 60 to 300°C (60 to 70°C generated by friction, higher temperatures if a heater is used).

Extrusion effectively breaks down the cellular structure of biomass, which results in faster methane production, which in turn facilitates higher organic loading rates (FNR, 2016; Lehmann, 2011; Montgomery, Lucy F.R and Bochmann, G., 2014)



Figure 2.18 Extrusion equipment and plant waste undergoing the extrusion process.

2.17.10 Thermochemical pretreatment

This type of pre-treatment involves the combined use of different types of bases and acids and high temperatures (60 to 220°C). As with other pre-treatments involving heat, temperatures above about 160°C, particularly in combination with acids, show a decrease in methane production, depending on the input material (Delgenès et al., 2000; Distefano, T.D. and Ambulkar, A., 2006; Penaud et al., 1999).

There are many studies on thermochemical pretreatment in the literature. In general, the chemicals used are many including: H₂SO₄, H₂O₂, NaOH or HCl at different concentrations. While the temperature can vary considerably, from 60 to 220°C. Although thermochemical pretreatment has been tried several times on a pilot scale, to our knowledge there are currently no examples of large scale thermochemical pretreatment of substrates for biogas production (Montgomery, Lucy F.R and Bochmann, G., 2014).

2.18 Anaerobic digestion of food waste and agrifood by-products undergoing pretreatment and novelties in the experimental field

In this section, studies on the pretreatment of substrates used in anaerobic digestion and new plant innovations are discussed.

Chaurasia et al., (2021) investigated the effect of some pretreatments on fruit, food and vegetable wastes. The effect of alkaline, hydrothermal, thermal and ultrasonic pretreatment of fruit, food and vegetable waste (FFVW) on anaerobic co-digestion (AcoD) was tested for the reduction in total solids (TSs), volatile solids (TVSs) and biogas/methane production. The mesophilic anaerobic co-digestion of FFVW pretreated with cattle manure was carried out in a 1 l batch digester on a laboratory scale for 30 days at a temperature of 40 ± 2 °C. A reduction of 16.89% TSs and 19.44% VSs was observed during the ultrasonic pretreatment, while 106.81 ml of biogas/gTVS and 29.92 ml of CH₄/gTVS were generated. In addition, alkaline pretreatment showed a significant improvement in biogas production, but was less economical. El Gnaoui et al., (2019) used food waste (FW) as a substrate for anaerobic digestion by subjecting it to heat pretreatment (HPT) of variable duration. This study investigated the effects of HPT on the physicochemical properties and the improvement in methane yield (MY). As a function of temperature and treatment time, HPT reduced the percentage of TVSs compared to the raw FW. In addition, anaerobic digestion (AD) of pretreated FW was tested at 100 °C for 30 min, and the MY was 382.82 ml STP CH₄/gTVS, 23.68% higher than that of untreated food waste. Sun et al., (2024) examined eight process variables in an agricultural biogas plant, including biomass type, reactor/feeding, volatile solids, pH, organic load rate, hydraulic retention time, temperature and reactor volume; artificial neural networks (ANNs) were used to analyse biogas production rate. Variables were selected using the cuckoo optimisation algorithm (COA), the multiverse optimisation algorithm (MVO), the alloy sampling algorithm (LCA), the evaporation water cycle algorithm (ERWCA), stochastic fractal search (SFS) and learning-based optimisation (TLBO). These models are based on bio-inspired algorithms and demonstrate promising outcomes in forecasting biogas production results. Beltramo et al., (2019) used ANN technology to predict the production rate considering 15 process variables. Concentration of volatile fatty acids, TS, TVS,

acid detergent fibre, acid detergent lignin, neutral detergent fibre, ammonium nitrogen, HRT, OLR were measured. They used different algorithms (ant colony optimisation and genetic algorithms) to perform the variable selection. The best results they obtained were those where optimised ANN models with optimised ACO-GA were used. In this case, the prediction error was reduced to 6.24% and the R² increased to 0.90. To develop and test a system for monitoring and controlling variables in the anaerobic digestion (AD) process, Cruz et al., (2019) conducted batch tests under mesophilic conditions (37 °C) with a substrate/inoculum ratio of 1:2. Variables examined included pH and temperature in the liquid phase and pressure, temperature, methane yield and biogas volume in the gas phase. The variables examined included pH and temperature in the liquid phase and pressure, temperature, methane yield and volume of biogas in the gas phase. The developed system based on Arduino produced a cumulative average biogas concentration of 0.67 lCH₄, with a concentration of 51.46%. Meanwhile, Bernardi et al., (2017) developed a prototype for the anaerobic digestion of olive mill wastewater (OMWW), with pH and temperature as variables. The medium-scale, fully automated prototype was equipped with a thermos-regulable heating cover. The digestion chamber was fed with acid and alkaline through two charging lines. Scarcello et al., (2023) implemented control logic to manage the prototype described earlier. The control logic was implemented to keep the temperature and pH values within a certain range to ensure optimum process parameters. The intelligent automation system consists of three PLC units that manage sensors to collect temperature and pH data for process control and pressure and flow sensors to determine biogas production. A remote control interface was designed for manual or automatic control of the plant. The interface also allows process parameters to be set and process progress to be monitored. Farhat et al., (2018) examined thermal pretreatment of municipal sewage sludge (MSS) in combination with anaerobic co-digestion of olive processing wastewater (OPW) to improve the disintegration of complex organic matter and its bioconversion into biogas. The authors conducted an anaerobic co-digestion of pretreated municipal solid waste (PMSS) mixed with pressurised organic wastewater (OPW) and examined the effect of increasing the percentage of OPW on biomethane potential (BMP). The best results were obtained

with mixtures of PMSS/OPW (80%/20% and 70%/30%), which were also tested in batch reactors. In conclusion, the thermal pretreatment of MSS and the addition of OPW significantly improved the methane yield (50–160%) and the stability of the waste. Farhat et al., (2018) also tested the co-digestion of waste-activated sludge (WAS) combined with olive processing wastewater (OPW). Various WAS/OPW ratios were examined (100% WAS, 90% WAS/10% OPW, 80% WAS/20% OPW, 70% WAS/30% OPW, 60% WAS/40% OPW and 50% WAS/50% OPW) in sequential anaerobic batch reactors (ASBRs). Optimal results were achieved with ratios of (WAS/OPW) 90%/10% and 80%/20%. Zema et al., (2018) conducted experimental batch tests under mesophilic and thermophilic conditions on the anaerobic digestion of olive mill wastewater (OMWW) mixed with other agri-industrial by-products. Tests were conducted to determine the potential biogas production and sensitivity of the process to inhibitory compounds. The mixtures contained varying percentages of OMWW, digested manure and citrus peels. The results presented showed that mixtures containing MSW percentages above 20% (v/v) had low methane yields due to having higher concentrations of polyphenols (PPs) and/or volatile fatty acids (concentrations above 0.8 g kg⁻¹ and 2.4 g l⁻¹, respectively). The addition of other substrates, such as citrus peels, in other tests may have induced synergistic PP and essential oil (EO) inhibition effects on microbial consortium growth. Furthermore, their study revealed that thermophilic processes were more sensitive to these inhibitory compounds than mesophilic ones. Tufaner et al., (2020) tested the use of primary anaerobic digestion and the Fenton process to treat olive processing wastewater (OPW). The tests were conducted on a laboratory scale using a rising flow anaerobic reactor (UASB) under mesophilic conditions (36.5–37 °C) with an organic loading rate (OLR) of 1 kg COD m³ d⁻¹ and an HRT of 10 days. During the experiment, a COD removal of 76.8% was achieved. The effluent from the anaerobic treatment was further treated via the Fenton treatment process, using Fe²⁺ and H₂ O₂.

Fenton treatment achieved a COD and colour removal of 91% and 96%, respectively, under optimised conditions. To remove 1 g of COD from anaerobically treated wastewater, 19 mg of Fe²⁺ and 250 mg/l H₂O₂ were required. Thanks to the

Fenton process, approximately 98% of the COD of diluted raw sewage could be successfully treated at a ratio of 1:8.

3. ANAEROBIC DIGESTION OF AGRI-INDUSTRIAL BY-PRODUCTS AND FOOD WASTE FOR BIOMETHANE PRODUCTION: MATERIAL AND METHODS

Experimental trials of anaerobic digestion of agri-food by-products and food waste were conducted in batches and in a continuous stirred tank reactor on a laboratory scale, under mesophilic conditions. The research activity took place between the laboratories of the *Agricultural and Food Mechanics Laboratory of the Department of Agriculture of the Mediterranean University of Reggio Calabria* and the *Department of Agri-biotechnology (IFA Tulln) of the University of Natural Resources and Life Sciences in Vienna*. Further details are given below. To carry out the tests, various agri-food by-products and food waste were taken into account, as shown in table 3.1 below. In addition to these products, digestate was also considered. In addition to these products, digestate, which was prepared by mixing digestate from three different industrial biogas plants, was used as an inoculum and buffer substrates. Four experiments were conducted, listed below:

1. Mono-digestion, conducted by BMP assay under mesophilic conditions (37°C) with a retention time of approximately 30 days, of eleven different substrates. Three replicates were considered for each thesis, for a total of 33 reactors.
2. Co-digestion, conducted by means of a BMP test under mesophilic conditions (37°C) with a retention time of approximately 40 days, of four different mixtures consisting of 80% curd +20% other substrates. Three replicates were considered for each thesis, for a total of 15 reactors.
3. Co-digestion, conducted via BMP test under mesophilic conditions (37°C) with a retention time of approximately 30 days, of three different mixtures consisting of 70% curd+15% bakery products+15% other substrates. Three replicates were considered for each thesis, for a total of 12 reactors.

4. Continuous anaerobic co-digestion of a mixture of dairy industry waste and meat products using daily fed CSTR reactors. The trial lasted 48 days and each reactor was considered as a replica.

Table 3.1 Samples of agrifood by-products and food waste used in the trials.

Food waste category	Substrates	Provenience
Cereals and farinaceous food waste	Bakery products	Supermarket
	Cooked pasta	Laboratory kitchen
	Cooked rice	Laboratory kitchen
	Oatmeal	Plant-based beverage processing waste
Dairy industry by-products	Whey	Self-produced
	Non-edible curd	Self-produced
	Expired mozzarella cheese	Supermarket
Fruit and vegetables waste	Ready to eat vegetables	Supermarket
	Household vegetables waste	Supermarket
	Expired sausage	Supermarket
Meat product waste	Expired sausage	Supermarket

3.1 Physical-chemical characterization of the matrices

Before conducting the static BMP tests, it is necessary to characterise the substrates and inoculum considering physical and chemical properties, in accordance with the VDI 4630, in order to adequately set-up the matrix content in the reactor, address the suitable process parameters, and avoid inhibiting effects.

Particularly, pH was measured using pH probe (pH-meter XS PH 8+ DHS), total solids TS (%) at 105 °C were determined using a moisture analyzer (Ohaus, MB120), total volatile solids TVS (%) were determined after ignition at 550 °C using a muffle furnace (MF400X0401) (Epa, U.S., and O.W. Office, 2001). Chemical oxygen demand (COD) ($\text{g}\cdot\text{l}^{-1}$) was measured following the COD measurement method for high concentration samples, the samples were then titrated using (Metrohm, Dosimat plus). In addition, total polyphenols (PPs) were measured according to Folin Ciocalteu (Vernon et al. 1999), method total kjeldahl nitrogen (TKN) and ammonium were quantified using an auto-distiller (B.U.C.H.I, Autokjeldahl unit k370). The results for both are expressed in $\text{g}\cdot\text{kg}^{-1}$.

3.1.1 pH determination

The pH by definition is the negative decimal logarithm of the ion concentration H^+ :

$$pH = -\log [H^+]$$

The pH provides an indication of the stability of the process, as its variation is associated with both the buffering capacity of the system by the reaction medium and changes in the equilibrium between the species participating in the trophic chain of the microorganisms involved in the process. For pH values between 6.5 and 7.5, the digestion process is generally considered stable. The measurement of this parameter can indicate whether there are unbalanced conditions in the system, but only with a certain delay in relation to the evolution of the buffering effect of the medium (Cecchi et al., 2005; V. Verg, S. Substratcharakterisierung 2006;).

A pH meter (CRISON pH-Meter GLP 21⁺) was used for pH determination. Initially, the instrument was calibrated with buffer solutions of known pH (pH 7.00, pH 4.01 and pH 11). Once the instrument was calibrated, it was possible to proceed with the measurement of the pH of the samples, by inserting the electrode into the sample and proceeding with the self-reading of the value on the instrument display. The measurement was repeated in triplicate for each sample.

3.1.2 Determination of Total Solids and Total Volatile Solids

In accordance with *Method 1684* (Epa, U.S., and O.W. Office, 2001) for the determination of Total Solids and Volatile Solids, the following procedure was carried out. For the determination of Total Solids, the porcelain capsules were placed in a muffle furnace set at 105°C for approximately one hour, in order to remove the moisture present. Subsequently, the capsules were taken out and left to stand inside a desiccator, where silica gel is present, until completely cooled.

Once cooled, they were removed and moved to the analytical balance to measure the weight of the samples. Having calibrated the balance with the capsule empty, 5 g of sample was weighed (Figure 3.1).



Figure 3.1 Fresh samples to be dried at 105°C.

The capsules containing the samples were placed inside a muffle furnace set at 105°C for four hours. At the end of the thermal cycle, the capsules were removed from the oven and placed inside a desiccator until completely cooled.

Finally, it was possible to weigh the samples and calculate the amount (expressed in mg) of the totals using the following formula:

$$\% \text{ Total Solid} = \frac{W_{total} - W_{dish}}{W_{sample} - W_{dish}} * 100$$

Or

$$\frac{\text{mg Total Solids}}{\text{kg sludge}} = \frac{W_{total} - W_{dish}}{W_{sample} - W_{dish}} * 1.000.000$$

Where:

W_{dish} = Weight of dish (mg);

W_{sample} = Weight of wet sample and dish (mg);

W_{total} = Weight of dried residue and dish (mg).

While for the determination of Total Volatile Solids (TVS), the capsules, containing the samples used for the determination of total solids, were placed inside the muffle furnace set at 550°C for four hours. Once the thermal cycle of combustion of the samples was finished, the capsules were removed from the muffle furnace and placed inside a desiccator. When the capsules had cooled down, it was possible to weigh them and calculate the percentage of total volatile solids using the following formula:

$$\% \text{ Total Volatile Solid} = \frac{W_{total} - W_{volatile}}{W_{sample} - W_{volatile}} * 100$$

Or

$$\frac{\text{mg Total Volatile Solids}}{\text{kg sludge}} = \frac{W_{total} - W_{volatile}}{W_{sample} - W_{volatile}} * 1.000.000;$$

Where:

W_{dish} = Weight of dish (mg)

W_{total} = Weight of dried residue and dish (mg)

$W_{volatile}$ = Weight of residue and dish after ignition (mg).

3.1.3 Ammonium nitrogen and Total Kjeldahl Nitrogen determination

For the determination of ammonia and Total Kjeldahl Nitrogen, the method indicated by the instrument manufacturer (*B.U.C.H.I Auto Kjeldahl Distillation Unit K-370*) was followed. The $\text{NH}_4^+\text{-N}$ can be analysed by automated laboratory systems (see Figure 10) according to *US-American standard*.“APHA 4500- $\text{NH}_4^+\text{-N}$ Nitrogen” (APHA, 1998) or the German industry standard DIN 38406-5:1983-10 (1983) based on $\text{NH}_4\text{-N}$ concentration.

For the measurement of ammonium ($\text{NH}_4^+\text{-N}$), the test tubes were calibrated and approximately 1 gram of sample was weighed and RO- H_2O was added.

The test tubes containing the sample were then placed in an ice bath before being analysed (Figure 3.2). For the quantification of ammonium, it was sufficient to follow the method of the instrument (see method MANUAL BÜCHI DISTILLATION DEVICE Autokjeldahl Destillationsgerat Unit K-370, pag.92-95).

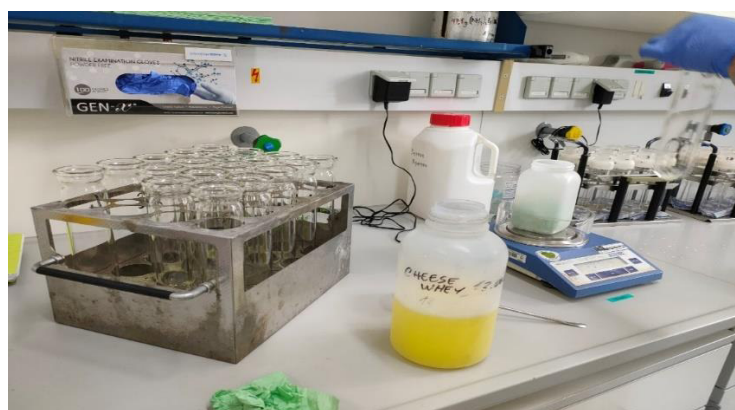

Figure 3.2 Sample preparation for ammonium and TKN analysis.

For the measurement of TKN or Total Kjeldahl Nitrogen, two test tubes filled with RO- H_2O alone were prepared, while for the analysis of the samples, approximately 1 g of sample was weighed into the test tubes. 10 ml of RO- H_2O and one tablet of Kjeldahl reagent were added to the samples. Subsequently, 20 ml of sulphuric acid at a concentration of 98% was added. The test tubes were placed on a heating block for thermal treatment (Figure 3.3).

Once the thermal process was finished, the samples were allowed to cool and then, following the method specified by the manufacturer of the auto-distiller (see method MANUAL BÜCHI DISTILLATION DEVICE Autokjeldahl

Destillationsgerat Unit K-370, pag.106-108), total Kjeldahl nitrogen was determined.



Figure 3.3 Samples subjected to thermal cycling for TKN analysis.

MANUAL BÜCHI (DISTILLATION DEVICE) (Autokjeldahl Destillationsgerat Unit K-370)

Always (that means: every time!) wear safety goggles in lab, especially when working with NaOH, acids (even diluted ones) or other dangerous substances!

Always use gloves, when working with dangerous substances or those where you don't know whether they are dangerous or not.

Checklist (very short description)

- Turn on the unit
- Turn on cooling water (as far as it will go)
- Rinse pH electrode and place in the "boric acid cell"
- Do a "priming"
- Enter and measure of samples
- Do a "Cleaning"
- Manually dose H₂O into the flask
- Turn off cooling water and distillation unit
- Rinse pH electrode and store it in KCl flask

The distillation device has 3 modes

Configurator: here samples and blanks are entered

Operator: starting samples and blanks; preparation of the equipment (preheating), priming, cleaning)

Status: displays current status (several pages); display result of last measurement

To switch between these modes, press "Mode".

1. Starting the distillation unit

Turning on: After flipping the on/off switch, the device heats up automatically and the display shows "Preheating". As soon as working temperature is reached, the display shows "Ready".

Turning on cooling water: turn the tap behind the device; turn it as far as it will go. Do not worry if water does not come out of the hose! Water is only led into the distillation unit while distillation is running.

Rinsing of pH electrode: rinse electrode and place it in the “boric acid cell” (“Borsaurezelle”). Be careful not to damage the membrane!!!

2. Preparation of distillation unit

As soon as “Ready” is displayed

Priming:

- Clamp in a clean flask
- Operator System Preparation Priming RUN

3. Entering Samples / Blanks

Configurator → Group → Ammonium/ TKN* “NEW”

In the appearing form enter the following:

	Sample	Blank
Name:	sample name or number	Blank ½
Weight:	what you weighed in (g)	=====
Type:	Sample	Blank
Method:	Ammonium / TKN*	Ammonium / TKN*

*Depends on the analysis done

4. Measuring Samples / Blanks

Operator → Determination → Group → Ammonium / TKN* → chose correct sample/ blank and press “RUN”

For measuring blanks an empty clean flask is used.

5. Reading off values

All values together at the end of all measurements:

Configurator → Data Manager → Result Group → Ammonium / TKN → chose first sample / blank ; “ENTER”. Then navigation with “prev”/“next”.

6. Turning off distillation unit

Cleaning:

Operator → System Preparation → Cleaning → "RUN"

Manual dosing of H₂O (protects valves from drying out)

- "Cleanin" → flask stays in the unit
- Status → press "H₂O" until the hose is covered with water

Turn off cooling water and distillation unit

Rinse the electrode and put it back to the KCl-bottle (3 M KCl)

7. Error messages – Preparation of solutions

H₃BO₃ (-2 %): 100 – 110 g boric acid (cupboard next to the distillation unit) are weighed in a 5 L beaker (measuring pitcher) and completely dissolved in 5 L RO water by using a magnetic stirrer. **Using a funnel**, the solution is then filled in the correct canister.

NaOH (-30%): 3 L 50% NaOH (from the "Technikum") are put into a 5 L beaker (measuring pitcher) and diluted with 2 L RO water. **Under the fume hood** the solution is stirred with a magnetic stirrer until it is homogenised, the nit is filled in the correct canister **by using a funnel and wearing safety goggles.**

3.1.4 Chemical Oxygen Demand (COD) determination

Chemical Oxygen Demand (COD) represents the amount in mg of oxygen required for the complete oxidation by chemical means of the organic and inorganic compounds present in a sample.

The Chemical Oxygen Demand is expressed in mg/l COD, defined as milligrams of O₂ consumed per litre of sample (mg/l O₂). The method involves the oxidation of organic and inorganic substances, present in a sample, by means of a potassium dichromate solution and in the presence of concentrated sulphuric acid and silver sulphate as oxidation catalysts.

The excess dichromate is titrated with a solution of ammonium sulphate and iron (II). The concentration of oxidisable organic and inorganic substances, under the conditions of the method, is proportional to the amount of potassium dichromate consumed. The chloride ion is considered an interferent, as its oxidation can only take place under the conditions of the method used for COD and not under those found in natural waters. Knowledge of COD values, as mentioned above, is necessary both to quantify the organic matter present in the samples and to have a rough estimate of biomethane production. Since each gram of COD present in the sample will approximately give a weight yield of 350 ml of CH₄ (de Zorzi et al., 2014).

The following method was used for its quantification.

Samples were weighed directly into the COD (=VP) tubes. Two 10 ml blanks with RO-H₂O were included in each analysis run. Samples were diluted with approximately 10 ml with RO-H₂O and shaken in order to homogenise the samples. Next, 20 ml of 0.2 M potassium dichromate solution was added and 30 ml of sulphuric acid (conc. with 10 g/l AgSO₄) was slowly added. The tubes were connected to condensers and placed in the preheated heating block until 150°C was reached. The samples were heat-treated for 180 min at 150°C under fume hood (Figure 3.4).



Figure 3.4 Samples thermally cycled 180 minutes at 150°C.

The tubes were allowed to cool down to room temperature. The contents of the test tubes were quantitatively transferred into 250 ml volumetric flasks (Figure 3.5). The flasks were made up to volume (to 250 ml) with RO-H₂O and were shaken until the solution was homogenised.



Figure 3.5 Diluted samples.

Using a pipette, 10 ml of the oxidised and diluted sample was taken and transferred to a clean COD tube and approximately 80 ml was added with RO-H₂O. Subsequently, 10 ml of H₂SO₄ (conc. 96%) was added and made up to 100 ml with RO-H₂O. For titration, 4-5 drops of Iron-indicator were added (ideally the solution should turn yellow-brown, if the colour changes to blue, blue-green or green, the sample quantity must be reduced, an exact titration is not possible).

The samples were titrated with an auto-titrator (Metrohm 87G Dosimat plus) (Figure 3.6) with a 0.06 M solution of iron ammonium sulphate (II) until the colour turned red-brown (Figure 3.7).



Figure 3.6 Metrohm 87G Dosimat plus used for sample titration.

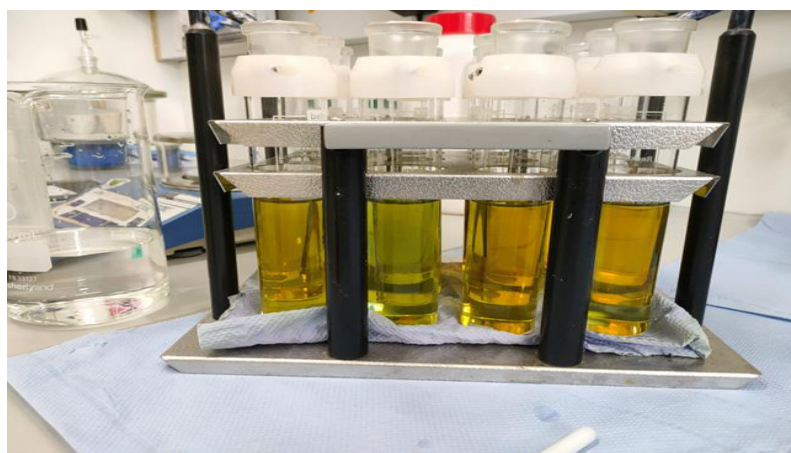

Figure 3.7 Post-titration sample staining.

The whites were then titrated using a 0.06 M iron ammonium sulphate (II) solution until colour change, then 10 ml of 0.02 M mercury sulphate (II) solution was added (whites only) and titrated again with a 0.06 M iron ammonium sulphate (II) solution until colour change.

Calculation of the background (blanks)

$$c = \frac{VV * cD * 6}{VT}$$

Where:

c= concentration of iron ammonium (II) sulphate solution expressed in mol/l;

VV= used volume of potassium dichromate solution expressed in ml;

cD= concentration of potassium dichromate solution in mol/l;

VT= volume of iron ammonium (II) sulphate solution consumed for the titration.

COD Content in the samples

$$P = \frac{c * 8 * 25 * (VB - VE)}{Vp};$$

Where:

P= COD contained in the samples expressed in mg/g;

VB= volume of iron-ammonium (II) sulphate solution consumed for blank titration;

VE= volume of iron-ammonium (II) sulphate solution consumed for the titration of the samples;

Vp= amount of sample expressed in grams.

3.1.5 Determination of Total Volatile Fatty Acids by HPLC

For the determination of Volatile Fatty Acids for analysis by HPLC (Agilent series 1200), it was necessary to subject the samples to extraction and purification. The method used is explained below.

The test samples were subjected to centrifugation, using a centrifuge (put centrifuge name), for 10 minutes at a temperature of 21°C and the speed was set to 3000 rpm. After centrifugation, approximately 1 ml of supernatant was removed using a precision syringe and placed inside a 1.5 ml eppendorf tube. The supernatant taken previously was centrifuged for 10 minutes at room temperature by setting the centrifuge speed to 12400 rpm. Subsequently, 200 µl of supernatant was collected and placed into a new tube.

If the pH of the sample is not in a range between 4 and 6; 760 µl of H₂SO₄ solution must be added. If the pH is above 6, the system is buffered with a 0.05 M H₂SO₄ solution; if the pH is <4, the system is buffered with a 0.025 M H₂SO₄ solution. After the system is buffered, the tubes are homogenised in a vortex (name of vortex). Subsequently, using a stepper syringe, 20 µl of C₁ solution 2% of K₄[Fe(CN)₆]-3H₂O, (Potassium hexa-cyano-ferrate tri-hydrate) was added and vortexed for approximately 1 min.

Subsequently, 20 µl of C₁ solution 2% ZnSO₄-7H₂O, (Zink sulphate hepta-hydrate) was added and stirred for about another minute. The samples thus prepared were subjected to another centrifugation cycle for 10 minutes at 12400 rpm.

The supernatant was collected using a syringe and filtered using HPLC filters directly into glass vials that were then sealed with a rubber septum cap (Figure 3.8).

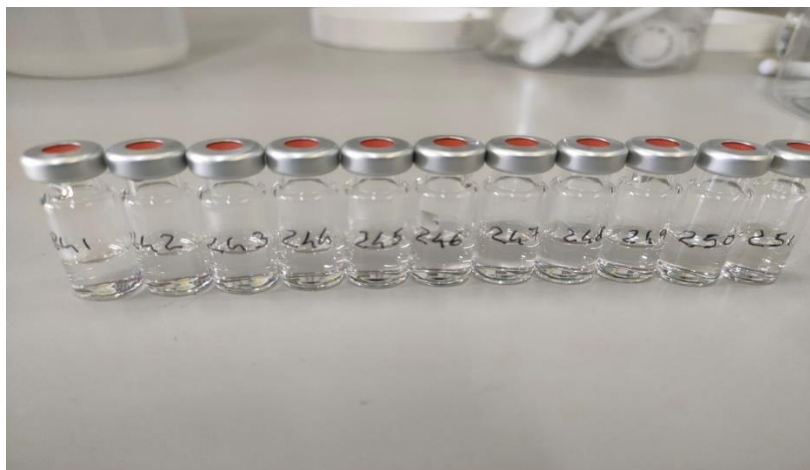

Figure 3.8 Samples ready for injection into HPLC for TVFA analysis.

Subsequently, the samples were injected and analysed using HPLC Agilent 1200 (Figure 3.9).



Figure 3.9 HPLC Agilent 1200.

The following standards were used as internal standards for the quantification of total fatty acids and are listed in order of retention time:

- 1) *citric acid* [$C_6H_8O_7$],
- 2) *gluconic acid* [$C_6H_{12}O_7$],
- 3) *lactic acid* [$C_3H_6O_3$],
- 4) *fumaric acid* [$C_4H_4O_4$],
- 5) *acetic acid* [CH_3COOH],
- 6) *propionic acid* [$C_3H_6O_2$],
- 7) *iso-butyric acid* [$(CH_3)_2CHCOOH$],
- 8) *butyric acid* [$C_4H_8O_2$],
- 9) *crotonic acid* [$C_4H_6O_2$],
- 10) *iso-valeric acid* [$C_5H_{10}O_2$],
- 11) *valeric acid* [$C_5H_{10}O_2$],
- 12) *capronic acid* [$C_6H_{12}O_2$].

The volatile fatty acids examined for the control of the anaerobic digestion process were six: acetic acid, propionic acid, iso-butyric acid, iso-valeric acid and valeric acid.

3.1.6 Determination of Total Polyphenols

Polyphenols are a very large family of organic molecules found in the plant kingdom that are associated with an antioxidant and antibacterial function. In fact, high quantities of these substances can inhibit the metabolism of the bacterial consortium and consequently also the anaerobic digestion process (Battista et al., 2014). For the quantification of total polyphenols, the Folin-Ciocalteu method was performed. Specifically, 100 μl of the sample to be analysed was taken after suitable dilution, to which 6000 μl of distilled water and 500 μl of Folin-Ciocalteu reagent were added, all of which was reacted for 8 minutes. Subsequently, 1500 μl of 20% Na_2CO_3 was taken and added to a volume (10 ml) by adding 1900 μl of distilled water. The samples were incubated in the dark for two hours and then read in the spectrophotometer (SHIMADZU UV-VIS 1800) at 750 nm.

The results are expressed as mg gallic acid g/L^{-1} .

3.2 Experimental set- up of the experiments

The BMP test or biochemical methane potential is a parameter expressing the amount of biogas/methane potentially obtainable from the degradation of a biomass. Static BMP analyses were conducted on a laboratory scale by simulating, in a controlled environment, what takes place in an anaerobic digester.

To avoid inhibiting effects, the amount of volatile solids (SV) of the matrix must not exceed the amount of volatile solids of the inoculum. Indeed, the ratio between the two values should be maintained below 0.5 (V. Verg, S. Substratcharakterisierung 2006).

Before conducting the BMP tests, it is necessary to characterise the substrates and inoculum considering physical and chemical properties, in accordance with the *VDI 4630*, in order to adequately set-up the matrix content in the reactor, address the suitable process parameters, and avoid inhibiting effects (V. Verg, S. Substratcharakterisierung 2006).

Hence, the mixtures (food substrate + inoculum) were prepared as shown in Table 2. and put into laboratory reactors using half-filled 1000 ml DURAN® GL 45 bottles (Figure 3.10).



Figure 3.10 Weighing of samples directly into the reactors and addition of inoculum.

Before being sealed, the reactors were insufflated with nitrogen gas, and hermetically connected to another bottle containing 3M sodium hydroxide solution to absorb CO_2 . This latter was connected via a siphon system to a bottle containing water for measuring the volume of bio-methane (Figure 3.11). The reactors were incubated in a climatic chamber at 37°C to promote mesophilic conditions with a residence time of at least 30 days (Figure 3.12). The tests were conducted considering three replicates for each thesis. The volume of water displaced by the fermenting biomass, comparable to the amount of bio-methane, was measured daily.

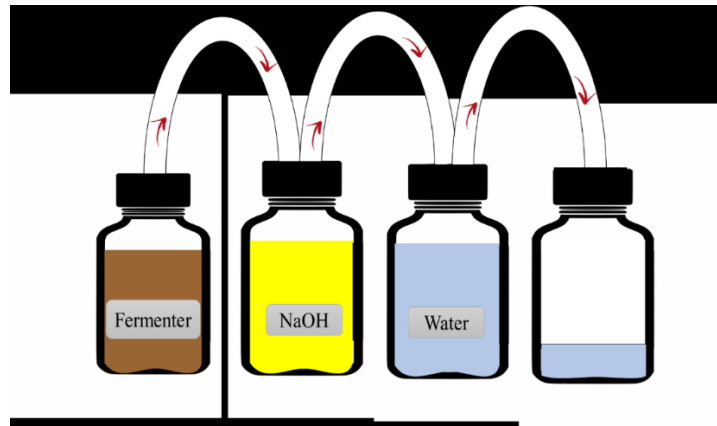

Figure 3.11 Setting up the reactors



Figure 3.12 Climate cell set at a temperature of 37 °C to favour the mesophilic environment.

The biogas volumes obtained were normalized to standard temperature and pressure conditions ($T = 0\text{ }^{\circ}\text{C}$ and $P = 1013\text{ hPa}$) as indicated in the procedures described in VDI 4630 (2006).

$$V_0^{tr} = V \cdot \frac{(p - p_w) \cdot T_0}{p_0 \cdot T}$$

Where:

V_0^{tr} : volume of dry gas in normal state, in ml_n

V: volume of gas read, in ml

p: pressure of the gaseous phase at the time of reading, in hPa

p_w : vapor pressure of water as a function of ambient temperature, in hPa

T_0 : normal temperature; $T_0 = 273\text{ }^{\circ}\text{K}$

p_0 : normal pressure = 1013 hPa

T temperature of the fermentation gas or of the ambient space, in $^{\circ}\text{K}$.

3.3 Continuous test set up

While in the fourth experiment, two CSTR reactors fed daily were used.

Both reactors were filled with the same amount of inoculum (6l) and fed daily with mixture composed of 80%curds and 20%expired sausages, with increasing doses. This was necessary because the inoculum was not suitable for digesting this type of substrate. It was necessary to acclimatise the inoculum by starting with minimal doses of substrate. At time T₀, the reactors were fed with only 6 g of substrate, every three days the dose was increased by a factor of two until reaching 140 g of substrate on the last days of experimentation with a variable OLR (organic load rate).

Every day, at the same time, the pH, temperature and gas composition parameters were measured before feeding the reactors. Finally, at each feed change (approximately every three days), an aliquot of the mass being digested, approximately 50 ml, was taken for chemical-physical characterisation, evaluating all the reactor management parameters. Particularly, pH was measured using a pH probe (XS PH 8+ DHS laboratory pH meter), total solids TS (%) were determined at 105 °C using a moisture analyzer (Ohaus, MB120), total volatile solids TVS (% of the dry content) were determined after ignition at 550 °C with a muffle furnace (Heraeus, M110) (Hulsemann B. et al. 2020). Chemical oxygen demand (COD) (g.L⁻¹) was measured following the COD measurement method for high concentration samples. Total kjeldahl nitrogen (TKN) and ammonium contents, were quantified using an auto-distiller (B.U.C.H.I, Autokjeldahl unit k370). Total volatile fatty acids VFA were quantified using high performance liquid chromatography HPLC. The trial was conducted for 48 days with an OLR (Organic Load Rate) variable from 0.31 [gTVS /liter/day] (T1) to 0.77 [gTVS /liter/day] (T42).

The reactors were built using appropriate materials to maintain an anoxic and pressure-tight environment. The reactor, shown in Figure 1, consists of a digestion chamber, a stirring system and a system for qualitative and quantitative measurement of the methane produced. The reaction chamber is constructed of stainless steel (SS) plates enclosing a tempered glass cylinder which forms the core of the reactor. The stirring system is located at the top of the cylinder.

It consists of a three-phase electric motor block connected to a gear motor to reduce the speed of the electric motor. In addition, a temperature probe and a biogas outlet are integrated, as indicated by Bernardi et al., (2017). The amount of gas produced is measured with a gas meter (Ritter TG 0.5 drum gas meter) and collected and stored in a gas bag connected downstream. Finally, the gas bag is connected to an Awite process analyser (AwiFLEX Cool+) for the qualification of the biogas produced. Ritter drum gas meters (wet test) are suitable for measuring the volume of gas in circulation with the highest accuracy.

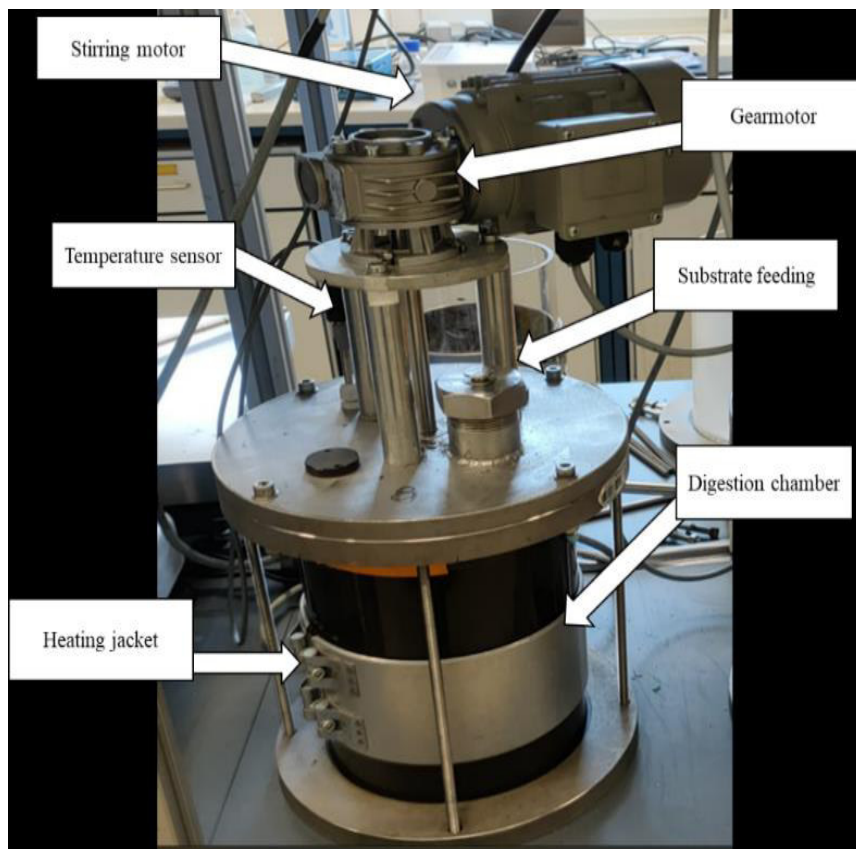

Figure 3.13 Reactor set-up

3.4 Statistical analysis

Analysis of variance was applied to the data to determine significant differences between the result means. It was conducted to check Biomethane produced during the trial period using different experimental design. To identify differences between the groups, when significant differences were observed, Tukey test was performed post-analysis, with a significance level of $p < 0.05$. Free R software Version 4.0.4 (R Foundation for Statistical Computing Platform) was used for data processing.

ACKNOWLEDGEMENT

Neri, A., Bernardi, B., Zimbalatti, G., & Benalia, S. (2023). An Overview of Anaerobic Digestion of Agricultural By-Products and Food Waste for Biomethane Production. *Energies*, 16(19). <https://doi.org/10.3390/en16196851>

REFERENCES

Abouelenien, Fatma, Yuzaburo Namba, Maria R. Kosseva, Naomichi Nishio, and Yutaka Nakashimada. 2014. "Enhancement of Methane Production from Co-Digestion of Chicken Manure with Agricultural Wastes." *Bioresource Technology* 159:80–87. doi:10.1016/j.biortech.2014.02.050.

Acea energia: Potere calorifico inferiore e potere calorifico superiore: differenze. <https://www.acea.it/guide/potere-calorifico-metano> (22/10/2023).

Adani, Fabrizio, Andrea Schievano, and Giuliana D'Imporzano. 2008. "I Fattori Che Rendono Ottimale La Razione per Il Digestore." *L'Informatore Agrario* 40.

Alam, M., Sultan, M.B, Mehnaz, M., Fahim, C.S.U., Hossain, S., Anik, A.H. 2022. Production of biogas from food waste in laboratory scale dry anaerobic digester under mesophilic condition. 2022 *Energy Nexus* Volume 7, September 2022, 100126. doi.org/10.1016/j.nexus.2022.100126

APHA (1998) *Standard Methods for the Examination of Water and Wastewater*. American Public Health Association, Washington DC, USA.

ARERA 2020, Autorità di Regolazione per Energia Reti e Ambiente. Reti di trasporto e distribuzione del gas naturale: progetti pilota di ottimizzazione della gestione e utilizzi innovativi Linee di intervento (pag. 52-53)

Atelge, M. R., A. E. Atabani, J. Rajesh Banu, David Krisa, M. Kaya, Cigdem Eskicioglu, Gopalakrishnan Kumar, Changsoo Lee, Y. Ş. Yildiz, S. Unalan, R. Mohanasundaram, and F. Duman. 2020. "A Critical Review of Pretreatment Technologies to Enhance Anaerobic Digestion and Energy Recovery." *Fuel* 270(February):117494. doi: 10.1016/j.fuel.2020.117494.

Bailón Allegue, L. e J. Hinge (2012). *Biogas and Bio-Syngas Upgrading*. Danish Technological Institute Report. December 2012.

Balsari, P., 2009. Il biogas, un modo per sfruttare gli scarti, produrre energia e gestire il territorio. Workshop "L'agricoltura è energia a tutto campo", Torino Esposizioni, Sala Montreal, 8 ottobre.

Balsari, P., Menardo S., Gioelli, F., Dinuccio, E., 2009. European project EU-agro biogas: Aims, objectives and first results obtained. In: *Proceedings of the IX National Congress of the Italian Association of Agricultural Engineering - Research and innovation in engineering of agri-territorial bio systems*, Ischia Porto (Naples), 12-16 September 2009.

Balsari, P., Menardo, S., Gioelli, F., 2011. Tecniche di valorizzazione del contenuto energetico delle biomasse. In "Biomasse ed energia. Produzione, gestione e processi di trasformazione" (a cura di Silvana Castelli), Maggioli Editore, pp.133-157.

Battista, F., Fino, D., Ruggeri, B., 2014. Polyphenols Concentration's Effect on the Biogas Production by Wastes Derived from Olive Oil Production. *CHEMICAL ENGINEERING TRANSACTIONS* VOL. 38, 2014. DOI: 10.3303/CET1438063

Beltramo, T.; Klocke, M.; Hitzmann, B. Prediction of the biogas production using GA and ACO input features selection method for ANN model. *Sci. Total Environ.* 2019, 6, 349–356. doi.org/10.1016/j.inpa.2019.01.002

Benalia, S.; Falcone, G.; Stillitano, T.; De Luca, A.I.; Strano, A.; Gulisano, G.; Zimbalatti, G.; Bernardi, B. Increasing the content of olive mill wastewater in biogas reactors for a sustainable recovery: Methane productivity and life cycle analyses of the process. *Foods* 2021, 10, 1029. doi.org/10.3390/foods10051029

Beniche, I.; Hungría, J.; El Bari, H.; Siles, J.A.; Chica, A.F.; Martín, M.A. Effects of C/N ratio on anaerobic co-digestion of cabbage, cauliflower, and restaurant food waste. *Biomass Convers. Biorefinery* 2021, 11, 2133–2145. DOI: 10.1007/s13399-020-00733-x

Bernardi, B.; Benalia, S.; Zema, D.; Tamburino, V.; Zimbalatti, G. An automated medium scale prototype for anaerobic co-digestion of olive mill wastewater. *Inf. Process. Agric.* 2017, 4, 316–320. doi.org/10.1016/j.inpa.2017.06.004

Braun, Rudolf, P. Weiland, and A. Wellinger. 2010. “Biogas from Energy Crop Digestion.” IEA Bioenergy, Energy from Biogas and Landfill Gas Task 37 Br:12.

Bucchi G. 2015. “Studio di modelli matematici per la verifica e la progettazione di impianti di digestione anaerobica su scala di laboratorio e industriale”. Tesi Dottorato di ricerca in Scienze biochimiche e biotecnologie, Alma Mater Studiorum – Università degli studi di Bologna 2015.

Canziani, R.; Caputo, P.; Carrosio, G.; Chiesa, D.; Ficara, E.; Ghelardi, G. P.; Insabato, G.; Malpei, F. et al. 2012 “Energia da biogas. Manuale per la progettazione e gestione degli impianti”, Edizioni Ambiente 2012.

Castelli, S., 2011. Ruolo delle biomasse e filiere energetiche. In “Biomasse ed energia. Produzione, gestione e processi di trasformazione” (a cura di Silvana Castelli), Maggioli Editore, pp.21-32.

Castelli, S., Negri, M., 2011. La digestione anaerobica: processo e parametri di controllo. In “Biomasse ed energia. Produzione, gestione e processi di trasformazione” (a cura di Silvana Castelli), Maggioli Editore, pp. 163-181.

Cecchi, F., P. Battistoni, P. Pavan, D. Bolzanella, and L. Innocenti. 2005. “Digestione Anaerobica Della Frazione Organica Dei Rifiuti Solidi.” 178.

Cecchi, F.; Battistoni, P.; Pavan, P.; Bolzanella, D.; Innocenti, L. Digestione Anaerobica Della Frazione Organica dei Rifiuti Solidi; APAT: Rome, Italy, 2005

Cedex, Villeurbanne. 1987. “Effects of Propionic Acid Concentration on Anaerobic Digestion of Pig Manure.” 13:1–12.

Chaurasia, A.K.; Siwach, P.; Shankar, R.; Mondal, P. Effect of pre-treatment on mesophilic anaerobic co-digestion of fruit, food and vegetable waste. *Clean Technol. Environ. Policy* 2021, 25, 603–616. doi.org/10.1007/s10098-021-02218-5

Chen, Ye, Jay J. Cheng, and Kurt S. Creamer. 2008. “Inhibition of Anaerobic Digestion Process: A Review.” *Bioresource Technology* 99(10):4044–64. doi: 10.1016/j.biortech.2007.01.057.

Colonna, N., Alfano, V., Gaeta, M., 2009. La stima del potenziale da biogas da biomasse di scarto del settore zootecnico in Italia. ENEA, Report RSE/2009/201.

Corbellini, V., Insabato, G., Malpei, F., & Corbellini, V. (2015). *Biometano. La Fabbrica della Bioenergia*. Politecnico di Milano.

Cruz, I.A.; de Melo, L.; Leite, A.N.; Sátiro, J.V.M.; Andrade, L.R.S.; Torres, N.H.; Padilla, R.Y.C.; Bharagava, R.N.; Tavares, R.F.; Ferreira, L.F.R. A new approach using an open-source low cost system for monitoring and controlling biogas production from dairy wastewater. *J. Clean. Prod.* 2019, 241, 118284. doi.org/10.1016/j.jclepro.2019.118284

CTI, 2007. Comitato Termotecnico Italiano, Energia e Ambiente. APPARECCHI PER LA CONVERSIONE ENERGETICA DI BIOGAS, “Relazione tecnica sviluppata nell’ambito del progetto INTERREG IIIA BIOGAS CH-I? (www.cti2000.it)

Dahunsi, S. O. 2019. “Mechanical Pretreatment of Lignocelluloses for Enhanced Biogas Production: Methane Yield Prediction from Biomass Structural Components.” *Bioresource Technology* 280:18–26. doi: 10.1016/j.biortech.2019.02.006.

De Feo, Giovanni, Sabino De Gisi, Maurizio Galasso, and Dario Flaccovio. 2013. “Fanghi Di Depurazione Produzione, Caratterizzazione e Trattamento.” Dario Flaccovio Editore.

de Zorzi, Paolo, Stefania Balzamo, Sabrina Barbizzi, Elisa Calabretta, Monica Rosamilia, and Silvia Potalivo. 2014. Procedura Di Misurazione per La Determinazione Della Richiesta Chimica Di Ossigeno (COD) Mediante Test in Cuvetta: Metodo 5135. ISPRA.

Decreto 18 dicembre 2008. Incentivazione della produzione di energia elettrica da fonti rinnovabili, ai sensi dell'articolo 2, comma 150, della legge 24 dicembre 2007, n. 244.

Decreto 23 giugno 2016. Incentivazione dell’energia elettrica prodotta da fonti rinnovabili diverse dal fotovoltaico.

Decreto Legge 30 dicembre 2018, n. 145. Bilancio di previsione dello Stato per l'anno finanziario 2019 e bilancio pluriennale per il triennio 2019-2021.

Decreto legislativo 13 gennaio 2003, n. 36 “Attuazione della direttiva 1999/31/CE relativa alle discariche di rifiuti”.

Decreto legislativo 3 aprile 2006, n. 152 Norme in materia ambientale.

Decreto legislativo 8 novembre 2021, n. 199. Attuazione della direttiva (UE) 2018/2001 del Parlamento europeo e del Consiglio, dell'11 dicembre 2018, sulla promozione dell'uso dell'energia da fonti rinnovabili.

Decreto ministeriale 6 luglio 2012 ed allegati - Incentivi per energia da fonti rinnovabili elettriche non fotovoltaiche.

Decreto-legge 1 marzo 2022, n. 17. Misure urgenti per il contenimento dei costi dell'energia elettrica e del gas naturale, per lo sviluppo delle energie rinnovabili e per il rilancio delle politiche industriali.

Decreto-legge 21 marzo 2022, n. 2. Misure urgenti per contrastare gli effetti economici e umanitari della crisi ucraina.

Delgenès, J.P., Penaud, V., Torrijos, M., and R. Moletta. 2000. Investigations on the changes in anaerobic biodegradability and biotoxicity of an industrial microbial biomass. *Water Science and Technology* Vol 41 No 3 pp 137–144© IWA Publishing 2000 1.

Directive 2009/29/ec of the european parliament and of the council of 23 April 2009 amending Directive 2003/87/EC so as to improve and extend the greenhouse gas emission allowance trading scheme of the Community.

Direttiva (UE) 2018/851 del Parlamento europeo e del Consiglio, del 30 maggio 2018, che modifica la direttiva 2008/98/CE relativa ai rifiuti (Testo rilevante ai fini del SEE).

Distefano, T.D., Ambulkar, A., 2006. Methane production and solids destruction in an anaerobic solid waste reactor due to post- reactor caustic and heat treatment. *Water Sci. Technol.* 53, 33–41. DOI: 10.2166/wst.2006.233

Drosg, B. 2013. Process Monitoring in Biogas Plants. Technical Brochure. 2013. IEA Bioenergy.

Drosg, B., Fuchs, W., Teodorita Al Seadi, T., Madsen, M., Linke, B., 2015 Nutrient Recovery by Biogas Digestate Processing. Technical Brochure. 2015. IEA Bioenergy

Drosg, Bernhard, Werner Fuchs, Teodorita Al Seadi, Michael Madsen, and Bernd Linke. 2020. Nutrient Recovery by Biogas Digestate Processing. Technical Brochure. 2020. IEA Bioenergy

El Gnaoui, Y.; Karouach, F.; Bakraoui, M.; Barz, M.; El Bari, H. Mesophilic anaerobic digestion of food waste: Effect of thermal pretreatment on improvement of anaerobic digestion process. *Energy Rep.* 2020, 6, 417–422. <https://doi.org/10.1016/j.egy.2019.11.096>

Epa, U. S., and O. W. Office. 2001. “METHOD 1684 Total , Fixed , and Volatile Solids in Water , Solids , and Biosolids Draft January 2001 U . S . Environmental Protection Agency Office of Water Office of Science and Technology Engineering and Analysis Division (4303).” (January). Ertr, Maximale. n.d. “Bioextrusion ®.” 1–38.

Escalante, H., Castro, L., Amaya, M.P. Jaimes, L., Jaimes-Estévez, J. Anaerobic digestion of cheese whey: Energetic and nutritional potential for the dairy sector in developing countries. 2018. *Waste Management* Volume 71, January 2018, Pages 711-718. <https://doi.org/10.1016/j.wasman.2017.09.026>

Farhat, A.; Asses, N.; Ennouri, H.; Hamdi, M.; Bouallagui, H. Combined effects of thermal pretreat-ment and increasing organic loading by co-substrate addition for enhancing municipal sewage sludge anaerobic digestion and energy production. *Process Saf. Environ. Prot.* 2018, 119, 14–22. doi.org/10.1016/j.psep.2018.07.013

Farhat, A.; Manai, I.; Gtari, M.; Bouallagui, H. Effect of enhancing nutrient balance in anaerobic digester feedstock by co-substrate addition on the microbial diversity and energy production from municipal sewage sludge. *J. Biosci. Bioeng.* 2018, 126, 497–506. doi.org/10.1016/j.jbiosc.2018.04.014

Farnetti, A., Cozzolino, C., Bolzonella, D., Innocenti, L., Cecchi, C., 1999. Semi-dry anaerobic digestion of OFMSW: the new full-scale plant of Verona (Italy). In *II Int. Symp. Anaerobic Dig. Solid Waste, Barcelona, June 15-17, 1999* (eds. J. Mata-Alvarez, A. Tilche et F. Cecchi), vol. 2, pp.330-333, Int. Assoc. Wat. Qual.

Feiz, R., Johansson, M., Lindkvist, E., Moestedt, J., Pålédal, S. N., & Svensson, N. (2020). Key performance indicators for biogas production—methodological insights on the life-cycle analysis of biogas production from source-separated food waste. *Energy*, 200. doi.org/10.1016/j.energy.2020.117462

FNR. Leitfaden Biogas. Available online: <https://mediathek.fnr.de/leitfaden-biogas.html> (accessed on 18 August 2023).

Folino, A.; Calabrò, P.S.; Zema, D.A. Effects of ammonia stripping and other physico-chemical pretreatments on anaerobic digestion of swine wastewater. *Energies* 2020, 13, 3413. doi.org/10.3390/en13133413

Folino, Adele, Paolo Salvatore Calabrò, and Demetrio Antonio Zema. 2020. “Effects of Ammonia Stripping and Other Physico-Chemical Pretreatments on Anaerobic Digestion of Swine Wastewater.” *Energies* 13(13). doi: 10.3390/en13133413.

Fricke, K.; Santen, H.; Wallmann, R.; Hüttner, A.; Dichtl, N. Operating problems in anaerobic digestion plants resulting from nitrogen in MSW. *Waste Manag.* 2007, 27, 30–43. doi.org/10.1016/j.wasman.2006.03.003

Fricke, Klaus, Heike Santen, Rainer Wallmann, Axel Hüttner, and Norbert Dichtl. 2007. "Operating Problems in Anaerobic Digestion Plants Resulting from Nitrogen in MSW." *Waste Management* (New York, N.Y.) 27(1):30–43. doi: 10.1016/j.wasman.2006.03.003.

Garrote, G., Dominguez, H., Parajo, J.C., 1999. Hydrothermal processing of lignocellulosic materials. *Holz Roh Werkst.* 57 1919-202.

Gourdon, R., Vermande, P., 1987. Effects of propionic acid concentration on anaerobic digestion of pig manure. *Biomass* Volume 13, Issue 1, 1987, Pages 1-12. doi.org/10.1016/0144-4565(87)90067-9

Greco C. 2011. La produzione di biogas e digestato in Sicilia: Un modello di sviluppo ecosostenibile nella filiera agro-energetica. Tesi di Dottorato di ricerca *Tecnologie per la Sostenibilità ed il Risanamento Ambientale-* Università degli studi di Palermo 2011.

Hansen, K.H., Angelidaki, I. and Ahring, B.K. (1998) Anaerobic Digestion of Swine Manure: Inhibition by Ammonia. *Water Research*, 32, 5-12.

Helffrich, D. und H. Oechsner: Hohenheimer Biogasertragstest. *Agrartechnische Forschung* 9 (2003) 3, S. 27–30. (December):1–97. doi.org/10.1016/S0043-1354(97)00201-7

Jiang, J., Li, L., Mingchao Cui, M., Zhang, F., Liu, Y., Liu, Y., Long, J., Guo, Y. 2018. "Anaerobic Digestion of Kitchen Waste: The Effects of Source, Concentration, and Temperature." *Biochemical Engineering Journal* 135:91–97. doi: 10.1016/j.bej.2018.04.004.

Kafle, G.K.; Kim, S.H.; Sung, K.I. Ensiling of fish industry waste for biogas production: A lab scale evaluation of biochemical methane potential (BMP) and kinetics. *Bioresour. Technol.* 2013, 127, 326–336. doi.org/10.1016/j.biortech.2012.09.032

Kaltschmitt, M.; Hartmann, H.: *Energie aus Biomasse – Grundlagen, Techniken und Verfahren*; Springer Verlag; Berlin, Heidelberg, New York, 2001

Karim, Khursheed, Rebecca Hoffmann, K. Thomas Klasson, and M. H. Al-Dahhan. 2005. “Anaerobic Digestion of Animal Waste: Effect of Mode of Mixing.” *Water Research* 39(15):3597–3606. doi: 10.1016/j.watres.2005.06.019.

Kaspar, H.F., K. Wuhrmann, K. 1978. Kinetic parameters and relative turnovers of some important catabolic reactions in sludge digestion. *Appl Environ Microbiol.* 1978 luglio;36(1):1-7. doi: 10.1128/aem.36.1.1-7.1978.

Kazimierowicz, J.; Dzienis, L.; Debowski, M.; Zielinski, M. Optimisation of methane fermentation as a valorisation method for food waste products. *Biomass Bioenergy* 2021, 144, 105913.

Khalid, Azeem, Muhammad Arshad, Muzammil Anjum, Tariq Mahmood, and Lorna Dawson. 2011. “The Anaerobic Digestion of Solid Organic Waste.” *Waste Management (New York, N.Y.)* 31(8):1737–44. doi: 10.1016/j.wasman.2011.03.021.

KTBL-Arbeitspapier 249: Kofermentation. KTBL (Hrsg.), KTBL-Schriften-Vertrieb im Landwirtschaftsverlag Münster- Hiltrup 1998, ISBN 3-7843-1971-8.

Lebuhn, M.; Bauer, C.; Gronauer, A.: Probleme der Biogasproduktion aus nachwachsenden Rohstoffen im Langzeitbetrieb und molekularbiologische Analytik. *VDLUFA-Schriftenreihe* 64, 2008, pp. 118–125

Lee, E.; Bittencourt, P.; Casimir, L.; Jimenez, E.; Wang, M.; Zhang, Q.; Ergas, S.J. Biogas production from high solids anaerobic co-digestion of food waste, yard waste and waste activated sludge. *Waste Manag.* 2019, 95, 432–439.

Lehmann, 2011. Bio-extrusion, Lehmann Maschinenbau GmbH. URL <http://www.lehmann-maschinenbau.de/>. (available online: 03/12/2023).

Li, L.; Feng, L.; Zhang, R.; He, Y.; Wang, W.; Chen, C.; Liu, G. Anaerobic digestion performance of vinegar residue in continuously. *Bioresource Technology* Volume 186, June 2015, Pages 338-342. doi.org/10.1016/j.biortech.2015.03.086

Li, Y.; Jin, Y.; Li, H.; Borrion, A.; Yu, Z.; Li, J. Kinetic studies on organic degradation and its impacts on improving methane production during anaerobic digestion of food waste. *Appl. Energy* 2018, 213, 136–147.

Lin, J.; Zuo, J.; Gan, L.; Li, P.; Liu, F.; Wang, K.; Chen, L.; Gan, H. Effects of mixture ratio on anaerobic co-digestion with fruit and vegetable waste and food waste of China. *J. Environ. Sci.* 2011, 23, 1403–1408.

Lindorfer, H.; Braun, R.; Kirchmeyr, R.: The self-heating of anaerobic digesters using energy crops; *Water Science and Technology* 53 (8), 2006

Manso, T., Marta Lores and de Miguel, T. 2020. Antimicrobial Activity of Polyphenols and Natural Polyphenolic Extracts on Clinical Isolates. *Antibiotics* 2022, 11, 46. <https://doi.org/10.3390/antibiotics11010046>

Marchaim, Uri, and Carsten Krause. 1993. “Propionic to Acetic Acid Ratios in Overloaded Anaerobic Digestion.” *Bioresource Technology* 43(3):195–203. doi: 10.1016/0960-8524(93)90031-6.

Martínez-Hernández Carlos M., Oechsner Hans Brulé Mathieu. 2021. “Hohenheim Yield Test (HBT) Methodology for the Determination of Methane Potential in Agricultural Substrates.” *Revista Ciencias Técnicas Agropecuarias* 30(July):1–9.

Megido, L.; Negral, L.; Fernández-Nava, Y.; Suárez-Peña, B.; Ormaechea, P.; Díaz-Caneja, P.; Castrillón, L.; Marañón, E. Impact of organic loading rate and reactor design on thermophilic anaerobic digestion of mixed supermarket waste. *Waste Manag.* 2021, 123, 52–59.

Meng, Y.; Li, S.; Yuan, H.; Zou, D.; Liu, Y.; Zhu, B.; Chufo, A.; Jaffar, M.; Li, X. Evaluating biomethane production from anaerobic mono- and co-digestion of food waste and floatable oil (FO) skimmed from food waste. *Bioresour. Technol.* 2015, 185, 7–13.

Mengon, Silvia 2017 “Dal biogas al biometano: simulazione di processo ed analisi tecno-economica delle principali tecnologie presenti nel mercato europeo”. Tesi di Laurea Magistrale in Ingegneria Chimica e dei Processi Industriali (unipd)

Montgomery, L. F. R. and Bochmann, G., 2014. Pretreatment of feedstock for enhanced biogas production. Technical Brochure. IEA Bioenergy 2014.

Oleszek, Marta, and Izabela Krzemi. 2021. “Biogas Production from High-Protein and Rigid Cell Wall Microalgal Biomasses : Ultrasonication and FT-IR Evaluation of Pretreatment Effects.” 296(March). doi: 10.1016/j.fuel.2021.120676.

Omar, R., R. M. Harun, T. I. Moh. Ghazi, W. A. K. G. Wan Azlina, A. Idris, and R. Yunus. 2008. “Anaerobic Treatment of Cattle Manure for Biogas Production.” *AIChE Annual Meeting, Conference Proceedings* 1–10.

Palatsi, J.; Viñas, M.; Guivernau, M.; Fernandez, B.; Flotats, X. Anaerobic digestion of slaughterhouse waste: Main process limitations and microbial community interactions. *Bioresour. Technol.* 2011, 102, 2219–2227.

Palmowski, L., Muller, J., 1999. Influence of the size reduction of organic waste on their anaerobic digestion. Proceedings of The Second International Symposium on anaerobic digestion of solid waste, Barcelona June 15-17; 137-144.

Panigrahi, Sagarika, and Brajesh K. Dubey. 2019. "A Critical Review on Operating Parameters and Strategies to Improve the Biogas Yield from Anaerobic Digestion of Organic Fraction of Municipal Solid Waste." *Renewable Energy* 143:779–97. doi: 10.1016/j.renene.2019.05.040.

Parawira W. Anaerobic treatment of agricultural residues and waste water application of high-rate reactors. Doctoral Dissertation. Sweden, Department of Biotechnology, Lund University; 2004.

Park, S.; Li, Y. Evaluation of methane production and macronutrient degradation in the anaerobic co-digestion of algae biomass residue and lipid waste. *Bioresour. Technol.* 2012, 111, 42–48.

Penaud, V., Delgenès, J., Moletta, R., 1999. Thermo-chemical pretreatment of a microbial biomass: influence of sodium hydroxide addition on solubilization and anaerobic biodegradability. *Enzyme and Microbial Technology* 25, 258–263.

Perin, J.K.H., Biesdorf Borth, P.L., Torrecilhas, A.R., da Cunha, L.S. b, Kuroda, E.K., a, Fernandes, F. 2020. Optimization of methane production parameters during anaerobic co-digestion of food waste and garden waste. *Journal of Cleaner Production* Volume 272, 1 November 2020, 123130. doi.org/10.1016/j.jclepro.2020.123130

Pramanik, S.K.; Suja, F.B.; Zain, S.M.; Pramanik, B.K. The anaerobic digestion process of biogas production from food waste: Prospects and constraints. *Bioresour. Technol. Rep.* 2019, 8, 100310.

Qiao, Zihao, Suyun Xu, Wanqiu Zhang, Shuyin Shi, Wei Zhang, and Hongbo Liu. 2022. "Potassium Ferrate Pretreatment Promotes Short Chain Fatty Acids Yield and Antibiotics Reduction in Acidogenic Fermentation of Sewage Sludge." *Journal of Environmental Sciences (China)* 120:41–52. doi: 10.1016/j.jes.2022.01.001.

Rattanapan, C.; Sinchai, L.; Suksaroj, T.T.; Kantachote, D.; Ounsaneha, W. Biogas production by co-digestion of canteen food waste and domestic wastewater under organic loading rate and temperature optimization. *Environments* 2019, 6, 16.

Regolamento (CE) n. 1069/2009 DEL PARLAMENTO EUROPEO E DEL CONSIGLIO del 21 ottobre 2009 recante norme sanitarie relative ai sottoprodotti di origine animale e ai prodotti derivati non destinati al consumo umano e che abroga il regolamento (CE) n. 1774/2002 (regolamento sui sottoprodotti di origine animale).

Regolamento (CE) N. 1774/2002 DEL PARLAMENTO EUROPEO E DEL CONSIGLIO del 3 ottobre 2002 Consiglio per quanto concerne le norme di trasformazione relative agli impianti di produzione di biogas e di compostaggio e i requisiti applicabili allo stallatico.

Regolamento (CE) N. 208/2006 DELLA COMMISSIONE del 7 febbraio 2006 che modifica gli allegati VI e VIII del regolamento (CE) n. 1774/2002 del Parlamento europeo e del Regolamento (CE) n. 208/2006 della Commissione, del 7 febbraio 2006, che modifica gli allegati VI e VIII del regolamento (CE) n. 1774/2002 del Parlamento europeo e del Consiglio per quanto concerne le norme di trasformazione relative agli impianti di produzione di biogas e di compostaggio e i requisiti applicabili allo stallatico.

Regolamento (UE) 1119/2021 DEL PARLAMENTO EUROPEO E DEL CONSIGLIO del 30 giugno 2021. che istituisce il quadro per il conseguimento della neutralità climatica e che modifica il regolamento (CE) n. 401/2009 e il regolamento (UE) 2018/1999 («Normativa europea sul clima»).

Rosato, M. A.; 2015, “Manuale per il gestore dell’impianto di biogas. Tecniche di laboratorio per monitorare il processo biologico in modo semplice ed efficace”. Editoriale Delfino 2015.

Rupc, Slavko, Davor Kralik, Daria Jovic, Robert Spajic, and Marina Tišma. 2020. “Pulsed Electric Field: An Emerging Pretreatment Technology in a Biogas Production ~ Ic.” (xxxx). doi: 10.1016/j.wasman.2020.10.009.

Salerno, Michael B., Hyung-sool Lee, Prathap Parameswaran, and Bruce E. Rittmann. 2008. “Using a Pulsed Electric Field as a Pretreatment for Improved Biosolids Digestion and Methanogenesis.” 2005–18.

Sanders, W.T.M., 1999. Anaerobic hydrolysis during digestion of complex substrates. ISBN: 90-5808-375-6.

Scarcello, L.; Benalia, S.; Zimbalatti, G.; Fazari, A.; Bernardi, B. A Smart Automation System for the Management and Control of a Medium Scale Digester Plant. In AIIA 2022: Biosystems Engineering Towards the Green Deal: Improving the Resilience of Agriculture, Forestry and Food Systems in the Post-Covid Era; Springer: Berlin/Heidelberg, Germany, 2023; pp. 917–925.

Scherer, P.A.: A miniaturized instrument to measure slow biogas flow rates. In: Proceedings of Anaerobic Digestion of Solid Wastes 2002, IWA World Congress, Technical University Munich.

Scherer, P.A.: Biogascounterstation für Co-Vergärungen. KA Wasserwirtschaft, Abwasser, Abfall 48 (2001), S. 245–246.

Schieder, D., Schneider, R., Bischof, F., 2000. Thermal hydrolysis (TDH) as a pretreatment method for the digestion of organic waste. Water Sci. Technol. 41, 181–187.

Schneider, T., Müller, D. and J. Karl, J. (2020). "A review of thermochemical biomass conversion combined with Stirling engines for the small-scale cogeneration of heat and power". *Renewable and Sustainable Energy Reviews* 134 (2020) 110288

Sebola., M., Tesfagiorgis, H. and Muzenda, E., 2015. Effect of particle size on anaerobic digestion of different feedstocks. *South African Journal of Chemical Engineering*, vol. 20, 2015, no. 3, pp. 11- 26. hdl.handle.net/10520/EJC189206

Shen, F.; Yuan, H.; Pang, Y.; Chen, S.; Zhu, B.; Zou, D.; Liu, Y.; Ma, J.; Yu, L.; Li, X. Performances of anaerobic co-digestion of fruit & vegetable waste (FVW) and food waste (FW): Single-phase vs. two-phase. *Bioresour. Technol.* 2013, 144, 80–85.

Speece, R., 1983. Anaerobic biotechnology for industrial wastewater treatment. *Environ Sci Technol.* 1983 Sep 1;17(9):416A-27A. doi: 10.1021/es00115a725.

Speece, Richard E. 1983. "FEATURES ES & T Anaerobic Biotechnology for Industrial Wastewater Treatment a Description of Several Installations."

Sun, Chen, Weixing Cao, Charles J. Banks, Sonia Heaven, and Ronghou Liu. 2016. "Biogas Production from Undiluted Chicken Manure and Maize Silage: A Study of Ammonia Inhibition in High Solids Anaerobic Digestion." *Bioresource Technology* 218:1215–23. doi: 10.1016/j.biortech.2016.07.082.

Sun, Y.; Dai, H.-L.; Moayed, H.; Le, B.N.; Adnan, R.M. Predicting steady-state biogas production from waste using advanced machine learning-metaheuristic approaches. *Fuel* 2023, 355, 129493.

Teixeira, R.A.; Bueno, B.A.; Borges, R.M.; Bringhenti, J.R. Biochemical Methane Potential of Spent Coffee Grounds via Co-digestion with FoodWaste. *BioEnergy Res.* 2021, 1–12.

Thompson, Ethan, Qingbin Wang, and Minghao Li. 2013. "Anaerobic Digester Systems (ADS) for Multiple Dairy Farms: A GIS Analysis for Optimal Site Selection." *Energy Policy* 61:114–24. doi: 10.1016/j.enpol.2013.06.035.

Tufaner, F. Evaluation of COD and color removals of effluents from UASB reactor treating olive oil mill wastewater by Fenton process. *Sep. Sci. Technol.* 2020, 55, 3455–3466.

UNI-ISO 11734:2004 Qualità dell'acqua - Valutazione della biodegradabilità anaerobica ultima di composti organici in fanghi digeriti - Metodo per misurazione della produzione di biogas.

UNI-ISO 38414:2008 Rivestimenti metallici e altri rivestimenti inorganici - Rivestimenti elettrolitici di oro e di leghe di oro per impieghi industriali, elettronici ed elettrotecnici - Specifiche e metodi di prova.

UNI-ISO 6976:2017 Gas naturale - Calcolo del potere calorifico, della densità, della densità relativa e dell'indice di Wobbe, partendo dalla composizione.

UNI-ISO/TS 11537:2019 Immissione di biometano nelle reti di trasporto e distribuzione di gas naturale.

V. Verg, S. Substratcharakterisierung, and V. D. Ingenieure. 2006. INGENIEURE.

Vavilin, V.A, Rytov, S.V. and Lokshina, L.Y., 1996. A description of hydrolysis kinetics in anaerobic degradation of particulate organic matter. *Bioresource Technology* Volume 56, Issues 2–3, May–June 1996, Pages 229-237

Vernon, O., L. Singleton, and M. Lamuela-Raventos. 1999. "Analysis of Total Phenols and Other Oxidation Substrates and Antioxidants by Means of Folin-Ciocalteu Reagent." *Scientia Horticulturae* 213(1974):281–86. doi: 10.1016/j.scienta.2016.11.004.

Vijayakumar, Pradeshwaran, Saravanakumar Ayyadurai, Kantha Deivi Arunachalam, Gaurav Mishra, Wei-Hsin Chen, Joon Ching Juan, and Salman Raza Naqvi. 2022. "Current Technologies of Biochemical Conversion of Food Waste into Biogas Production: A Review." *Fuel* 323(January):124321. doi: 10.1016/j.fuel.2022.124321.

Vismara, R., Canziani, R., Malpei, F., Piccinini, S., 2011. *Biogas da agro-zootecnia e agroindustria*. Dario Flaccovio Editore, pp. 57-59.

Vismara, R.; Malpei, F.; Centemero, M., 2008, "Biogas da rifiuti solidi urbani: tecnologia, applicazioni, utilizzo". Dario Flaccovio Editore 2008.

Visser, André. 1995. "The Anaerobic Treatment of Sulfate Containing Wastewater." 157.

Wang, S., Ma, F., Ma, W., Wang, P. Zhao, G., Lu, X, 2019 Influence of Temperature on Biogas Production Efficiency and Microbial Community in a Two-Phase Anaerobic Digestion System. *Enhancement of Anaerobic Digestion for Energy and Resource Recovery*), doi.org/10.3390/w11010133

WEILAND, P. (2008). Gärrestaufbereitung. 17. Symposium Bioenergie, 20.-21.11.2008, Kloster Banz, Bad Staffelstein, Germany.

Weiland, P.: Grundlagen der Methangärung – Biologie und Substrate; VDI-Berichte, No. 1620 'Biogas als regenerative Energie – Stand und Perspektiven'; pp. 19-32; VDI-Verlag 2001

Weinrich, S., F. Schäfer, G. Bochmann, and J. Liebetrau. 2018. *Value of Batch Tests for Biogas Potential Analysis*. Vol. 10.

Wellinger, A.; Baserga, U.; Edelmann, W.; Egger, K.; Seiler, B.: Biogas-Handbuch, Grundlagen – Planung – Betrieb landwirtschaftlicher Anlagen, Verlag Wirz – Aarau, 1991

Wendland, M., (2009). Biogasgärreste: Einsatz von Gärresten aus der Biogasproduktion als Düngemittel, Bayerische Landesanstalt für Landwirtschaft, Germany

Xiao, Benyi, Wenzhe Zhang, Hao Yi, Yu Qin, Jing Wu, Junxin Liu, and Yu You Li. 2019. “Biogas Production by Two-Stage Thermophilic Anaerobic Co-Digestion of Food Waste and Paper Waste: Effect of Paper Waste Ratio.” *Renewable Energy* 132:1301–9. doi: 10.1016/j.renene.2018.09.030.

Xu, F.; Li, Y. Solid-state co-digestion of expired dog food and corn stover for methane production. *Bioresour. Technol.* 2012, 118, 219–226.

Xu, Fuqing, Yangyang Li, Xumeng Ge, Liangcheng Yang, and Yebo Li. 2018. “Anaerobic Digestion of Food Waste – Challenges and Opportunities.” *Bioresource Technology* 247(September):1047–58. doi: 10.1016/j.biortech.2017.09.020.

Yong, Z.; Dong, Y.; Zhang, X.; Tan, T. Anaerobic co-digestion of food waste and straw for biogas production. *Renew. Energy* 2015, 78, 527–530.

Zema, D.A.; Fòlino, A.; Zappia, G.; Calabrò, P.S.; Tamburino, V.; Zimbone, S.M. Anaerobic digestion of orange peel in a semicontinuous pilot plant: An environmentally sound way of citrus waste management in agri-ecosystems. *Sci. Total Environ.* 2018, 630, 401–408.

Zema, D.A.; Zappia, G.; Benalia, S.; Zimbalatti, G.; Perri, E.; Urso, E.; Tamburino, V.; Bernardi, B. Limiting factors for anaerobic digestion of olive mill wastewater blends under mesophilic and thermophilic conditions. *J. Agric. Eng.* 2018, 49, 130–137.

Zerrouki, Souhaib, Rachida Rihani, Karima Lekikot, and Ibtissem Ramdhane. 2021. “Enhanced Biogas Production from Anaerobic Digestion of Wastewater from the Fruit Juice Industry by Sonolysis: Experiments and Modelling.” *Water Science and Technology* 84(3):644–55. doi: 10.2166/wst.2021.245.

Zhang, C.; Xiao, G.; Peng, L.; Su, H.; Tan, T. The anaerobic co-digestion of food waste and cattle manure. *Bioresour. Technol.* 2013, 129, 170–176.

Zhang, Ruihong, Hamed M. El-Mashad, Karl Hartman, Fengyu Wang, Guangqing Liu, Chris Choate, and Paul Gamble. 2007. “Characterization of Food Waste as Feedstock for Anaerobic Digestion.” *Bioresource Technology* 98(4):929–35. doi: 10.1016/j.biortech.2006.02.039.

Zhang, W.; Zhang, L.; Li, A. Anaerobic co-digestion of food waste with MSW incineration plant fresh leachate: Process performance and synergistic effects. *Chem. Eng. J.* 2015, 259, 795–805.

Zhong W., Z., Hu, Y., Wang, S., Wu, G., Zhan, X., 2023. A critical review on dry anaerobic digestion of organic waste: Characteristics, operational conditions, and improvement strategies. *Renewable and Sustainable Energy Reviews* Volume 176, April 2023, 113208. doi.org/10.1016/j.rser.2023.113208

4. EXPERIMENTAL DESIGN N. 1: Recovery of agrifood by-products and food waste for bio-methane production¹

Abstract

This research activity aims to assess the methanogenic potential of different types of agri-food by-products and food waste subjected to anaerobic digestion processes. Biomethane potential (BMP) tests were performed under mesophilic conditions at 37°C. Prior to each test, all substrates were characterised considering physicochemical parameters, in particular pH, total solids (TS), total volatile solids (TVS), polyphenol content (PPs), chemical oxygen demand (COD), volatile fatty acids (VFA), total Kjeldahl nitrogen (TKN) and ammonium (NH₄⁺-N). The biomethane produced was assessed daily using the water displacement methodology and its volume was normalised to standard temperature and pressure conditions (T = 0 °C and P = 1013 hPa). The highest methane yield of 2.68 ± 3.90 NL_{methane}·gTVS⁻¹ or 629.88 Nm³_{methane}/t[TVS] was obtained from the reactor containing 3% curd, in addition to the inoculum.

Keywords: anaerobic mono-digestion; biogas, BMP test, mesophilic conditions, sustainable energy.

¹Neri, A., Benalia, S., Zimbalatti, G., Gabauer, W., Mihajilovic, I., Ghassemi, K., Poschmaier-Kamarad, L., & Benardi, B. (2023). RECOVERY OF AGRIFOOD BY-PRODUCTS AND FOOD WASTE FOR BIOMETHANE PRODUCTION. 31st European Biomass Conference and Exhibition, 5-8 June 2023, Bologna, Italy RECOVERY, June, 5–8.

4.1 Introduction

The extraction and combustion of fossil fuels is continuously and irreversibly compromising the environment and accentuating global warming, which is mainly caused by the emission of carbon dioxide CO₂ and methane CH₄ (Atelge M.R. et al. 2020). This led scientific community and stakeholders to look for alternative sources for energy production, including the recovery of biomass for biogas and biomethane production through anaerobic digestion process.

Agrifood and livestock by-products and domestic organic waste, indeed, still contain a lot of convertible matter in energy, making it possible to use them as a substrate in anaerobic digestion process to produce power and heat in a more sustainable way (Bartholameuz E.M et al. 2023). Anaerobic Digestion (AD) is a biological process in which a pool of microorganisms transform complex organic substance into biogas in absence of oxygen (Thompson E. et al.2013). The produced biogas, mainly contains 50-75% of methane (CH₄), 25-50% of carbon dioxide (CO₂), water vapour (H₂O) and traces of oxygen (O₂), nitrogen (N₂) and hydrogen sulphide (H₂S) (Omar R. et al. 2008). In addition, the resulting digestate, is a stabilized, odourless and rich of nutrient matrix, and could be used for agronomic purpose as an organic fertilizer and soil conditioner (Kazimierowicz and Dzienis., 2021) (Jiang J. et al., 2018). Today, biogas is used for combined heat and power (CHP) production. Also, it can be purified and fed into natural gas networks, and used as fuel for vehicles, for domestic needs or in fuel cells (Vitez T. et al., 2020). Biogas and biomethane yields depend on a series of factors such as physical-chemical features of the used organic matrix in anaerobic digestion reactors, as well as process operating parameters and conditions. Several authors investigated the potential of agrifood by-products and food waste to produce biogas. Vitez et al. (2020) used vegetable food waste under mesophilic conditions and obtained 1.11 NL_{methane}·gTVS⁻¹ or 817 Nm³/t[TVS] of biogas with a methane concentration ranging between 59.93 and 65.75%. Beniche et al. (2021) used supermarket food waste as a matrix and produced under thermophilic conditions 0.678 NL_{methane}·gTVS⁻¹ or 937 Nm³/t[TVS] of biogas. While Benalia et al. (2021) tested mixtures containing 0% (control), 20% and 30% (v/v) olive mill wastewater. They obtained higher amounts of biogas 5.80 NL_{methane}·gVS⁻¹ or 802,2 Nm³/t[TVS] when

using a higher amount of olive mill wastewater (30%) (v/v) in batch reactors. In this context, the present research activity aims at investigating the potential of different kinds of agrifood by-products and food waste to produce biogas and biomethane under anaerobic digestion process, considering their physical-chemical features.

4.2 Materials and methods

Various agri-industrial by-products and food waste were selected for the BMP tests, taking into account their seasonality and availability. Table 4.1 shows the substrates used and their origin. Curd and cheese-whey were self-produced by acid curdling whole milk. In addition, a digestate consisting of a mixture of three different digestates from three different industrial digestion plants was used as inoculum and substrate buffer.

Table 4.1 Samples of agrifood by-products and food waste used in the trials.

Food waste category	Substrates	Provenance
Cereals and farinaceous food waste	Bakery products	Supermarket
	Cooked pasta	Laboratory kitchen
	Cooked rice	Laboratory kitchen
	Oatmeal	Plant-based beverage processing waste
Dairy industry by-products	Whey	Self-produced
	Non-edible curd	Self-produced
	Expired sausage	
	Expired mozzarella cheese	Supermarket
Fruit and vegetables waste	Ready to eat vegetables	Supermarket
	Household vegetables waste	Supermarket
Meat product waste	Expired sausage	Supermarket

4.3 Physical-chemical characterization of the substrates

Before conducting the BMP tests, as indicated in Chapter 3, all substrates including the inoculum, were characterized from physical and chemical point of view to adequately set the substrate content in the reactor, address the appropriate process parameters and avoid inhibiting effects. Particularly, pH was measured using a pH probe (XS pH 8+ DHS laboratory pH meter), total solids TS (%) were determined at 105 °C using a moisture analyzer (Ohaus, MB120), total volatile solids TVS (% of the dry content) were determined after ignition at 550 °C with a muffle furnace (Heraeus, M110) (Hulsemann B. et al., 2020). Chemical oxygen demand (COD) (g.L^{-1}) was measured following the COD measurement method for high concentration samples. In addition, total polyphenols content (PPs) was measured according to the Folin Ciocalteu method (Singleton V.L. et al., 1999). Total Kjeldahl nitrogen (TKN) and ammonium contents, were quantified using an auto-distiller (B.U.C.H.I, Autokjeldahl unit k370). Total volatile fatty acids VFA were quantified using high performance liquid chromatography HPLC.

4.4 Experimental set-up and BMP test

Biochemical methane potential (BMP) is a parameter expressing the amount of methane potentially obtainable from the degradation of a biomass. Static BMP analyses were conducted on a laboratory scale by simulating, in a controlled environment, what takes place in an anaerobic digester. Hence, the mixtures (food waste/by-product + inoculum) were prepared as shown in Fig. 1 and put into laboratory reactors using half-filled 1000 ml DURAN® GL 45 bottles. Before being sealed, the reactors were insufflated with nitrogen gas to guarantee anaerobic medium, and then, hermetically connected to another bottle containing 3M sodium hydroxide solution to absorb CO_2 . This latter was connected via a siphon system to a bottle containing water for measuring the volume of biomethane (Figure 4.1). The reactors were incubated in a climatic chamber at 37°C to guarantee mesophilic conditions with a retention time of at least 30 days (Figure 4.2). The tests were conducted considering three replicates for each thesis, for a total of 33 reactors.

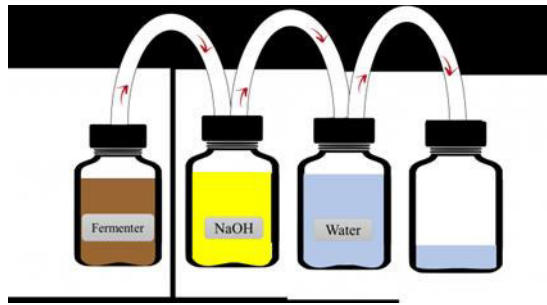

Figure 4.1 Graphical set-up of the BMP test with water displacement method for biomethane quantitation.



Figure 4.2 Reactors placed inside the climatic chamber at 37 °C.

The chemical-physical characterisation analyses were carried out both on the individual substrates prior to mixing with the inoculum, and on the anaerobically digested mixtures. Tables 4.2 and 4.3 show the results of the characterisation of each substrate. Next, the calculation of the percentage of substrate on the inoculum was carried out. To avoid inhibiting effects, the amount of total volatile solids (TVS) of the substrates must not exceed the amount of volatile solids of the inoculum. In fact, the ratio between the two values must be kept below 0.5 (V. Verg, S. Substratcharakterisierung, and V. D. 2006).

The analyses allowed the preparation of individual mixtures as show in Table 4.4.

Table 4.2 Physical-chemical characterization of the substrates subjected to BMP tests. Values expressed as mean of replicates \pm Dev. St.

	Unit	Inoculum (Control)	Bakery products	Cheese whey	Curd	Cooked rice	IV range vegetables
pH		7.92	5.15	5.43	5.83	7.23	5.93
TS	%	4.75 \pm 0.06	44.28 \pm 0.44	6.67 \pm 1.64	34.63 \pm 0.57	25.93 \pm 0.12	4.69 \pm 0.36
TVS on dry content	%	0.47 \pm 3.00	42.07 \pm 1.63	6.03 \pm 1.73	33.29 \pm 0.57	25.49 \pm 0,34	4.23 \pm 0.65
COD	g/kg	59.80 \pm 0.02	525.79 \pm 3.02	81.00 \pm 9.04	469.10 \pm 4.16	287.00 \pm 0.01	46.74 \pm 10.35
TKN	g/kg	3.40 \pm 0.48	7.24 \pm 6.01	0.58 \pm 4.37	21.11 \pm 0.37	3.25 \pm 0.53	1.03 \pm 3.34
NH ₄ ⁺ -N	g/kg	0.79 \pm 1.78	0.92 \pm 0.07	0.02 \pm 0.64	1.86 \pm 0.57	0.34 \pm 0.40	0.15 \pm 0.48
Total VFA	mg/l	250.03	5338.59	7877.68	1087.56	353.16	4319.92
Polyphenols	mg/kg	0.18 \pm 0.001	0.249 \pm 0.01	0.051 \pm 0.002	0.467 \pm 0.006	0.058 \pm 0.002	0.119 \pm 0.001

Table 4.3 Physical-chemical characterization of the substrates subjected to BMP tests. Values expressed as mean of replicates \pm Dev. St.

	Unit	Expired sausages	Fruits and vegetables mix	Cooked pasta	Mozzarella cheese	Spent oat
pH		5.94	4.92	6.31	567	-
TS	%	4261 \pm 0.34	10.58 \pm 4.23	42.80 \pm 0.33	58.67 \pm 3.12	34.04 \pm 3.83
TVS on dry content	%	38.76 \pm 1.96	9.72 \pm 4.63	40.40 \pm 0.77	54.49 \pm 2.97	33.88 \pm 3.81
COD	g/kg	532.41 \pm 4.72	131.24 \pm 1.88	481.94 \pm 0.41	618.06 \pm 7.81	494.27 \pm 0.95
TKN	g/kg	28.75 \pm 0.35	1.49 \pm 1.54	8.86 \pm 28.44	28.44 \pm 1.62	22.20 \pm 1.36
NH ₄ ⁺ -N	g/kg	2.09 \pm 0.89	0.23 \pm 0.2	1.08 \pm 0.21	2.87 \pm 0.23	2.40 \pm 0.25
Total VFA	mg/l	1334.75	5169.39	6267.26	1485.02	2067.44
Polyphenols	mg/kg	0.789 \pm 0.032	0.166 \pm 0.001	0.189 \pm 0.001	1.227 \pm 0.051	0.183 \pm 0.0001

Table 4.4 Experimental set-up adopted for anaerobic digestion trials.

	Thesis 1 (Control)	Thesis 2	Thesis 3	Thesis 4	Thesis 5	Thesis 6	Thesis 7	Thesis 8	Thesis 9	Thesis 10	Thesis 11
Inoculum	100%	98%	89%	97%	97%	85%	98%	93%	98%	98%	97%
Bakery products	-	2%	-	-	-	-	-	-	-	-	-
Cheese whey	-	-	11%	-	-	-	-	-	-	-	-
Curd	-	-	-	3%	-	-	-	-	-	-	-
Cooked rice	-	-	-	-	3%	-	-	-	-	-	-
IV range vegetables	-	-	-	-	-	15%	-	-	-	-	-
Expired sausages	-	-	-	-	-	-	2%	-	-	-	-
Fruits and vegetables mix	-	-	-	-	-	-	-	7%	-	-	-
Cooked pasta	-	-	-	-	-	-	-	-	2%	-	-
Mozzarella cheese	-	-	-	-	-	-	-	-	-	2%	-
Spent oat	-	-	-	-	-	-	-	-	-	-	3%

4.5 Results and discussion

Table 4.5 and 4.6 reports the results of physical-chemical characterization of the mixtures subjected to AD. We can observe that AD of all mixtures was performed in a wet medium, as total solid content is much below 10% (Cecchi et al. 2005). The pH of all mixtures appears to be optimal for starting anaerobic digestion. In fact, the measured pH was in line with the VDI 4630 guidelines, being between 6.98 ± 0.01 for the mixture containing 3% oatmeal and 7.71 ± 0.01 for that containing 2% cooked pasta. The pH provides an indication of the stability of the process, as its variation is associated with both of the buffering capacity of the system by the reaction medium, and the changes in the equilibrium between the species participating in the trophic chain of the involved microorganisms in the process. The measurement of this parameter can indicate whether there are unbalanced conditions in the system, but only with a certain delay in relation to the evolution of the buffering effect of the medium (Weinrich S. et al., 2018).

The VS content represents an approximation of the organic fraction of the substrate susceptible to be converted enabling therefore a preliminary estimation of the biogas to be produced (KTBL, 2015) (Drogs B. et al., 2013).

Chemical oxygen demand COD is also an important parameter as it enables to quantify the organic matter present in the samples and to have a rough estimate of biomethane production each gram of COD present in the sample will approximately give a 350 ml of CH_4 (V. Verg, S. Substratcharakterisierung, and V. D. 2006).

Volatile fatty acids fermentation produces acetic acid, hydrogen and carbon dioxide. The concentration level of volatile acids, generally expressed in terms of acetic acid or COD, depends on the type of substrate being treated, and varies from around 200 up to 2000 $\text{mgAc} \cdot \text{l}^{-1}$. Abrupt changes with an increase in concentration of VFA indicate that the process is slipping towards acidogenic rather than methanogenic processes. Generally speaking, it can be observed that an increase in volatile acids is a consequence of the increased load of the substrate to be treated, which determines the acceleration of hydrolytic and acidogenic phenomena with the consequent unbalancing of the trophic chain and the variation of the system towards low pH conditions, following the exhaustion of the buffering capacity of the medium (Hulsemann B. et al., 2020). Ammonium nitrogen ($\text{NH}_4^+\text{-N}$) is one of the

digestion products in anaerobic digestion. If nitrogen-rich feedstocks are used, inhibition by ammonia is often the reason for a process imbalance (KTBL 2015). Therefore, monitoring ($\text{NH}_4^+\text{-N}$) concentrations in the digester helps to estimate if ammonia inhibition is causing the process unbalance.

Table 4.5 Physical-chemical characterization of the mixtures (substrate+inoculum) subjected to BMP tests. Values expressed as mean of replicates \pm Dev. St.

	Unit	Inoculum (Thesis 1)	Thesis 2	Thesis 3	Thesis 4	Thesis 5
pH		7.92	7.06	7	7.58	7.03
TS	%	4.75 \pm 0.06	5.12 \pm 0.27	5.54 \pm 0.30	5.19 \pm 0.086	5.02 \pm 2.22
TVS on dry content	%	0.47 \pm 3.00	3.36 \pm 0.76	2.92 \pm 0.23	3.43 \pm 0.38	3.30 \pm 3.04
COD	g/kg	59.80 \pm 0.02	59.91 \pm 1.33	55.64 \pm 1.67	71.16 \pm 9.41	6167 \pm 2.25
TKN	g/kg	3.40 \pm 0.48	3.05 \pm 0.2	2.70 \pm 0.03	4.57 \pm 0.31	2.99 \pm 1.06
$\text{NH}_4^+\text{-N}$	g/kg	0.79 \pm 1.78	0.86 \pm 2.43	0.77 \pm 2.87	1.27 \pm 0.95	0.82 \pm 0.88
Total VFA	mg/l	250.03	729.75	317.09	339.77	115.36
Polyphenols	mg/kg	0.18 \pm 0.001	0.149 \pm 0.004	0.108 \pm 0.004	0.217 \pm 0.004	0.189 \pm 0.004

Table 4.6 Physical-chemical characterization of the mixtures (substrate+inoculum) subjected to BMP tests. Values expressed as mean of replicates \pm Dev. St.

	Unit	Thesis 6	Thesis 7	Thesis 8	Thesis 9	Thesis 10	Thesis 11
pH		7.41	7.1	7.71	7.24	6.98	7.62
TS	%	4.35 \pm 1.97	5.47 \pm 2.29	4.90 \pm 0.08	5.10 \pm 0.08	5.23 \pm 0.13	4.95 \pm 0.59
TVS on dry content	%	2.82 \pm 1.8	3.67 \pm 3.61	3.19 \pm 0.14	3.33 \pm 0.06	3.44 \pm 0.99	3.28 \pm 0.47
COD	g/kg	49.15 \pm 3.85	65.69 \pm 4.86	62.09 \pm 0.63	56.74 \pm 11.33	66.05 \pm 4.88	65.159 \pm 2.16
TKN	g/kg	2.51 \pm 1.42	3.73 \pm 0.85	2.87 \pm 0.78	3.08 \pm 0.56	3.37 \pm 0.89	2.83 \pm 0.19
NH ₄ ⁺ -N	g/kg	0.86 \pm 0.68	1.18 \pm 1.49	0.88 \pm 0.68	0.88 \pm 1.12	1.20 \pm 1.41	1.34 \pm 0.74
Total VFA	mg/l	503.98	446.00	891.29	917.05	254.72	459.28
Polyphenols	mg/kg	0.148 \pm 0.006	0.195 \pm 0.004	0.150 \pm 0.001	0.151 \pm 0.007	0.141 \pm 0.012	0.180 \pm 0.001

The obtained biomethane volumes (Table 4.7) were normalised at standard temperature and pressure conditions ($T = 0\text{ }^{\circ}\text{C}$ and $P = 1013\text{ hPa}$) according to the procedures described in VDI 4630. For this experiment, which consisted of 11 theses (considering three replicates for each theses) for a total of 33 reactors and was carried out over a period of four weeks (29 days), an analysis of variance was carried out to check whether there were differences in CH_4 production for the weeks and hypotheses considered.

Table 4.7 CH_4 yield expressed as NL and average methane percentages produced by each theses. Values expressed as mean of replicates \pm Dev. St.

Theses	V(CH_4) NL/gTVS ⁻¹	CH_4 %
Thesis 1 (Control)	0.29 \pm 82.57	69.1
Thesis 2	1.87 \pm 18.65	84.5
Thesis 3	1.90 \pm 4.29	83.5
Thesis 4	2.65 \pm 20.13	78.0
Thesis 5	1.91 \pm 16.58	82.9
Thesis 6	1.64 \pm 2.59	87.0
Thesis 7	2.68 \pm 3.90	74.7
Thesis 8	1.75 \pm 4.68	85.0
Thesis 9	1.53 \pm 19.56	84.1
Thesis 10	2.12 \pm 12.16	74.6
Thesis 11	2.13 \pm 7.20	83.1

The Anova test conducted for CH_4 yield produced was significant at both week [$F(3,10) = 210.078$, $p < 0,05$ and theses [$F(3, 10) = 5.023$, $p < 0,05$]. Figure 4.3 shows that during the first week of operation (A), all the reactors in this experiment produced large quantities of biomethane; whereas from the second week onwards, there is an increasing reduction (B), until the third and fourth weeks, where production collapsed dramatically (C). In Figure 4.4 it can be seen that, in terms of

average normalised methane production, control A (thesis 1= inoculum), as expected, had the lowest bio-methane production. The theses T9-T6-T8 belonging to group B had the same production trend, the same applies to theses T2-T3-T5-T10 and T11 belonging to group BC. The only theses that were more productive in absolute terms were the theses T4 (97% inoculum + 3% curd) and T7 (98% inoculum + 2% expired sausages) both belonging to group C.

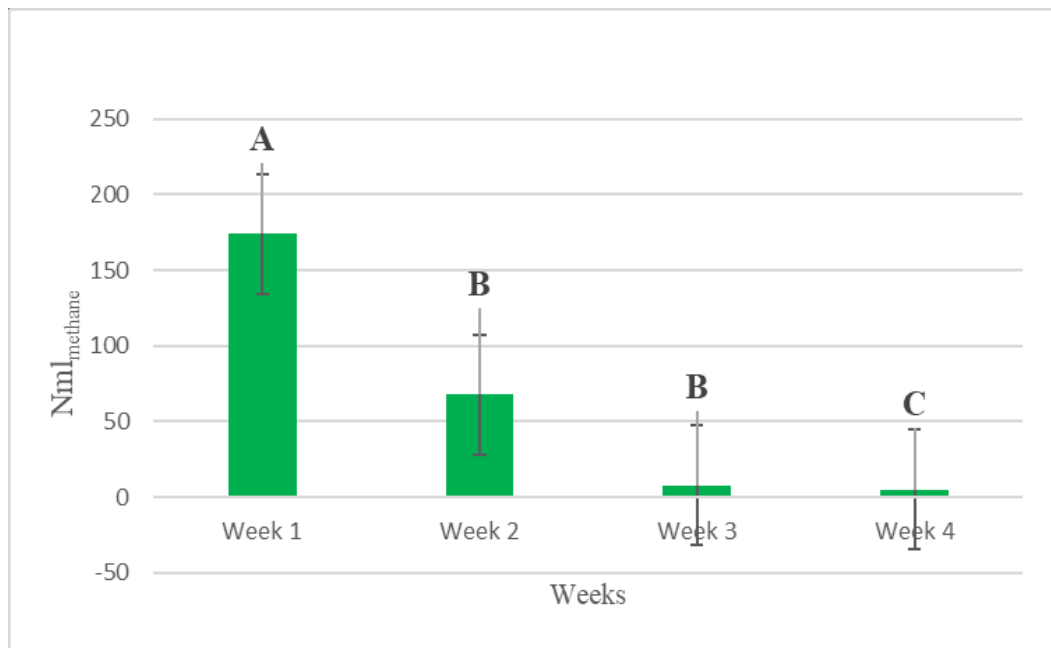

Figure 4.3 Production of $NL_{methane} \cdot gTVS^{-1}$ for the trial weeks. Data marked with different capital letters are significantly different by Tukey's test ($p < 0.05$).

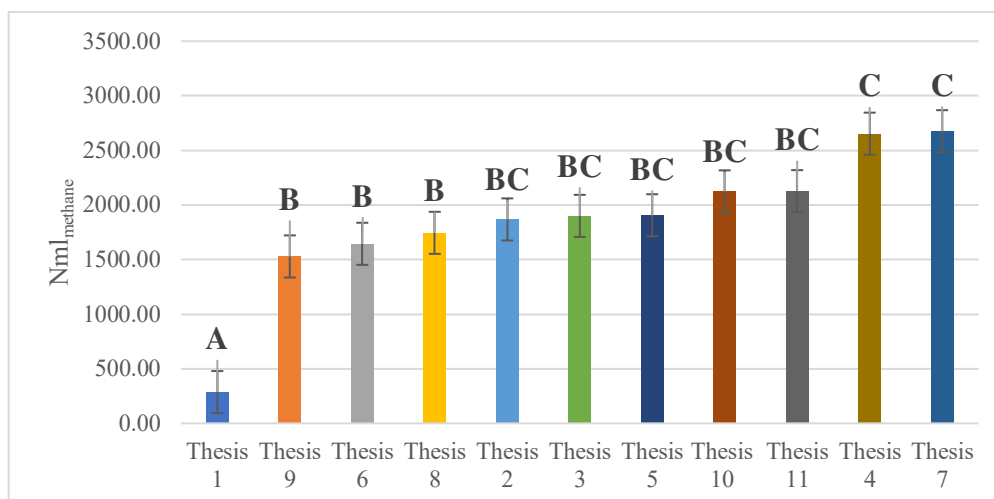

Figure 4.4 The graph shows that the most productive theses were 7 and 4 (C), with a production of $2675.99 \pm 3.90 \text{ Nm}^3_{\text{methane}}$ and $2653.08 \pm 20.13 \text{ Nm}^3_{\text{methane}}$ respectively. The least productive theses were 9-6-8 (B). While the others had an intermediate production (BC). Data marked with different capital letters are significantly different according to Tukey's test ($p < 0.05$).

As shown in Figures 4.4, 4.5 and 4.66, the highest methane yields, corresponding to $2.68 \pm 3.90 \text{ Nm}^3_{\text{methane}} \cdot \text{gTVS}^{-1}$ or $629.88 \text{ Nm}^3/\text{t}[\text{TVS}]$, were obtained from the reactor containing 2% expired sausage and $2.65 \pm 20.13 \text{ Nm}^3_{\text{methane}} \cdot \text{gTVS}^{-1}$ or $610.87 \text{ Nm}^3/\text{t}[\text{TVS}]$ composed of 3% curd. Over the inoculum, the lowest ($1.53 \pm 19.56 \text{ Nm}^3_{\text{methane}} \cdot \text{gTVS}^{-1}$ or $347.82 \text{ Nm}^3/\text{t}[\text{TVS}]$) was obtained from the reactor containing 2% expired mozzarella.

Other author, such as, Bella et. al. (2022), conducted a BMP test using cheese whey and had the highest methane production with 60% whey with a yield of $3.69 \pm 0.40 \text{ Nm}^3_{\text{methane}} \cdot \text{gTVS}^{-1}$ or $510 \text{ Nm}^3/\text{t}[\text{TVS}]$.

While in our case, a production of $4.64 \pm 1.90 \text{ Nm}^3_{\text{methane}} \cdot \text{gTVS}^{-1}$ or $441.08 \pm 3.73 \text{ Nm}^3_{\text{methane}}/\text{t}[\text{TVS}]$ of biomethane was obtained. The table 5 shows the $\text{Nm}^3_{\text{methane}} \cdot \text{gTVS}^{-1}$ yields and the percentage of methane produced.

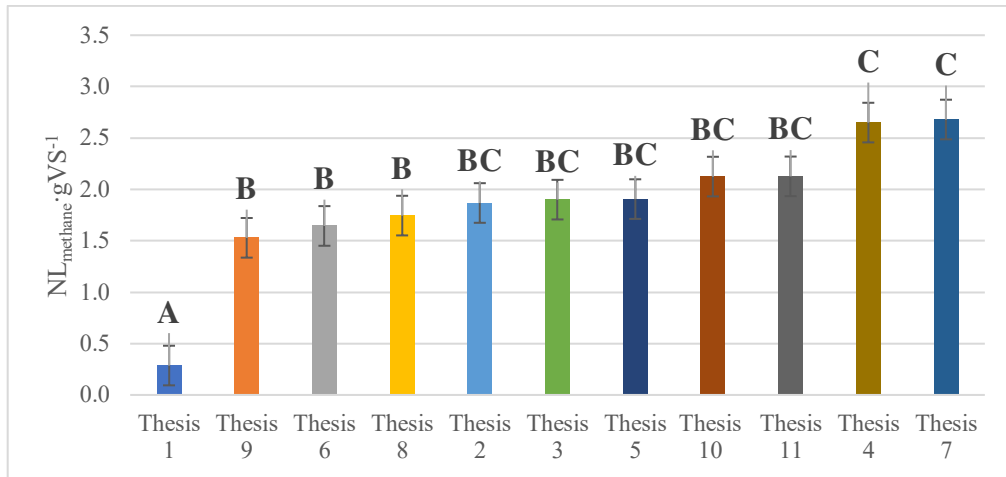

Figure 4.5. The graph shows that the most productive theses were 7 and 4 (C), with a production of $2.68 \pm 3.90 \text{ NL}_{\text{methane}} \cdot \text{gTVS}^{-1}$ and $2.68 \pm 3.90 \text{ NL}_{\text{methane}} \cdot \text{gTVS}^{-1}$ respectively. The least productive theses were 9-6-8 (B). While the others had an intermediate production (BC). Data marked with different capital letters are significantly different according to Tukey's test ($p < 0.05$).

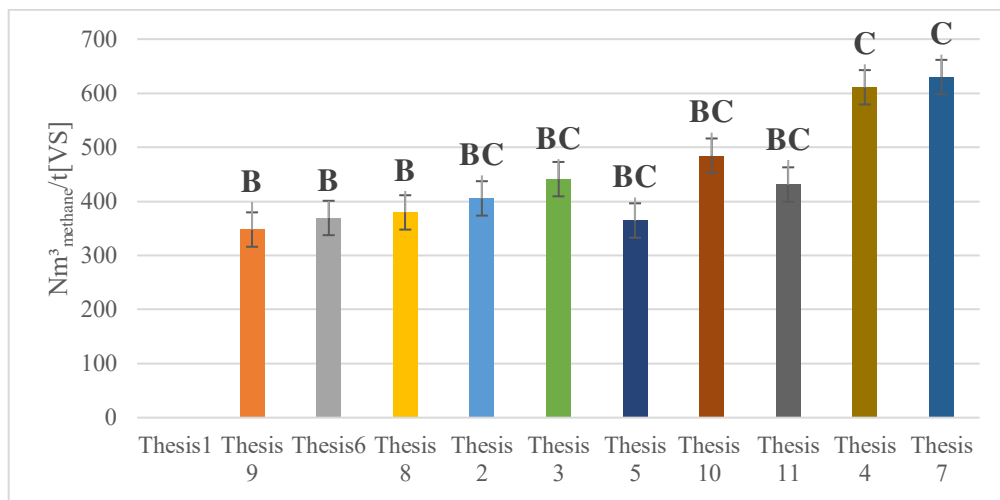

Figure. 4.6 The graph shows that the most productive theses were 7 and 4 (C), with a production of $629.88 \text{ Nm}^3/\text{t}[\text{TVS}]$ and $610.87 \text{ Nm}^3/\text{t}[\text{TVS}]$ respectively. The least productive theses were 9-6-8 (B). While the others had an intermediate production (BC). Data marked with different capital letters are significantly different according to Tukey's test ($p < 0.05$).

4.6 Treatment efficiency

Tables 4.8 and 4.9 show the characterisations of the mixtures (substrate+inoculum) subjected to anaerobic digestion.

Table 4.8 Results of the chemical-physical characterisation of the mixtures after undergoing anaerobic digestion. Values expressed as mean of replicates \pm Dev. St.

	Unit	Thesis 1 (Control)	Thesis 2	Thesis 3	Thesis 4	Thesis 5
pH		7.94 \pm 1.42	7.83 \pm 0.45	7.68 \pm 0.18	7.75 \pm 0.0001	7.80 \pm 0.0001
TS	%	4.83 \pm 0.16	4.87 \pm 0.5	4.31 \pm 0.21	4.93 \pm 2.23	4.72 \pm 1.72
TVS on dry content	%	3.01 \pm 0.29	3.04 \pm 0.56	2.63 \pm 0.39	3.09 \pm 1.99	2.95 \pm 2.63
COD	g/kg	54.85 \pm 4.77	61.34 \pm 3.46	48.14 \pm 14.76	55.68 \pm 4.40	46.95 \pm 33.70
TKN	g/kg	3.08 \pm 0.57	3.25 \pm 0.45	2.87 \pm 1.13	3.58 \pm 2.25	3.14 \pm 0.72
NH ₄ ⁺ -N	g/kg	1.14 \pm 0.57	1.25 \pm 2.38	1.12 \pm 14.71	1.57 \pm 1.87	1.26 \pm 10.43
Total VFA	mg/l	18.98 \pm 12.15	28.06 \pm 8.90	27.06 \pm 1.29	27.56 \pm 2.65	28.07 \pm 10.55
Polyphenols	mg/kg	0.15 \pm 14.59	0.14 \pm 2.30	0.14 \pm 1.09	0.14 \pm 1.98	0.13 \pm 10.77

Table 4.9 Results of the chemical-physical characterisation of the mixtures after undergoing anaerobic digestion. Values expressed as mean of replicates \pm Dev. St.

	Unit	Thesis 6	Thesis 7	Thesis 8	Thesis 9	Thesis 10	Thesis 11
pH		7.76 \pm 0.0001	7.8 \pm 0.0001	7.8 \pm 0.0001	7.77 \pm 1.18	7.82 \pm 0.27	7.61 \pm 0.27
TS	%	4.26 \pm 0.55	4.93 \pm 0.11	4.65 \pm 6.43	4.48 \pm 11.88	3.94 \pm 3.01	5.21 \pm 4.76
TVS on dry content	%	2.63 \pm 0.16	3.06 \pm 0.2	2.91 \pm 6.41	2.81 \pm 11.33	2.46 \pm 3.20	3.28 \pm 5.47
COD	g/kg	51.23 \pm 1.05	48.57 \pm 34.33	43.95 \pm 0.18	23.38 \pm 18.91	16.81 \pm 95.91	59.71 \pm 1.47
TKN	g/kg	3.00 \pm 5.76	3.74 \pm 2.82	3.12 \pm 6.34	3.10 \pm 5.25	2.66 \pm 12.78	2.81 \pm 48.94
NH ₄ ⁺ -N	g/kg	1.15 \pm 0.21	1.71 \pm 0.26	1.12 \pm 6.41	1.32 \pm 0.56	1.53 \pm 14.39	58.91 \pm 31.21
Total VFA	mg/l	24.49 \pm 0.2	27.95 \pm 6.64	23.54 \pm 20.84	21.32 \pm 16.56	20.60 \pm 0.08	29.15 \pm 2.66
Polyphenols	mg/kg	0.13 \pm 12.34	0.14 \pm 7.30	0.13 \pm 13.51	0.13 \pm 8.29	0.12 \pm 3.25	0.16 \pm 45.29

Even without buffer addition, the pH remained nearly neutral during the tests, with all treatments having non-statistically significant decreases in pH during digestion (Table 4.10).

Table 4.10 Initial pH and final pH of the theses

Theses	Initial pH	Final pH
Thesis 1 (Control)	7.92	7.94
Thesis 2	7.06	7.84
Thesis 3	7.00	7.68
Thesis 4	7.58	7.8
Thesis 5	7.41	7.76
Thesis 6	7.1	7.61
Thesis 7	7.71	7.82
Thesis 8	7.24	7.66
Thesis 9	6.98	7.77
Thesis 10	7.62	7.82
Thesis 11	7.92	7.71

In Table 4.11 shows the TVS abatement, between 9% and 47% of the initial VS was degraded during the 29-day test, with thesis 10 (2% mozzarella cheese + 98% inoculum) having the greatest reductions in TVS (47%) and thesis 6 (15% IV range vegetables + 85% inoculum) having the lowest reduction in TVS (9%).

Table 4.11 Percentage abatement of Volatile Solids. Results are expressed as percentage abatement of VS. Values expressed as mean of replicates \pm Dev. st

Theses	TVS pre-digestion (g/kg)	TVS post-digestion (g/kg)	Abatement %TVS
Thesis 1 (Control)	14.24 \pm 0.54	14.56 \pm 0.66	N.D
Thesis 2	17.20 \pm 1.04	14.72 \pm 1	14%
Thesis 3	13.24 \pm 0.54	11.28 \pm 2.11	15%
Thesis 4	17.83 \pm 0.47	15.36 \pm 3.51	14%
Thesis 5	16.56 \pm 5.27	14.06 \pm 3.59	15%
Thesis 6	12.28 \pm 3.78	11.14 \pm 11.8	9%
Thesis 7	20.11 \pm 5.9	15.10 \pm 0.16	25%
Thesis 8	15.66 \pm 0.22	13.91 \pm 1.13	11%
Thesis 9	17.02 \pm 0.03	13.07 \pm 1.98	23%
Thesis 10	17.99 \pm 1.12	9.61 \pm 3.37	47%
Thesis 11	16.34 \pm 2.96	14.56 \pm 1.84	N.D

While in Table 4.12 shows the COD abatement, As for the decrease in COD, between 14% and 57% of the initial COD was degraded during the 29-day test, with thesis 10 (98% inoculum + 2% mozzarella cheese) having the greatest COD reductions (57%) and thesis 4 (97% inoculum + 3% curd) having the lowest COD reduction (14%).

Table 4.12 Percentage abatement of COD. Results are expressed as percentage abatement of COD. Values expressed as mean of replicates \pm Dev. St.

Theses	COD pre-digestion (g/kg)	COD post-digestion (g/kg)	Abatement %COD
Thesis 1 (Control)	45.33 \pm 4.41	54.63 \pm 17.44	N.D
Thesis 2	59.92 \pm 1.34	64.21 \pm 9.77	N.D
Thesis 3	55.65 \pm 1.68	48.13 \pm 14.9	14%
Thesis 4	71.17 \pm 9.42	56.19 \pm 3.6	21%
Thesis 5	61.67 \pm 2.25	45.41 \pm 31.88	26%
Thesis 6	49.16 \pm 3.85	39.5 \pm 53.74	20%
Thesis 7	65.70 \pm 4.86	54.12 \pm 11.39	18%
Thesis 8	92.10 \pm 0.64	40.44 \pm 14.25	35%
Thesis 9	56.74 \pm 11.33	38.25 \pm 21.39	33%
Thesis 10	66.06 \pm 4.89	28.55 \pm 32.67	57%
Thesis 11	49.83 \pm 6.14	57.31 \pm 4	N.D

4.7 Conclusions

Findings achieved up to now are very promising confirming the reliability of anaerobic digestion process to recover energy from agrifood by-products and food waste, reducing significantly the emission of greenhouse gases into the atmosphere. This paper reports the intermediate results of an on-going research activity. The results of this first experiment were very satisfactory. In fact, in the second part of my work, mixtures of several substrates will be considered by testing them in a co-digestion process in order to assess their methanogenic potential. Furthermore, the continuous anaerobic digestion process with the tested substrates will be addressed in the last experimental part.

ACKNOWLEDGEMENT

This research is performed in the framework of PhD Course in Agricultural, Food and Forestry Science and Technology (XXXVI Cycle) of the University Mediterranea of Reggio Calabria and the Project “MEC – Marketplace Eco-sostenibile Calabria” (CUP B31B20000520005) financed under the Call for Proposals "Intelligent Factory, Agrifood and Life Sciences" of the Italian Ministry of Economic.

¹Neri, A., Benalia, S., Zimbalatti, G., Gabauer, W., Mihajilovic, I., Ghassemi, K., Poschmaier-Kamarad, L., & Bernardi, B. (2023). RECOVERY OF AGRIFOOD BY-PRODUCTS AND FOOD WASTE FOR BIOMETHANE PRODUCTION. 31st European Biomass Conference and Exhibition, 5-8 June 2023, Bologna, Italy RECOVERY, June, 5–8.

REFERENCES

Bartholameuz EM, Doluweera G, Gates ID. Biomass and MSW to Energy Technology Options for Distributed Electricity Generation in Canada. Lect Notes Civ Eng. 2023;249:183–95.

Bella K, Venkateswara Rao P. Anaerobic co- digestion of cheese whey and septage: Effect of substrate and inoculum on biogas production. J Environ Manage [Internet].2022;308(January):114581. doi.org/10.1016/j.jenvman.2022.114581

Benalia, S.; Falcone, G.;Stillitano, T.; De Luca, A.I.; Strano, A.; Gulisano, G.; Zimbalatti, G.; Bernardi, B. Increasing the Content of Olive Mill Wastewater in Biogas Reactors for a Sustainable Recovery: Methane Productivity and Life Cycle Analyses of the Process. Foods 2021. <https://doi.org/10.3390/foods10051029>.

Beniche I, Hungría J, El Bari H, Siles JA, Chica AF, Martín MA. Effects of C/N ratio on anaerobic co-digestion of cabbage, cauliflower, and restaurant food waste. Biomass Convers Biorefinery. 2021;11(5):2133–45.

Cecchi, F.; Battistoni, P.; Pavan, P.; Bolzanella, D.; Innocenti, L. *Digestione Anaerobica Della Frazione Organica dei Rifiuti Solidi*; APAT: Rome, Italy, 2005

Drosg B. Process monitoring in biogas plants Technical Brochure [Internet]. 2013. https://www.uibk.ac.at/umwelttechnik/teaching/phd/diss_schoen_2009_numerical-modelling-of-biogas-plants.pdf

Hülsemann B, Zhou L, Merkle W, Hassa J, Müller J, Oechsner H. Biomethane potential test: Influence of inoculum and the digestion system. *Appl Sci.* 2020;10(7).

Jiang J, Li L, Cui M, Zhang F, Liu Y, Liu Y, et al. Anaerobic digestion of kitchen waste: The effects of source, concentration, and temperature. *Biochem Eng J.* 2018;135:91–7. Available from: <https://doi.org/10.1016/j.bej.2018.04.004>

Kazimierowicz J, Dzienis L. Biomass and Bioenergy Optimisation of methane fermentation as a valorisation method for food waste products. 2021;144.

KTBL. Gasausbeute in landwirtschaftlichen Biogasanlagen. *KTBL H 107.* 2015;36.

M.R. Atelge, A.E. Atabani, J. Rajesh Banu, David Krisa, M. Kaya, Cigdem Eskicioglu, Gopalakrishnan Kumar, Changsoo Lee, Y.Ş. Yildiz, S. Unalan, R. Mohanasundaram, F. Duman, A critical review of pretreatment technologies to enhance anaerobic digestion and energy recovery, *Fuel*, Volume 270, 2020, 117494 <https://doi.org/10.1016/j.fuel.2020.117494>.

Omar R, Harun RM, Ghazi TIM, Wan Azlina WAKG, Idris A, Yunus R. Anaerobic treatment of cattle manure for biogas production. *AICHE Annu Meet Conf Proc.* 2008;1–10.

Singleton, V.L.; Orthofer, R.; Lamuela-Raventós, R.M. Analysis of total phenols and other oxidation substrates and antioxidants by means of folin-ciocalteu reagent. *Methods Enzymol.* 1999, 299, 152–178

Thompson E, Wang Q, Li M. Anaerobic digester systems (ADS) for multiple dairy farms : A GIS analysis for optimal site selection. *Energy Policy.* 2013;61:114–24. Available from: <http://dx.doi.org/10.1016/j.enpol.2013.06.035>

VDI 4630. Fermentation of Organic Materials. Characterisation of the Substrate, Sampling, Collection of Material Data, Fermentation Tests; VDI, Gesellschaft: Düsseldorf, Germany, 2006.

Vitez T, Dokulilova T, Vitezova M, Elbl J, Kintl A, Kynicky J, et al. The Digestion of Waste from Vegetables and Maize Processing. *Waste and Biomass Valorization* [Internet]. 2020;11(6):2467–73. Available from: <http://dx.doi.org/10.1007/s12649-019-00583-3>

Weinrich S, Schäfer F, Bochmann G, Liebetrau J. Value of batch tests for biogas potential analysis. Vol. 10, *IEA Bioenergy.* 2018. 37 p.

5. EXPERIMENTAL DESIGN N.2: Anaerobic co-digestion of mixtures composed of two agri-industrial by-products.

Abstract

The research activity was designed on the basis of the results of the previous experiment. The BMP test was performed on mixtures consisting of the most productive substrates, in terms of bio-methane production, identified in the previous experiment. The tests were carried out under mesophilic conditions (37°C). Prior to each test, the chemical-physical characterisation of the mixtures was conducted, taking into account all the start-up and operating parameters of the reactors. The ratio of substrate to inoculum was kept below ≤ 0.5 . Each day, the biomethane produced was evaluated using the water displacement methodology and measured against standard temperature and pressure conditions (T=0°C and P=1013 hPa). The highest methane yield, corresponding to 2.94 $\text{Nm}^3_{\text{methane}} \cdot \text{gTVS}^{-1}$ or 582.92 $\text{Nm}^3/\text{t}[\text{TVS}]$, was obtained from the reactor containing a mixture of 80% of curd and 20% of expired sausages.

Keywords: anaerobic co-digestion; bio-methane, BMP test, mesophilic conditions, sustainable energy.

5.1 Introduction

In the previous experiment, a study was carried out on anaerobic mono-digestion, i.e. the use of a single substrate which, when mixed with inoculum and subjected to an anaerobic regime, produces biogas. In this second phase, mixtures containing the most productive theses in terms of biomethane produced from the previous experiment were tested. In this phase, mixtures containing two substrates (80% curd+20% other substrate) were tested. This experiment was designed to test the co-digestion of several substrates, since heterogeneous mixtures are used in real digestion plants. For this reason, the co-digestion of agri-industrial and food waste was experimented. Several authors have investigated the potential of agri-food by-products and food waste for biogas production. Meng et al., (2015) tested the effect of different concentrations of FO waste (5, 20, 30, 40 and 50 g/l) on the biomethane produced using batches containing mixtures of floating oil (FO) extracted from food (FW). FO and FO + FW were mono-digested and co-digested. The results showed

that FO and FO + FW could be effectively anaerobically converted to biomethane using appropriate loads. However, anaerobic digestion appeared to be unstable when the FO concentration was 50 g/l. Maximum FO loads of 40 g/l and 30 g/l were therefore suggested for efficient mono-digestions and co-digestions of FO and FO + FW. Kazimierowicz et al., 2021 conducted a study on a laboratory scale using food waste products under mesophilic (37 °C) and thermophilic (55 °C) conditions. The maximum biogas yield was obtained in the mesophilic digestion of the substrate mixture containing 50% meat, 40% dairy and 10% fruit and vegetables. It was 0,740 NLCH₄/gTVS biogas with 68.6 ± 1.8% methane. Tixeira et al., (2021) used domestic waste coffee grounds (DSCGs) that came from the infusion of coffee and industrial waste coffee grounds (ISCGs) co-digested with food waste (FW). The reactors were fed with SCGs in the proportions of 0%, 25%, 50%, 75% and 100% dry weight, using a substrate/inoculum ratio of 1. BMP tests were performed for 45 days at mesophilic temperatures (35 ± 2°C). BMP levels were highest with 25% DSCG (0.345 Nm³ CH₄/kgTVS), 25% ISCG (0.351 Nm³CH₄/kgTVS) and 75% DSCG (0.301 Nm³ CH₄/kgTVS) samples. Zala et al., (2020) tested anaerobic digestion of food waste as a mono-digestion substrate and co-digestion of food waste with water hyacinth were tested and analysed in a batch-type anaerobic digester. Four different samples, i.e. only food waste, only water hyacinth and with food waste and water hyacinth in the ratio of 15:2 and 8:3 to keep the total solid content the same in all samples, were analysed for anaerobic digestion (AD). The biogas yield for the above four samples was 370.85 (ml/g TVS), 320.54 (ml/g TVS), 286.50 (ml/g TVS) and 298.83 (ml/g TVS) respectively. The average methane content was 68.3%, 58.2%, 52.1% and 65.4% respectively.

5.2 Materials and methods

As mentioned above, the experimental set-up was the same as in the previous experiment. Before preparing and filling the reactors, the mixtures were subjected to a chemical-physical characterization, and only after calculating the most appropriate ratio between substrate and inoculum could the experiment begin.

Curd was chosen as the basis for the production of the mixtures because it produced the highest amount of biomethane from a chemical-physical and biomethane productivity point of view $2.65 \text{ Nl}_{\text{methane}} \cdot \text{gTVS}^{-1}$ or $610.87 \text{ Nm}^3/\text{t}[\text{TVS}]$. The inedible curd represented the largest quantity in the mixtures (80%), while for the remaining 20% it was decided opted for another type of substrate of animal and vegetable origin. The preparation and setup of the reactors will be discussed in detail later.

5.3 Physical-chemical characterization of the substrates

The mixtures chosen in this part of the experiment are schematically represented in Table 5.1. Each mixture was prepared on 500 g final. Each percentage of substrate was weighed and then homogenised using a domestic mixer (Blendec, Vaso Wildside Flow).

Table 5.1 Experimental set-up of substrate mixtures

	Thesis 13	Thesis 14	Thesis 15	Thesis 16
Curd	80%	80%	80%	80%
Cheese whey	20%	-	-	-
Cooked rice	-	20%	-	-
Expired sausages	-	-	20%	-
Cooked pasta	-	-	-	20%

Exactly as in the last experiment and, as reported in the Materials and methods Chapter 3, before conducting all BMP tests, all mixtures, including the inoculum, were characterized from a chemical-physical point of view to correctly set the

substrate content in the reactor, identify appropriate process parameters and avoid inhibitory effects. Specifically, pH was measured with a pH probe (XS PH 8+ DHS laboratory pH meter), total solids TS (%) were determined at 105 °C with a moisture analyser (Ohaus, MB120), total volatile solids TVS (% on dry content) were determined after ignition at 550 °C with a muffle furnace (Heraeus, M110) (Epa, U.S., and O.W. Office, 2001). The chemical oxygen demand (COD) (g.L-1) was measured following the COD measurement method for high concentration samples. In addition, the content of total polyphenols (PPs) was measured according to the Folin Ciocalteu method (Singleton V.L. et al., 1999). Total Kjeldahl Nitrogen (TKN) and ammonium contents were quantified using an auto-distiller (B.U.C.H.I, Autokjeldahl unit k370). Total volatile fatty acids VFA were quantified by HPLC high-performance liquid chromatography.

5.4 Experimental set-up and BMP test

Static BMP analyses, on the substrate mixtures, were conducted at two different times. In a first step, mixtures containing two substrates were tested, and only in a second step were mixtures containing three substrates tested. The tests, again, were conducted on a laboratory scale simulating, in a controlled environment, what takes place in an anaerobic digester. Exactly as mentioned above, the mixtures (%substrates+%inoculum) were prepared as illustrated in Fig. 5.1 and placed in laboratory reactors using half-filled 1000 ml DURAN® GL 45 bottles. Before being sealed, the reactors were insufflated with nitrogen gas (N₂) to ensure an anaerobic medium and then hermetically connected to another bottle containing a 3M sodium hydroxide solution to absorb CO₂. The latter was connected via a siphon system to a bottle containing water to measure the volume of biomethane (Fig. 5.1).

The reactors were incubated in a climatic chamber at 37°C to ensure mesophilic conditions with a retention time of at least 45 days (Figure 5.2). The tests were conducted considering three replicates for each thesis, for a total of 15 reactors.

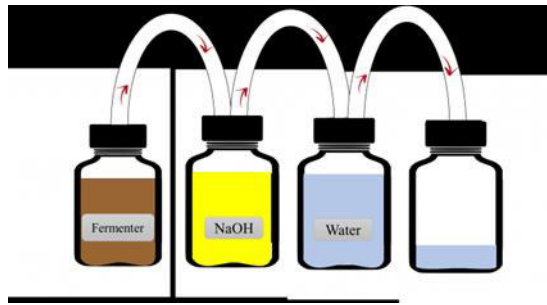

Figure 5.1 Graphical set-up of the BMP test with water displacement method for biomethane quantitation.



Figure 5.2 Reactors placed inside the climatic chamber at 37 °C

The chemical-physical characterisation analyses were carried out both on the mixtures of the different substrates, before mixing with the inoculum, and on the mixtures subjected to anaerobic digestion. Table 5.2 shows the results of the characterisation of each substrate. Subsequently, the calculation of the percentage of substrate on the inoculum was carried out. To avoid inhibiting effects, the amount of total volatile solids (TVS) of the substrate must not exceed the amount of volatile solids of the inoculum. In fact, the ratio between the two values must be kept below 0.5 (V. Verg, S. Substratcharakterisierung, and V. D. 2006). The analyses resulted in the preparation of the individual mixtures, as shown in Table 5.3.

Table 5.2 Physical-chemical characterization of substrates mixtures subjected to BMP tests. Values expressed as mean of replicates \pm Dev. St.

	Unit	Inoculum	80%curd + 20%cheese whey	80%curd + 20%cooked rice	80%curd + 20%expired sausages	80%curd + 20%cooked pasta
pH		7.88	5.62	5.64	5.54	5.74
TS	%	4.35 \pm 8.66	14.55 \pm 0.20	16.58 \pm 0.18	20.59 \pm 1.13	19.71 \pm 0.09
TVS on dry content	%	2.89 \pm 13.28	13.56 \pm 0.28	15.79 \pm 0.29	19.23 \pm 0.92	18.85 \pm 0.24
COD	g/kg	209.69 \pm 4.69	183.11 \pm 4.53	192.38 \pm 5.21	237.98 \pm 6.28	209.69 \pm 4.69
TKN	g/kg	3.16 \pm 0.38	12.50 \pm 0.28	11.86 \pm 0.61	16.85 \pm 2.19	13.27 \pm 0.49
NH ₄ ⁺ -N	g/kg	1.45 \pm 0.30	1.36 \pm 0.57	1.32 \pm 0.02	1.54 \pm 0.10	1.56 \pm 0.20
Total VFA	mg/l	219.05	12816.545	20747.835	10950.905	18670.855
Polyphenols	mg/kg	0.18 \pm 0.001	2.36 \pm 0.068	2.52 \pm 0.232	3.99 \pm 0.321	2.45 \pm 0.027

Table 5.3 Experimental set-up and reactors content.

	Thesis 12 (Control)	Thesis 13	Thesis 14	Thesis 15	Thesis 16
Inoculum	100%	94%	95%	95%	95%
80%curd + 20%cheese whey	-	6%	-	-	-
80%curd + 20%cooked rice	-	-	5%	-	-
80%curd + 20%expired sausages	-	-	-	5%	-
80%curd+20%cooked pasta	-	-	-	-	5%

5.5 Results and discussion

Table 5.4 shows the results of the physical-chemical characterisation of the mixtures subjected to AD. It can be observed that the AD of all mixtures was performed in a wet medium, as the total solids content was well below 10% (Cecchi et al., 2005). The pH of all mixtures was in line with the limit values between 6.5 and 8 (Lebuhn et al., 2008).

The pH of the mixtures, which underwent anaerobic digestion, ranged between 8.13 ± 0.01 for the thesis 15 containing 5% of the mixture consisting of 80% curds and 20% expired sausages, and 8.73 ± 0.01 for thesis 15 containing the mixture consisting of 80% paste and 20% cooked pasta. The pH measurement provided an indication of the stability of the process, in fact no anomalies were recorded during the entire digestion phase (Cecchi et al., 2005).

Table 5.4 Physical-chemical characterization of the mixtures (substrate+inoculum) subjected to BMP tests. Values expressed as mean of replicates \pm Dev. St.

	Unit	Thesis 12 (Control)	Thesis 13	Thesis 14	Thesis 15	Thesis 16
pH		7.88	8.73	8.14	8.13	8.09
TS	%	4.35 \pm 8.66	4.55 \pm 0.57	4.68 \pm 3.42	4.81 \pm 0.17	4.64 \pm 8.37
TVS on dry content	%	2.89 \pm 13.28	2.99 \pm 2.35	3.06 \pm 0.08	3.28 \pm 0.27	3.06 \pm 9.40
COD	g/kg	40.55 \pm 2.01	36.72 \pm 3.83	30.91 \pm 3.51	51.39 \pm 3.19	44.84 \pm 0.78
TKN	g/kg	3.16 \pm 0.38	3.30 \pm 0.80	3.39 \pm 1.95	3.43 \pm 1.81	3.34 \pm 0.22
NH ₄ ⁺ -N	g/kg	1.45 \pm 0.30	1.17 \pm 0.78	1.28 \pm 0.25	1.16 \pm 0.19	1.13 \pm 0.65
Total VFA	mg/l	219.05	248.5	226.9	271.9	224.5
Polyphenols	mg/kg	0.18 \pm 0.001	1.03 \pm 0.036	0.99 \pm 0.02	1.06 \pm 0.037	1.08 \pm 0.014

The obtained biomethane volumes (Table 5.5) were normalised at standard temperature and pressure conditions ($T = 0\text{ }^{\circ}\text{C}$ and $P = 1013\text{ hPa}$) according to the procedures described in VDI 4630. For this experiment, which consisted of 5 theses (considering three replicates for each theses) for a total of 15 reactors and was carried out over a period of six weeks (42 days), an analysis of variance was carried out to check whether there were differences in CH₄ production for the weeks and hypotheses considered.

Table 5.5 Cumulative methane yield and percentage of CH₄. Results are expressed as mean ± DV.ST

Theses	N _{methane} ·gTVS ⁻¹	CH ₄ %
Thesis 12 (Control)	0.08±7.42	80.7
Thesis 13	1.99±2.32	88.0
Thesis 14	1.59±28.09	90.8
Thesis 15	2.94±3.15	85.1
Thesis 16	2.14±9.69	86.3

This experiment, compared to the previous one, lasted six weeks.

The ANOVA test conducted for CH₄ yield produced was significant at both week [F(6,4)] = 102,34, p < ,005 and theses [F(6, 4)]= 2,01, p < 0,005.

Figure 5.3 show that during the first week of operation (A), all the reactors in this experiment produced large quantities of biomethane; whereas from the second week onwards, there is an increasing reduction (B), until the third and seventh weeks, where production collapsed dramatically (C).

In Figure 5.4 it can be seen that, in terms of mean normalised methane production, control A (thesis 1= inoculum), as expected, had the lowest bio-methane production. The T14-T13 and T16 theses belonging to group B had the same production trend. Whereas the most productive thesis, in terms of bio-methane, of this trial was the thesis T15 (consisting of 80% curd + 20% expired sausage) belonging to group C.

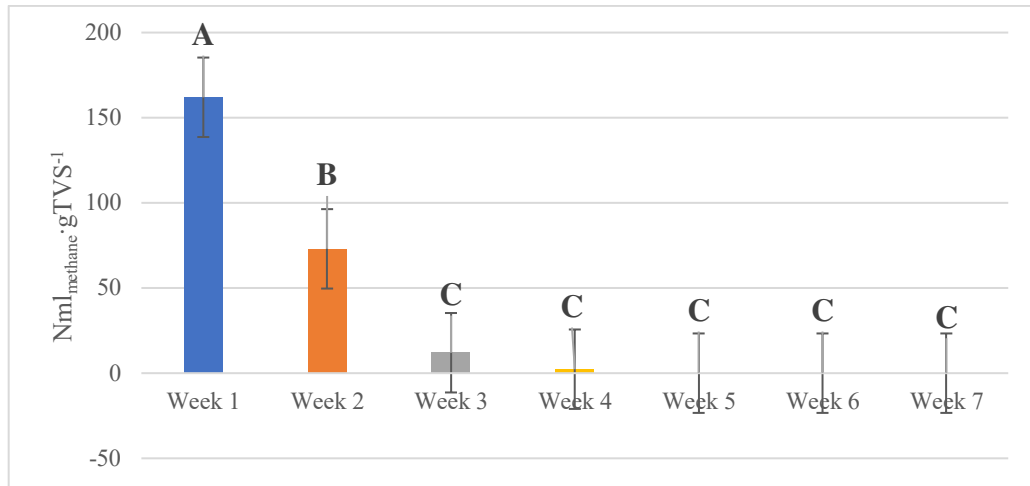

Figure 5.3 Production of $N_{ml_methane} \cdot gTVS^{-1}$ for the trial weeks. Data marked with different capital letters are significantly different by Tukey's test ($p < 0.05$).

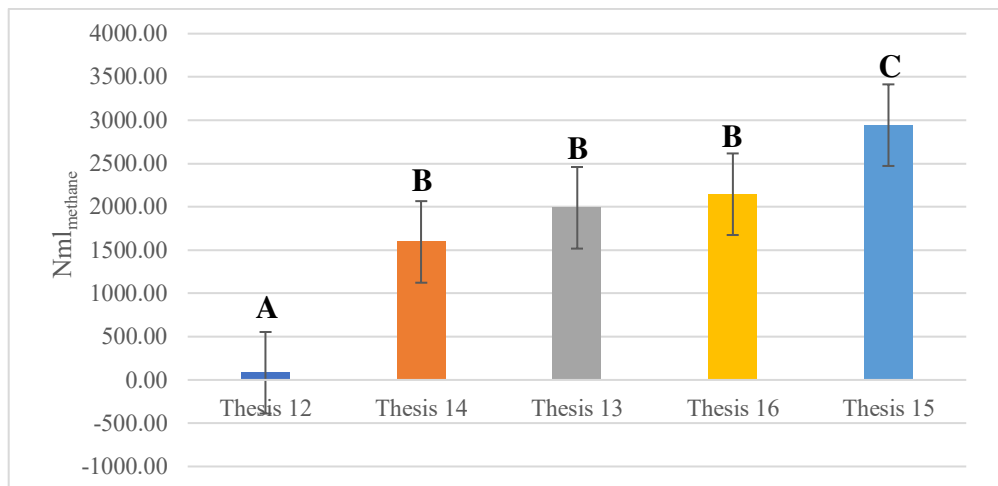

Figure 5.4 The graph shows that the most productive thesis was thesis 15 (C), with a production of $2942.91 \pm 3.15 N_{ml_methane}$. The least productive theses were theses 14, 13 and 16 (B). Data marked with different capital letters are significantly different according to Tukey's test ($p < 0.05$).

As shown in Figure 5.5 and 5.6, the highest methane yield, corresponding to $2.94 \pm 3.15 N_{ml_methane} \cdot gTVS^{-1}$ or $582.92 \pm 3.57 Nm^3/t[TVS]$, was obtained from the reactor containing 5% of the mixture containing 80% curd + 20% expired sausages, plus inoculum, while the lowest ($1.59 \pm 28.09 N_{ml_methane} \cdot gTVS^{-1}$ or $381.98 \pm 29.63 Nm^3/t[TVS]$) was obtained from the reactor containing 5% of the mixture containing 80% curd + 20% cooked rice.

Lisboa, M.S. and Lansing, S., (2013) conducted BMP tests to calculate methane yields from mixtures comprising 3.2% food waste and 96.8% manure (by volume), using waste from cranberry sauce production (CS), chicken fat for marinades (CK), meatball fat from frozen food processing (MB), and an ice cream processing plant (IC). All treatments led to a rise in methane production, ranging from a 67.0% increase (ice cream waste) to a 2940% increase (chicken processing waste) when compared to the digestion of manure only.

Karki, R et al., (2022) conducted an evaluation of anaerobic mono- and co-digestion of coffee pulp (CP), cattle manure (CM), food waste (FW), and dewatered sewage sludge (DSS).

The evaluation utilised methane biochemical potential tests at five different mixing ratios (1:0, 4:1, 2:1, 4:3, 0:1) based on volatile solids (TVS). The most productive mixture was the combination of FW and DSS, with FW mono-digestion showing a yield of 0,558 and 0,626 $\text{NL}_{\text{methane}} \cdot \text{gTVS}^{-1}$ added.

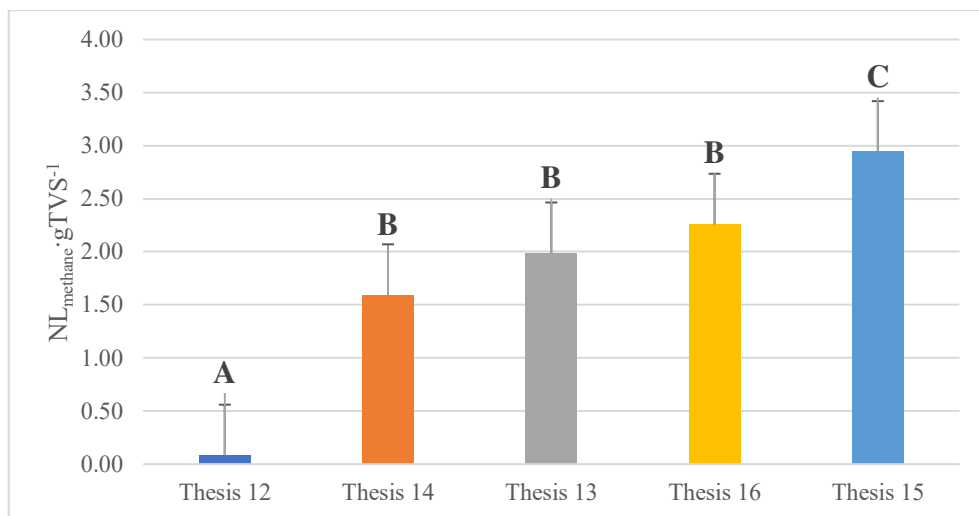

Figure 5.5 The graph shows that the productive thesis was thesis 15 with $2.94 \pm 3.15 \text{ NL}_{\text{methane}} \cdot \text{gTVS}^{-1}$. The least productive theses were thesis 20 and 18 (B). The data marked with different capital letters are significantly different according to Tukey's test ($p < 0.05$).

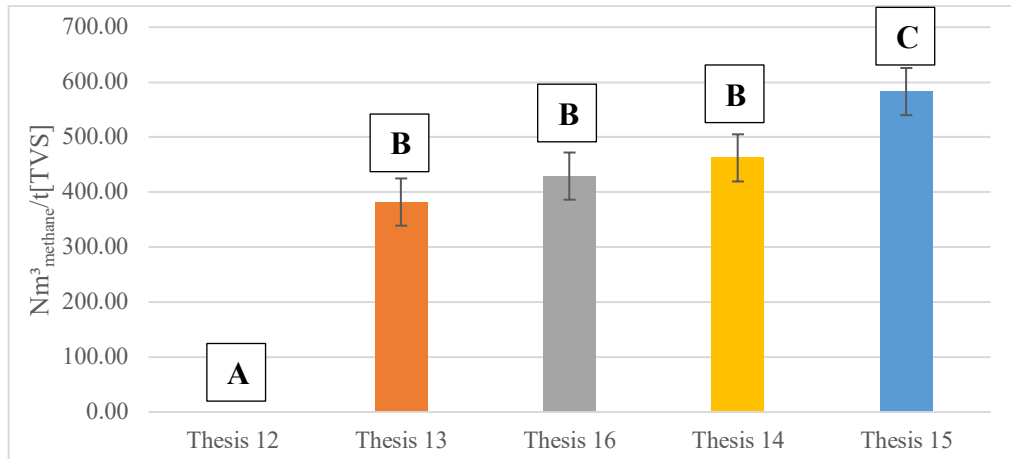

Figure. 5.6 The graph shows that the productive thesis was thesis 15 with $582.92 \pm 3.57 \text{ Nm}^3/\text{t}[\text{TVS}]$. The least productive theses were thesis 20 and 18 (B). The data marked with different capital letters are significantly different according to Tukey's test ($p < 0.05$).

5.6 Treatment efficiency

Tables 5.6 show the characterisations of the mixtures (substrate + inoculum) subjected to anaerobic digestion.

Tables 5.6 Physical-chemical characterization of the mixtures (substrate+inoculum) after BMP tests. Values expressed as mean of replicates \pm Dev. St.

	Unit	Thesis 12 (Control)	Thesis 13	Thesis 14	Thesis 15	Thesis 16
pH		8.03 \pm 0.38	8.22 \pm 0.12	8.16 \pm 0.43	8.29 \pm 0.85	8.16 \pm 0.26
TS	%	2.93 \pm 1.04	3.79 \pm 0.46	3.85 \pm 0.61	3.90 \pm 0.38	3.82 \pm 0.67
TVS on dry content	%	2.41 \pm 1.15	2.26 \pm 3.49	2.38 \pm 0.32	2.41 \pm 0.42	2.34 \pm 0.33
COD	g/kg	46.66 \pm 7.84	37.45 \pm 3.07	48.68 \pm 5.43	50.14 \pm 1.76	50.32 \pm 7.72
TKN	g/kg	2.41 \pm 1.15	3.46 \pm 8.25	3.08 \pm 0.39	3.39 \pm 0.84	3.17 \pm 0.15
NH ₄ ⁺ -N	g/kg	1.11 \pm 2.08	1.80 \pm 1.65	1.60 \pm 1.60	1.88 \pm 0.83	1.72 \pm 0.97
Total VFA	mg/l	20.53 \pm 4.83	26.03 \pm 27.13	21.88 \pm 1.90	28.11 \pm 16.32	20.91 \pm 6.14
Polyphenols	mg/kg	0.57 \pm 4.88	0.54 \pm 8.59	0.51 \pm 3.67	0.54 \pm 2.73	0.49 \pm 3.28

As shown in table 5.7 even without the addition of buffer, the pH remained nearly neutral during the tests, with all treatments having non-statistically significant decreases in pH during digestion.

Table 5.7 Initial pH and final pH of the theses

Theses	Initial pH	Final pH
Thesis 12 (Control)	7.88	8.03
Thesis 13	8.73	8.22
Thesis 14	8.14	8.16
Thesis 15	8.13	8.29
Thesis 16	8.09	8.16

As show in table 5.8, between 11% and 42% of the initial VS was degraded during the 46-day test (six week), with thesis 15 (5% of the mixture containing 80% curd +20% expired sausages + 95% inoculum) having the greatest reductions in TVS (42%) and thesis 16 (5% of the mixture containing 80% curd +20% cooked pasta + 95% inoculum) having the lowest reduction in TVS (9%).

Table 5.8 Percentage abatement of Volatile Solids. Results are expressed as percentage abatement of VS.

Theses	TVS pre-digestion (g/kg)	TVS post-digestion (g/kg)	Abatement % TVS
Thesis 12 (Control)	12.65±0.58	9.32±1.21	26%
Thesis 13	13.53±2.63	8.77±1.20	35%
Thesis 14	14.00±0.06	9.26±1.70	34%
Thesis 15	15.76±0.15	9.10±3.58	42%
Thesis 16	14.09±16.28	12.58±15.47	11%

While Table 5.9 shows the COD abatement, between 14% and 57% of the initial COD was degraded during the 42-day test (six weeks), with thesis 16 (5% of the mixture containing 80% curd +20% cooked pasta + 95% inoculum) having the greatest COD reductions (72%) the other theses did not have appreciable reductions.

Table 5.9 Percentage abatement of COD. Results are expressed as percentage abatement of COD.

Theses	COD pre-digestion (g/kg)	COD post-digestion (g/kg)	Abatement %COD
Thesis 12 (Control)	40.29±35.77	41.74±8.92	N.D
Thesis 13	36.73±8.38	39.54±14.54	N.D
Thesis 14	30.91±31.51	48.74±4.94	N.D
Thesis 15	51.39±3.19	51.20±689	N.D
Thesis 16	44.84±0.78	12.58±15.47	72%

5.7 Conclusion

The results obtained in this second trial were very promising and reconfirm the reliability of the anaerobic digestion process to recover energy from agri-food by-products and food waste. The co-digestion of dairy and food waste could obviate the seasonality problems of individual matrices by allowing biogas plants to work without supply interruptions. Furthermore, the results of this experiment made it possible to start up two reactors continuously mixed and fed on a daily basis.

References

Cecchi, F.; Battistoni, P.; Pavan, P.; Bolzanella, D.; Innocenti, L. *Digestione Anaerobica Della Frazione Organica dei Rifiuti Solidi*; APAT: Rome, Italy, 2005; p. 178.

Hülsemann B, Zhou L, Merkle W, Hassa J, Müller J, Oechsner H. Biomethane potential test: Influence of inoculum and the digestion system. *Appl Sci*. 2020;10(7).

Jiang J, Li L, Cui M, Zhang F, Liu Y, Liu Y, et al. Anaerobic digestion of kitchen waste: The effects of source, concentration, and temperature. *Biochem Eng J* . 2018;135:91–7. Available from: <https://doi.org/10.1016/j.bej.2018.04.004>

Karki, R., Chuenchart, W., Surendra, K. C., Sung, S., Raskin, L., & Kumar, S. (2022). Bioresource Technology Anaerobic co-digestion of various organic wastes : Kinetic modeling and synergistic impact evaluation. *Bioresource Technology*, 343(September 2021), 126063. <https://doi.org/10.1016/j.biortech.2021.126063>

Kazimierowicz, J.; Dzienis, L.; Debowski, M.; Zielinski, M. Optimisation of methane fermentation as a valorisation method for food waste products. *Biomass Bioenergy* 2021, 144, 105913.

Lebuhn, M.; Bauer, C.; Gronauer, A.: Probleme der Biogasproduktion aus nachwachsenden Rohstoffen im Langzeitbetrieb und molekularbiologische Analytik. *VDLUFA-Schriftenreihe* 64, 2008, pp. 118–125

Lisboa, M.S. and Lansing, S. 2013. Characterizing food waste substrates for co-digestion through biochemical methane potential (BMP) experiments. *Waste Management*, 33(12), 2664–2669. <https://doi.org/10.1016/j.wasman.2013.09.004>

Meng, Y.; Li, S.; Yuan, H.; Zou, D.; Liu, Y.; Zhu, B.; Chufo, A.; Jaffar, M.; Li, X. Evaluating biomethane production from anaerobic mono- and co-digestion of food waste and floatable oil (FO) skimmed from food waste. *Bioresour. Technol.* 2015, 185, 7–13.

Singleton, V.L.; Orthofer, R.; Lamuela-Raventós, R.M. Analysis of total phenols and other oxidation substrates and antioxidants by means of folin- ciocalteu reagent. *Methods Enzymol.* 1999, 299, 152–178

Teixeira, R.A.; Bueno, B.A.; Borges, R.M.; Bringhenti, J.R. Biochemical Methane Potential of Spent Coffee Grounds via Co-digestion with FoodWaste. *BioEnergy Res.* 2021, 1–12.

VDI 4630 INGENIEURE. In *Fermentation of Organic Materials: Characterisation of the Substrate, Sampling, Collection of Material Data, Fermentation Tests*; Verlag des Vereins Deutscher Ingenieure: Düsseldorf, Germany, 2006.

Zala, M., Solanki, R., & Purnanand Bhale, V., and Vaishak S. 2020. Experimental investigation on anaerobic co-digestion of food waste and water hyacinth in batch type reactor under mesophilic condition. *Biomass Conversion and Biorefinery* (2020) 10:707–714. doi.org/10.1007/s13399-019-00522-1

6. EXPERIMENTAL DESIGN N.3: Anaerobic co-digestion of mixtures composed of three substrates from the dairy industry and different agri-food wastes.

Abstract

The research activity was designed on the basis of the results of the previous experiment. The BMP test was performed on mixtures consisting of the most productive substrates, in terms of bio-methane production, identified in the previous experiment. The tests were carried out under mesophilic conditions (37°C). The ratio of substrate to inoculum was kept below 0.5. Each day, the biomethane produced was evaluated using the water displacement methodology and measured against standard temperature and pressure conditions (T=0°C and P=1013 hPa). The highest methane yield, corresponding to $4.90 \text{ NI}_{\text{methane}} \cdot \text{gTVS}^{-1}$ or $610.20 \text{ Nm}^3/\text{t}[\text{TVS}]$, was obtained from the reactor containing a mixture of 70% curd + 15% bakery products and 15% cooked pasta.

Keywords: anaerobic co-digestion; bio-methane, BMP test, mesophilic conditions, sustainable energy.

6.1 Introduction

In the previous experiment, a study was conducted on anaerobic co-digestion, i.e. the use of a mixture of two substrates which, when mixed with inoculum and subjected to an anaerobic regime, produces biogas. In this second phase, mixtures containing three different substrates were tested; the base mixture consisted of 70% curd + 15% bakery products and the remaining 15% from a different matrix.

This experiment was designed to test the co-digestion of different substrates, as heterogeneous mixtures consisting of different types of waste are used in real digestion plants. For this reason, it was decided to use different substrates in order to find the most productive recipe in terms of biomethane produced. Several authors have studied the co-digestion of agri-food by-products and food waste for biogas production.

Valenti, F. et al., (2018) tested co-digestion of different types of agricultural residues (citrus pulp, olive pomace, cattle manure, poultry litter, whey and maize silage) to produce biogas. The mixtures, for the BMP test, were prepared by mixing the waste

with the inoculum at an TVS ratio of 1:2. Batch anaerobic co-digestion showed that six feedstock mixtures studied generated an average of $0.24 \text{ NL}_{\text{methane}} \cdot \text{gTVS}^{-1}$ with no significant differences between them. Kassongo, J. et al., (2020) assessed the potential for bio-methane production using mixtures containing distilled grape marc (GM) and whey extracted from cheddar cheese processing as substrates. Digestion of raw materials in a 3/1 GM/CW ratio (w/w) was conducted under thermophilic (45°C) and non-shaking conditions, after optimisation using the Taguchi method. The cumulative yields of biogas and methane were respectively $0.601 \text{ NL}_{\text{methane}} \cdot \text{gTVS}^{-1}$ e $363.3 \text{ Nm}^3/\text{t}[\text{TVS}]$. da Chuna et al., (2021) tested anaerobic digestion using mixtures of sewage sludge (SS) and fresh food waste (FDA) or pre-fermented (80:20% v/v) using bench digesters. They performed better with $0.186\text{--}0.223 \text{ NI}$ of biogas/g TVS) than the sludge-only digester with 0.41 NI of biogas/g $\text{TVS}_{\text{added}}$). Orangun et al., (2021) used sheep manure in co-digestion with food waste from commercial activities. The experiments were conducted in mesophilic conditions (37°C) with an inoculum/substrate ratio of two. Biomethane was measured by the water displacement method. The cumulative yields in the mono-digestions of goat manure and food waste were 0.170 and 0.206 NI/gTVS , respectively. Among the co-digestions, 60% of goat manure achieved the highest biomethane yields of 0.381 NI/gTVS . Kaintholal et al., (2020) tested the methane potential of rice straw and co-digested food waste. The co-digestion of rice straw and food waste for C/N 30 showed a methane yield of $323.78 \text{ ml/gTVS}_{\text{added}}$ (94.41%), $166.54 \text{ ml/gTVS}_{\text{added}}$ higher than the monodigestion (control). Ihoeghian, A., et al., (2022) analysed the batch co-digestion of cattle rumen content (CRC) and food waste (FW) for biogas production in different ratios (CRC:FW). The 50:50 co-digestion ratio was optimal as it provided the highest cumulative biogas yield of $0.320 \text{ NL}_{\text{methane}} \cdot \text{gTVS}^{-1}$.

6.2 Materials and methods

As already mentioned, the experimental set-up was the same as in previous experiments. As mentioned above, before preparing and filling the reactors, the mixtures were subjected to a chemical-physical characterization and only after calculating the most appropriate ratio of substrate to inoculum was it possible to start the experiment. Curd was chosen as the basis for the production of the mixtures because it produced the highest amount of biomethane $2.65 \pm 20.13 \text{ Nm}^3_{\text{methane}} \cdot \text{gTVS}^{-1}$ or $610.87 \pm 4.51 \text{ Nm}^3/\text{t[TVS]}$. Non-edible curd accounted for the largest quantity in the mixtures 70%, bakery products were used for another 15%, and another type of substrate of animal and plant origin was used for the remaining 15%. The preparation and set-up of the reactors will be discussed in detail below.

6.3 Physical-chemical characterization of the substrates

The mixtures chosen in this part of the experiment are schematically represented in Table 6.1. Each mixture was prepared on 500 g final. Each percentage of substrate was weighed and then homogenised using a domestic mixer (Blendec, Vaso Wildside Flow).

Table 6.1 Experimental set-up and reactors content

	Thesis 18	Thesis 19	Thesis 20
Curd	70%	70%	70%
Bakery products	15%	15%	15%
Cheese whey	15%	-	-
Cooked pasta	-	15%	-
Expired sausages	-	-	15%

Exactly as in the last experiment and, as reported in the Chapter 3., before conducting all BMP tests, all mixtures, including the inoculum, were characterized from a chemical-physical point of view to correctly set the substrate content in the reactor, identify appropriate process parameters and avoid inhibitory effects. Specifically, pH was measured with a pH probe (XS PH 8+ DHS laboratory pH

meter), total solids TS (%) were determined at 105 °C with a moisture analyser (Ohaus, MB120), total volatile solids TVS (% of dry content) were determined after ignition at 550 °C with a muffle furnace (Heraeus, M110) (Epa, U.S., and O.W. Office, 2001). The chemical oxygen demand (COD) (g.l^{-1}) was measured following the COD measurement method for high concentration samples. In addition, the content of total polyphenols (PPs) was measured according to the Folin Ciocalteu method (Singleton V.L. et al. 1999). Total Kjeldahl Nitrogen (TKN) and ammonium contents were quantified using an autodistiller (B.U.C.H.I, Autokjeldahl unit k370). Total volatile fatty acids VFA were quantified by HPLC high-performance liquid chromatography (Agilent GC-1200).

6.4 Experimental set-up and bmp test

Static BMP analyses, on the substrate mixtures, were conducted at two different times. In a first step, mixtures containing two substrates were tested, and only in a second step were mixtures containing three substrates tested. The tests, again, were conducted on a laboratory scale simulating, in a controlled environment, what takes place in an anaerobic digester. Exactly as mentioned above, the mixtures (%substrates+%inoculum) were prepared as illustrated in Fig. 1 and placed in laboratory reactors using half-filled 1000 ml DURAN® GL 45 bottles. Before being sealed, the reactors were insufflated with nitrogen gas (N_2) to ensure an anaerobic medium and then hermetically connected to another bottle containing a 3M sodium hydroxide solution to absorb CO_2 . The latter was connected via a siphon system to a bottle containing water to measure the volume of biomethane (Figure 6.1).

The reactors were incubated in a climatic chamber at 37°C to ensure mesophilic conditions with a retention time of at least 29 days or four weeks (Figure 6.2).

The tests were conducted considering three replicates for each thesis, for a total of 12 reactors.

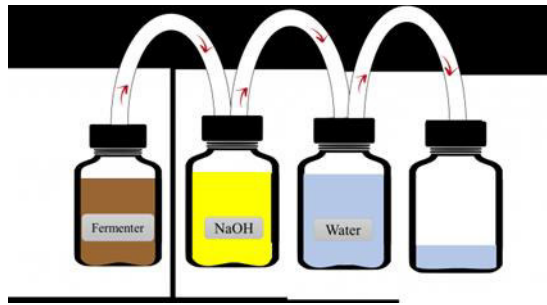

Figure 6.1 Graphical set-up of the BMP test with water displacement method for biomethane quantitation.



Figure 6.2 Reactors placed inside the climatic chamber at 37 °C

Chemical-physical characterisation analyses were carried out both on the individual substrates prior to mixing with the inoculum, and on the mixtures subjected to anaerobic digestion. Tables 6.2. show the results of the characterisation of each substrate. Next, the calculation of the percentage of substrate on the inoculum was carried out. To avoid inhibiting effects, the amount of total volatile solids (TVS) of the substrate must not exceed the amount of volatile solids of the inoculum.

In fact, the ratio between the two values must be kept below 0.5 (V. Verg, S. Substratcharakterisierung, and V. D. 2006). The analyses allowed the preparation of individual mixtures as show in Table 6.3.

Table 6.2 Physical-chemical characterization of the substrates subjected to BMP tests. Values expressed as mean of replicates \pm Dev. St.

	Unit	Inoculum III	70%curd + 15% bakery products + 15% cheese whey	70%curd + 15% bakery products + 15% cooked pasta	70%curd + 15% bakery products + 15% expired sausages
pH		8.18	5.04	4.46	5.05
TS	%	3.89 \pm 1.05	26.09 \pm 0.05	31.15 \pm 1.29	29.48 \pm 0.24
TVS on dry content	%	2.46 \pm 2.47	25.25 \pm 0.05	30.35 \pm 1.43	28.59 \pm 0.30
COD	g/kg	40.75 \pm 5.14	52094 \pm 3.16	518.31 \pm 3.18	462.37 \pm 11.16
TKN	g/kg	2.82 \pm 0.93	16.09 \pm 1.21	18.33 \pm 0.49	17.52 \pm 3.80
NH ₄ ⁺ -N	g/kg	1.26 \pm 0.98	1.67 \pm 1.52	1.89 \pm 0.85	1.83 \pm 2.14
Total VFA	mg/l	35.07	304.76	251.35	295.21
Polyphenols	mg/kg	0.74 \pm 0.024	1.36 \pm 0.019	1.64 \pm 0.145	1.54 \pm 0.032

Table 6.3 Experimental set-up and reactors content.

	Thesis 17	Thesis 18	Thesis 19	Thesis 20
Inoculum	100%	96%	95%	97%
70%curd + 15% bakery products + 15% cheese whey	-	4%	-	-
70%curd + 15% bakery products + 15% cooked pasta	-	-	5%	-
70%curd + 15% bakery products + 15% expired sausages	-	-	-	3%

6.5 Results and discussion

Tables 6.4. show the results of the physical-chemical characterisation of the mixtures that were subjected to AD. We can observe that the AD of all mixtures was performed in a wet medium, as the total solids content is well below 10% (Cecchi et al., 2005). The pH of all mixtures was in line with the limit values between 6.5 and 8 (Lebuhn et al., 2008). The pH ranged between 8.18 ± 0.01 for thesis 17 contained the inoculum used as buffer and 7.94 ± 0.01 for thesis 19 containing the mixture consisting of 70% curd 15% bakery products and 15% cooked pasta.

The pH measurement provided an indication of the stability of the process, in fact no anomalies were recorded during the entire digestion phase (Cecchi et al., 2005).

Table 6.4 Physical-chemical characterization of the mixtures (substrate+inoculum) subjected to BMP tests. Values expressed as mean of replicates \pm Dev. St.

	Unit	Thesis 17	Thesis 18	Thesis 19	Thesis 20
pH		8.18	8.06	7.94	8
TS	%	3.89 ± 1.05	5.38 ± 0.18	5.25 ± 0.26	5.12 ± 0.30
TVS on dry content	%	2.46 ± 2.47	3.87 ± 0.27	3.76 ± 0.24	3.59 ± 0.41
COD	g/kg	40.75 ± 5.14	66.65 ± 6.28	65.12 ± 4.76	65.55 ± 4.17
TKN	g/kg	2.82 ± 0.93	3.80 ± 2.16	3.80 ± 1.77	3.69 ± 1.04
NH ₄ ⁺ -N	g/kg	1.26 ± 0.98	1.44 ± 1.62	1.46 ± 0.61	1.46 ± 1.82
Total VFA	mg/l	35.07	1278.59	1315.75	1330.57
Polyphenols	mg/kg	0.74 ± 0.024	1.22 ± 0.033	1.12 ± 0.022	0.83 ± 0.026

The obtained biomethane volumes (Table 6.5) were normalised at standard temperature and pressure conditions ($T = 0 \text{ }^\circ\text{C}$ and $P = 1013 \text{ hPa}$) according to the procedures described in VDI 4630. For this experiment, which consisted of four theses (considering three replicates for each theses) for a total of 12 reactors and was carried out over a period of 29 days or four weeks, an analysis of variance was

carried out to check whether there were differences in CH₄ production for the weeks and hypotheses considered.

Table 6.5 Cumulative methane yield and percentage of CH₄. Results are expressed ad mean±Dev.St.

Theses	V(CH ₄) N _{l_{methane}} ·gTVS ⁻¹	CH ₄ %
Thesis 17 (Control)	0.14±15.64	78.9
Thesis 18	3.89±0.39	81.7
Thesis 19	4.84±4.90	80
Thesis 20	3.33±10.56	82.3

The Anova test conducted for CH₄ yield produced was significant at both week [F(3,3)] = 53,162, p < 0,05 and theses [F(3,3)] = 20,611, p < 0,05.

Figure 6.3 shows that during the first week of operation (C), all the reactors in this experiment produced large quantities of biomethane; whereas from the second week onwards, there is an increasing reduction (B), until the third and fourth weeks, where production collapsed dramatically (A).

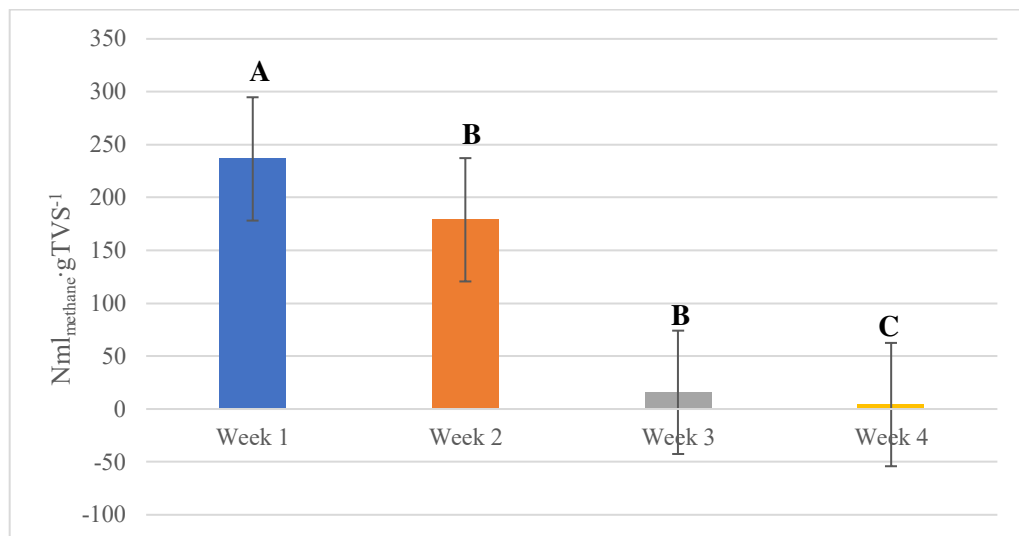

Figure 6.3 Production of Nml_{methane}·gTVS⁻¹ for the trial weeks. Data marked with different capital letters are significantly different by Tukey's test (p < 0.05).

While in Figure 6.4. it can be seen that, in terms of normalised methane production; control A (thesis 17= inoculum), as expected, had the lowest bio-methane production. Thesis 20 (70% curd +15% bakery products +15% expired sausages) belongs to group B, had the same production trend; thesis 18 (70% curd+ 15% bakery products + 15% cheese whey) belongs to group BC.

The most productive thesis was thesis 19 (70%curd+ 15% bakery products + 15% cooked pasta) belonging to group C.

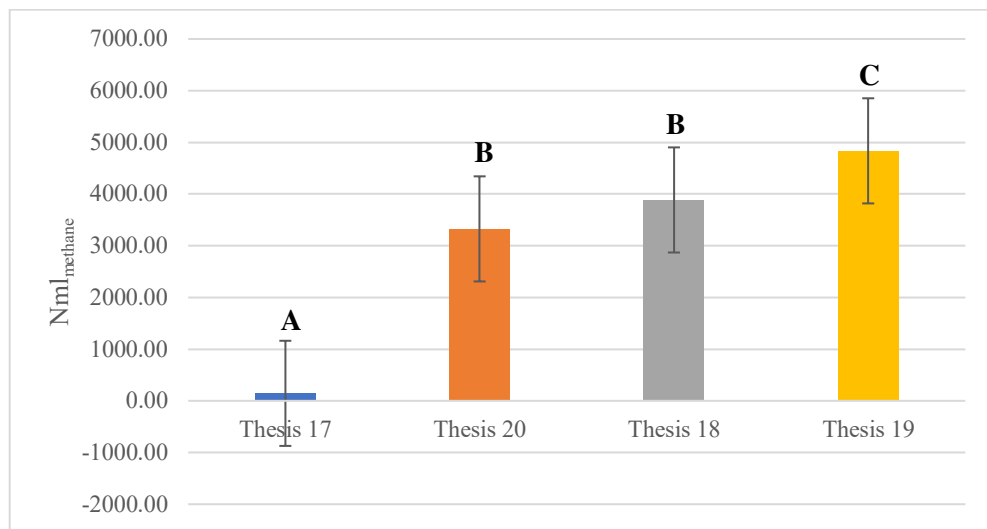

Figure 6.4 The graph shows that the most productive thesis was thesis 19 (C), with a production of $4835.79 \pm 4.902.65$ Nm_{methane}. The least productive theses were thesis 20 and thesis 18 (B). Data marked with different capital letters are significantly different according to Tukey's test ($p < 0.05$).

As shown in Graphs 6.5. and 6.6, the highest methane yield, corresponding to 4.84 ± 4.90 N_{methane}·gTVS⁻¹ or 641.57 ± 1.29 Nm³/t[TVS], was obtained from the reactor containing 5% of the mixture containing 70% curd + 15%bakery products + 15% cooked pasta, plus inoculum, while the lowest (3.33 ± 10.56 N_{methane}·gTVS⁻¹ or 610.75 ± 11.55 Nm³/t[TVS]). was obtained from the thesis 18 containing 5% of the mixture containing 70% curd + 15% bakery products + 15% cheese whey.

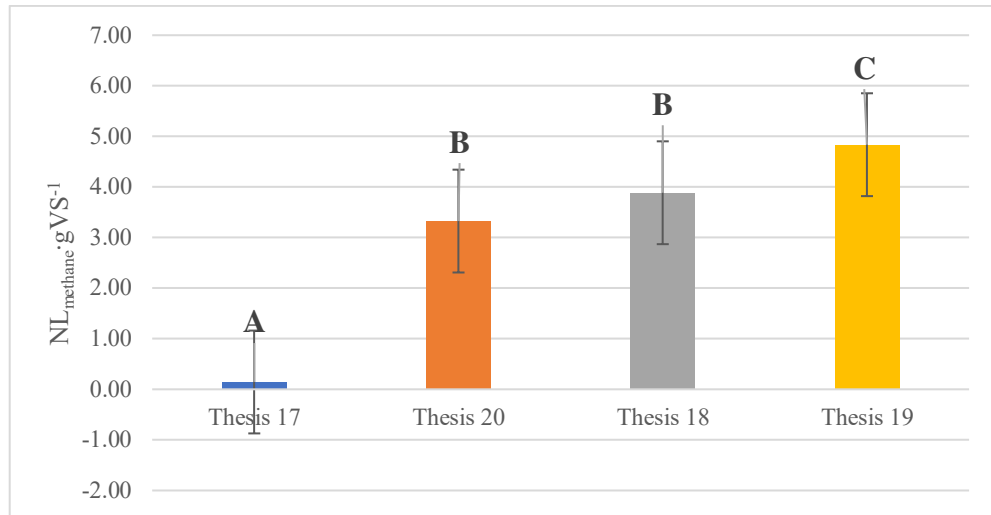

Figure 6.5 The graph shows that the productive thesis was thesis 19 with $4.84 \pm 4.90 \text{ NL}_{\text{methane}} \cdot \text{gTVS}^{-1}$. The least productive theses were thesis 20 and 18 (B). The data marked with different capital letters are significantly different according to Tukey's test ($p < 0.05$).

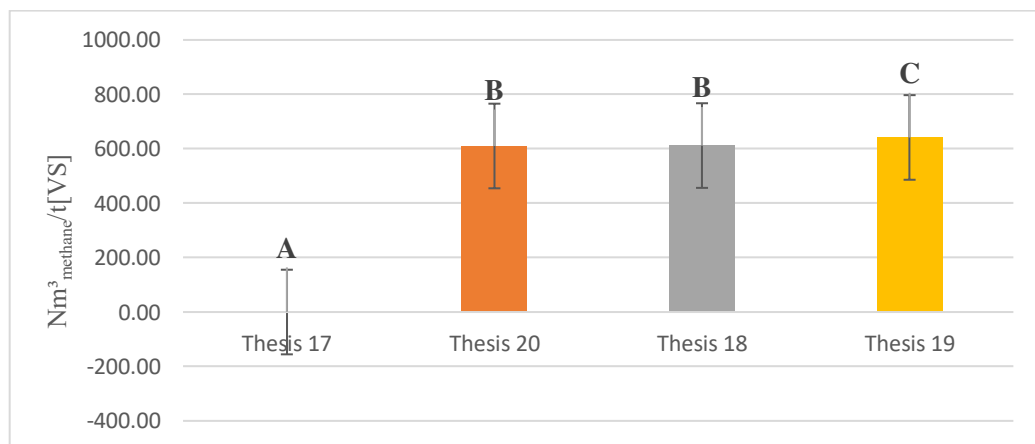

Figure. 6.6 The graph shows that the productive thesis was thesis 19 with $641.57 \pm 1.29 \text{ Nm}^3_{\text{methane}}/\text{t[TVS]}$. The least productive theses were thesis 20 and 18 (B). The data marked with different capital letters are significantly different according to Tukey's test ($p < 0.05$).

6.6 Treatment efficiency

Table 6.6 show the characterization of the mixtures (substrate+inoculum) subjected to anaerobic digestion.

Table 6.6 Physical-chemical characterization of the mixtures (substrate+inoculum) subjected to BMP tests. Values expressed as mean of replicates \pm Dev. st

	Unit	Thesis 17 (Control)	Thesis 18	Thesis 19	Thesis 20
pH		8.06 \pm 0.50	7.79 \pm 0.45	7.80 \pm 0.61	7.73 \pm 0.65
TS	%	4.11 \pm 0.46	4.12 \pm 0.53	4.14 \pm 0.79	4.14 \pm 0.66
TVS on dry content	%	2.59 \pm 0.63	2.59 \pm 1.06	2.63 \pm 1.01	2.61 \pm 0.70
COD	g/kg	30.72 \pm 22.88	51.55 \pm 6.13	50.80 \pm 6.09	48.62 \pm 3.35
TKN	g/kg	3.12 \pm 0.60	3.77 \pm 0.33	3.97 \pm 0.66	3.68 \pm 1.04
NH ₄ ⁺ -N	g/kg	1.47 \pm 0.57	2.07 \pm 5.48	2.22 \pm 0.74	1.97 \pm 0.97
Total VFA	mg/l	0	275.00 \pm 55.30	200.00 \pm 64.95	116.67 \pm 12.37
Polyphenols	mg/kg	0.75 \pm 9.31	0.78 \pm 6.28	0.82 \pm 2.09	0.71 \pm 4.01

As show in table 6.7 even without the addition of buffer, the pH remained almost neutral during the tests, with all treatments registering non-statistically significant pH decreases during digestion. it is natural that there are pH fluctuations during the process.

Table 6.7 Initial pH and final pH of the theses.

Theses	Initial pH	Final pH
Thesis 17 (Control)	8.18	8.06
Thesis 18	8.06	7.79
Thesis 19	7.94	7.80
Thesis 20	8	7.73

In this test there was a stronger felling of the TVS (Table 6.8). Between 40% and 49% of the initial VS was degraded during the 29-day test, with thesis 18 (4% of the mixture consisting of 70% curd+15%bakery products+15%cheese whey + 96% inoculum) having the greatest reductions in TVS (49%) and thesis 20 (3% of the mixture consisting of 70% curd + 15%bakery products + 97% inoculum) having the lowest reduction in TVS (40%). The control (thesis 17), too did not have acceptable reductions in TVS.

Table 6.8 Percentage abatement of Volatile Solids. Results are expressed as percentage abatement of TVS.

Theses	TVS pre-digestion (g/kg)	TVS post-digestion (g/kg)	Abatement % TVS
Thesis 17 (Control)	9.61±1.87	10.65±1.31	N.D
Thesis 18	20.85±0.45	10.68±1.90	49%
Thesis 19	19.73±0.50	10.93±1.55	45%
Thesis 20	18.37±0.71	10.94±2.38	40%

As for the decrease in COD, between 22% and 25% of the initial COD was degraded during the 29-day test (4 weeks), with thesis 20 and 17 (3% of the mixture consisting of 70% curd + 15%bakery products + 97% inoculum) both having the greatest COD reductions (25%) and thesis 18 (4% of the mixture consisting of 70% curd+15%bakery products+15%cheese whey + 96% inoculum) having the lowest COD reduction (22%) was show in table 6.9.

Table 6.9 Percentage abatement of COD. Results are expressed as percentage abatement of COD.

Theses	COD pre-digestion (g/kg)	COD post- digestion (g/kg)	Abatement %COD
Thesis 17 (Control)	40.75±5.14	30.77±5.89	25%
Thesis 18	66.65±6.28	51.73±7.67	22%
Thesis 19	65.12±4.76	49.38±9.43	24%
Thesis 20	65.55±4.17	49.07±7.51	25%

6.7 Conclusion

The results obtained in this third trial were very promising and reconfirm the reliability of the anaerobic digestion process to recover energy from agri-food by-products and food waste. The co-digestion of dairy waste mixed with various agro-industrial wastes was very promising. Biomethane yields from all tested theses were very promising. In the future, different percentages could be tested with the ultimate aim of finding the mixture with the highest yield.

REFERENCES

Cecchi, F.; Battistoni, P.; Pavan, P.; Bolzanella, D.; Innocenti, L. *Digestione Anaerobica Della Frazione Organica dei Rifiuti Solidi*; APAT: Rome, Italy, 2005; p. 178.

da Cunha, A.P., Cammarota, M.C., Volschan Jr., I. Anaerobic co-digestion of sewage sludge and food waste: Effect of pre-fermentation of food waste in bench- and pilot-scale digesters. 2021. *Bioresource Technology Reports* 15 (2021) 100707. doi.org/10.1016/j.biteb.2021.100707

Hülsemann B, Zhou L, Merkle W, Hassa J, Müller J, Oechsner H. Biomethane potential test: Influence of inoculum and the digestion system. *Appl Sci.* 2020;10(7).

Ihoeghian, A., Amenaghawon, A.N., Ajieh, M.U., Oshoma, C.E., Ogoofure, A. Anaerobic co-digestion of cattle rumen content and food waste for biogas production: Establishment of co-digestion ratios and kinetic studies. 2022. *Bioresource Technology Reports* 18 (2022). doi.org/10.1016/j.biteb.2022.101033

Jiang J, Li L, Cui M, Zhang F, Liu Y, Liu Y, et al. Anaerobic digestion of kitchen waste: The effects of source, concentration, and temperature. *Biochem Eng J* [Internet].2018;135:91–7. doi.org/10.1016/j.bej.2018.04.004

Kainthola, J., Kalamdhad, A.S. and Vaibhav V. Goud, V.V. Optimization of process parameters for accelerated methane yield from anaerobic co-digestion of rice straw and food waste. 2020. *Renewable Energy* 149 (2020) 1352e1359. doi.org/10.1016/j.renene.2019.10.124

Kassongo, J., Shahsavari, E., & Ball, A. S. (2020). Biomass and Bioenergy Renewable energy from the solid-state anaerobic digestion of grape marc and cheese whey at high treatment capacity. *Biomass and Bioenergy*, 143(November), 105880. https://doi.org/10.1016/j.biombioe.2020.105880

Lebuhn, M.; Bauer, C.; Gronauer, A.: Probleme der Biogasproduktion aus nachwachsenden Rohstoffen im Langzeitbetrieb und molekularbiologische Analytik. VDLUFA-Schriftenreihe 64, 2008, pp. 118–125

Orangun, A., Kaur, H., and Raghava R. Kommalapati, R.R. Anaerobic batch co-digestion and analysis of the biochemical potential of methane from goat manure and food waste. 2021. *Energies* 2021, 14, 1952. doi.org/10.3390/en14071952

Singleton, V.L.; Orthofer, R.; Lamuela-Raventós, R.M. Analysis of total phenols and other oxidation substrates and antioxidants by means of folin- ciocalteu reagent. *Methods Enzymol.* 1999, 299, 152–178

Valenti, F., Zhong, Y., Sun, M., Porto, S. M. C., Toscano, A., Dale, B. E., Sibilla, F., & Liao, W. (2018). Anaerobic co-digestion of multiple agricultural residues to enhance biogas production in southern Italy. *Waste Management*, 78, 151–157. doi.org/10.1016/j.wasman.2018.05.037.

VDI 4630 INGENIEURE. In *Fermentation of Organic Materials: Characterisation of the Substrate, Sampling, Collection of Material Data, Fermentation Tests*; Verlag des Vereins Deutscher Ingenieure: Düsseldorf, Germany, 2006.

7. EXPERIMENTAL DESIGN N. 3: Continuous anaerobic co-digestion of a mixture of dairy industry waste and meat products using cstr reactors fed daily.

Abstract

The dairy and meat industries generate thousands of tonnes of organic waste and by-products each year, making them two of the least environmentally sustainable sectors. Typical waste includes not only processing by-products such as curds but also commercial products that are defective or unsaleable due to expiration or damaged packaging. This study aims to evaluate the methanogenic potential of a mixture of 80% inedible curds and 20% expired sausages using two continuous stirred tank reactors. The reactors were fed daily with increasing doses of the 80-20 mixture and a variable organic load rate. The anaerobic digestion process was evaluated by qualitative and quantitative measurements of the biogas produced daily. The process was monitored by taking daily samples from each reactor. The bio-chemicals parameters considered were pH, TS, TVS, COD, ammonium, TKN and total VFA. The results of this study show a promising increase in biogas production as the amount of feed increased, both in terms of biogas production and start-up and operating parameters, showing that biogas is a promising renewable energy sources that can contribution of biogas as a sustainable energy source towards achieving the sustainable development goals.

Keywords: CSTR, OLR, Methane, mesophilic conditions, sustainable energy.

7.1 Introduction

In Italy, the dairy and meat production and processing sectors represent the leading producers in the food industry. The dairy sector alone accounts for more than 12% of the total national food turnover, with a production value of over EUR 14.5 billion (ASSOLATTE, available online 25.11.2023). It is the most important component of the Italian food market, both in terms of domestic consumption as well as exports. The Italian dairy production reached 1,344,694 tons in 2020 while the meat production sector produced 4,481,000 tons in the same year (Clal, available 15.11.2023; Assalzoo, available 15.11.2023). The production and distribution of animal products, like in any other agri-food sector, is subject to various product

losses. For instance, products may no longer possess the necessary qualities to be sold, including defective or expired items. The disposal of these products is challenging due to their environmental impact. The waste can originate from manufacturing companies, large retailers, or individual consumers. The disposal of this waste represents a huge environmental cost, and from a sustainability perspective, anaerobic digestion could be the optimal process to recover these products energetically that are no longer fit for human consumption. In a circular economy and sustainability context, the biogas produced by the digestion process can be used as thermal energy for steam production or as a source of electricity for the wastewater treatment unit or operating machinery (Comino et al., 2009).

The solid and liquid fractions of anaerobic digesters contain valuable nutrients that can be used as fertilizer and soil conditioners (Kavacik et al., 2010). Therefore, anaerobic digestion of this waste type can decrease environmental pollution and save energy (Asunis et al., 2020; Hublin et al., 2012). One issue with this type of waste is its high organic load, which also makes it an ideal substrate for methane production in anaerobic processes. However, treating waste from animal origin anaerobically poses a challenge due to its high chemical oxygen demand (COD), low pH value, and lack of alkalinity (Kavacik et al., 2020).

In addition, dairy wastes with a low COD value, such as milk and yoghurt, may not be suitable for anaerobic digestion in conventional continuous stirred tank reactors (CSTR) type biogas plants (Karadag et al., 2015). Various reactor studies have shown that up-flow anaerobic sludge blanket (UASB) reactors are best suited for this kind of application with the highest COD removal efficiency.

A challenge is the presence of carbohydrates in dairy effluents promoting the growth of acidifying bacteria destabilizing the reactor by inhibiting the methanogenic bacterial consortium. To address this issue, researchers have suggested co-digesting dairy effluents with other waste materials, such as manure, goat straw litter, spent grain from brewing, cattle dung, poultry, or livestock waste (Lovato et al., 2019; Szaja et al., 2019; Fernández-Rodríguez et al., 2021).

These combinations can maintain the carbon/nitrogen (C/N) ratio and microbial synergism in a state that favours the growth of methanogenic bacteria, indirectly increasing biogas production (Gelegenis et al., 2007; Sar et al., 2021; Comino et al.,

2012). Escalante et al. (2017) determined the biomethane potential of dairy wastewater using cattle slurry as inoculum (Escalante et al., 2017).

The result of the Biochemical Methane Production test (BMP test) showed methane yields of 0.51-0.60 l CH₄/g TVS added. In line with the findings of Escalante et al. (2017), previous research has also reported BMP values for cheese whey (CW) between 0.32 and 0.85 l CH₄/g TVS (Escalante et al. 2017; Labatut et al., 2011; Dreschke et al. 2015). A literature search showed that mixtures containing by-products from the dairy and meat processing industries were barely discussed and tested. With a view to environmental sustainability and energy recovery from agri-food waste, this work is based on the anaerobic digestion of animal by-products for the production of biomethane. Specifically, a mixture containing 80% inedible curd and 20% expired sausage was tested. The experimental set-up involved the use of two normally fed and continuously stirred reactors (CSTR). The test was carried out under wet conditions with total solids (TS) < 10%, under mesophilic conditions (T = 37°C) and for a period of approximately 7 weeks (48 days).

7.2 MATERIALS AND METHODS

For the formulation of the experimental set-up of the mixtures, full reference was made to the results obtained from the batch tests conducted in the second experimental phase. The mixture, consisting of 80% curd and 20% expired sausages, was self-produced by curdling approximately 25 litres of whole cow's milk using an acid rennet, while the expired cold cuts were retrieved from the refrigerated counter of a supermarket. Two reactors were used in this experiment, both loaded with the same daily amounts of feed, and the anaerobic digestion process was conducted until the total exhaustion of the methanogenic potential of the bacterial consortium. The duration of the entire process was approximately 50 days.

7.3 The CSTR reactors

The reactors were built using appropriate materials to maintain an anoxic and pressure tight environment. The reactor, shown in Figure 7.1, consists of a digestion chamber, a stirring system and a system for qualitative and quantitative measurement of the methane produced. The reaction chamber is constructed of stainless steel plates enclosing a tempered glass cylinder which forms the core of the reactor. The stirring system is located at the top of the cylinder. It consists of a three-phase electric motor block connected to a gear motor to reduce the speed of the electric motor. In addition, a temperature probe and a biogas outlet are integrated, as indicated by Bernardi et al. (2017). The amount of gas produced is measured with a gas meter (Ritter TG 0.5 drum gas meter) and collected and stored in a gas bag connected downstream. Finally, the gas bag is connected to an Awite process analyser (AwiFLEX Cool+) for the qualification of the biogas produced. Ritter drum gas meters (wet test) are suitable for measuring the volume of gas in circulation with the highest accuracy.

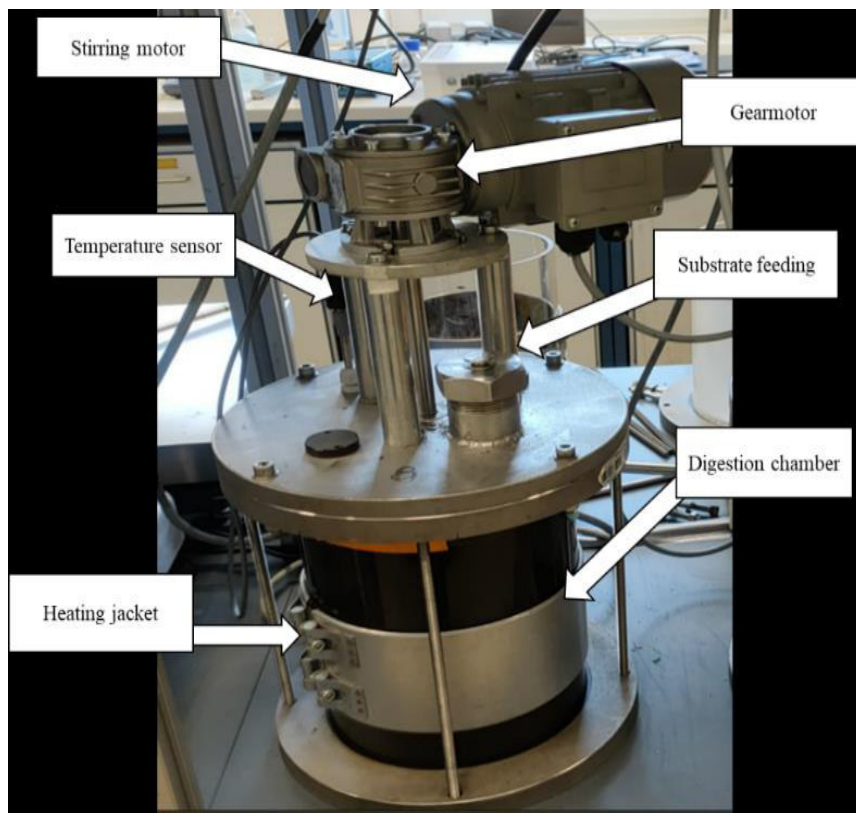

Figure 7.1 Reactor set-up

7.4 Experimental set-up

First, the physical-chemical characterization of the inoculum (anaerobic sludge from a local wastewater treatment plant) and the mixture was carried out, as shown in Table 7.1. Both reactors were filled with the same amount of inoculum (6 litres) and fed daily with the 80:20 mixture of curds and expired sausages paste, with increasing doses. Two reactors (1 and 2), with a capacity of 8 L, were filled with 6 L of inoculum and operated with the same process parameters. The experiment was conducted under mesophilic conditions (37°C) and lasted 48 days, i.e. approximately seven weeks. The entire process was carried out under wet conditions, i.e. with a total solids (TS) content < 10% (Cecchi et al. 2005).

The reactors were fed by gradually increasing the feed quantities. If the two reactors had been fed with a large amount of substrate right from the start, the bacterial consortium in the inoculum would not have been able to digest. Every three days or so, the reactor feed was increased and a sample was taken for analysis.

As the inoculum was not yet adapted to the substrate, the bacterial consortium had to be acclimatised gradually, and the feed had to be increased slowly. Since the inoculum was not adapted yet to the substrate, the feed had to be slowly increased. This was necessary to acclimatize the inoculum starting with minimal doses of substrate. As shown in Table 7.2 and 7.3, at starting time (T₀), the reactors were fed with only 6 g of substrate, every three days the dose was increased by a factor of two until 140 g of substrate in the final days of experimentation with a variable OLR. Every day, at the same time, before feeding the reactors, the parameters of pH, temperature and composition of the gases produced were measured.

Finally, every time the feed was increased (about every three days), an aliquot of the mass being digested, about 50 ml, was taken for physical-chemical characterization, assessing all the relevant reactor parameters. In detail, the pH was measured using a pH probe (XS PH 8+ DHS laboratory pH meter), total solids TS (%) were determined at 105 °C using a moisture analyzer (Ohaus, MB120), total volatile solids TVS (% of the dry content) were determined after ignition at 550 °C with a muffle furnace (Heraeus, M110) (Epa, U.S., and O.W. Office, 2001). Chemical oxygen demand (COD) (g.l⁻¹) was measured following the COD measurement method for high-concentration samples. Total Kjeldahl nitrogen

(TKN) and ammonium contents, were quantified using an auto-distiller (B.U.C.H.I, Autokjeldahl unit k370). Total volatile fatty acids VFA were quantified using high-performance liquid chromatography HPLC (Agilent series 1200).

The trial was conducted for 48 days with an OLR (Organic Load Rate) variable from 0.31 [gTVS /litre/day] (T1) to 0.77 [gTVS /litre/day] (T42).

Table 7.1 Chemical-physical characterisation of inoculum and mixture

	Unit	Inoculum	Thesis 11 (80% curd + 20% expired sausages)
pH		8.18	5.62
TS	%	3.89±1.05	32.21
TVS on TS	%	2.46±2.47	30.5
CSB	g/kg	40.75±5.14	433.37
TKN	g/kg	2.82±0.93	16.85
NH ₄ ⁺ -N	g/kg	1.260±0.98	2.39

Table 7.2 Reactor feed scheme g(feed)/day and its OLR (gTVS/liter/day)

Time	g of substrate used	Organic Load Rate	g of substrate used	Organic Load Rate
	to feed the reactor	[g TVS/liter/day]	to feed the reactor	[g TVS/liter/day]
	N°1	N°1	N°2	N°2
T1	6.10	0.31	6.11	0.31
T2	no feed		no feed	
T3	no feed		no feed	
T4	6.03	0.31	6.10	0.31
T5	6.09	0.31	6.09	0.31
T6	12.06	0.61	12.02	0.61
T7	12.04	0.61	12.16	0.62
T8	12.05	0.61	12.08	0.61
T9	20.16	1.02	20.06	1.02
T10	no feed		no feed	
T11	20.12	1.02	20.16	1.02
T12	20.07	1.02	20.17	1.03
T13	30.02	1.53	30.04	1.53
T14	30.1	1.53	30.06	1.53
T15	30.26	1.54	30.26	1.54
T16	40.41	2.05	40.36	2.05
T17	no feed		no feed	
T18	40.09	2.04	40.25	2.05
T19	40.21	2.04	40.09	2.04
T20	60.21	3.06	60.08	3.05
T21	60.78	3.09	60.71	3.09
T22	60.8	3.09	60.43	3.07
T23	80.27	4.08	80.15	4.07
T24	no feed		no feed	
T25	80.07	4.07	80.72	4.10

T26	80.23	4.08	80.58	4.10
T27	101.22	5.15	100.71	5.12
T28	100.56	5.11	100.37	5.10
T29	100.81	5.12	101.43	5.16
T30				
T31	no feed		no feed	
T32	119.66	6.08	119.35	6.07
T33	120.74	6.14	120.72	6.14
T34	119.61	6.08	121.21	6.16
T35	121.32	6.17	120.57	6.13
T36	119.73	6.09	119.49	6.07
T37				
T38	no feed		no feed	
T39	120.58	6.13	122.51	6.23
T40	120.05	6.10	120.27	6.11
T41	140.23	7.13	141.63	7.20
T42	139.9	7.11	140.51	7.14
T43				
T44				
T45	no feed		no feed	
T46				
T47	50.42	2.56	50.12	2.55
T48	no feed		no feed	
T49	end of experiment		end of experiment	

Table 7.3 Reactor feed scheme gTVS/day and gCOD/day

Time	feed/substrate TVS [g]	feed/substrate TVS	feed/substrate COD	feed/substrate COD
	reactor N°1	[g] reactor N°2	[g] reactor N°1	[g] reactor N°2
T0	1.86	1.86	26.44	26.48
T1	no feed		no feed	
T2	no feed		no feed	
T3	1.84	1.86	26.13	26.44
T4	1.86	1.86	26.39	26.39
T5	3.68	3.67	52.26	52.09
T6	3.67	3.71	52.18	52.70
T7	3.68	3.68	52.22	52.35
T8	6.15	6.12	87.37	86.93
T9	no feed		no feed	
T10	6.14	6.15	87.19	87.37
T11	6.12	6.15	86.98	87.41
T12	9.16	9.16	130.10	130.18
T13	9.18	9.17	130.44	130.27
T14	9.23	9.23	131.14	131.14
T15	12.32	12.31	175.12	174.91
T16	no feed		no feed	
T17	12.23	12.28	173.74	174.43
T18	12.26	12.23	174.26	173.74
T19	18.36	18.32	260.93	260.37
T20	18.54	18.52	263.40	263.10
T21	18.54	18.43	263.40	261.89
T22	24.48	24.44	347.87	347.35
T23	no feed		no feed	
T24	24.42	24.62	347.00	349.82
T25	24.47	24.58	347.69	349.21

T26	30.87	30.72	438.66	436.45
T27	30.67	30.61	435.80	434.97
T28	30.75	30.93	436.88	439.57
T29	no feed		no feed	
T30	no feed		no feed	
T31	36.49	36.40	518.57	517.23
T32	36.82	36.82	523.25	523.16
T33	36.48	36.97	518.35	525.29
T34	37.00	36.77	525.76	522.51
T35	36.52	36.44	518.87	517.83
T36	no feed		no feed	
T37	no feed		no feed	
T38	36.78	37.36	522.56	530.92
T39	36.61	36.68	520.26	521.21
T40	42.77	43.20	607.71	613.78
T41	42.67	42.85	606.28	608.93
T42	no feed		no feed	
T43	no feed		no feed	
T44	no feed		no feed	
T45	no feed		no feed	
T46	15.38	15.29	218.51	217.21
T47	0	0	0	0.00
T48	end of experiment		end of experiment	

7.5 Results and discussion

The results of the characterization of the biomass during digestion are shown in Tables 7.4 → 7.5 and 7.6 → 7.7. The pH in both reactors remained fairly constant throughout the experiment, although there was a slight acidification observed in both tests. The initial pH of 8.18 dropped down to a pH of 7.16 in reactor 1 and 7.32 in reactor 2 over 48 days until the end of the experiment. The pH also indicated the stability of the process, as its variation is associated both with the buffering capacity of the system and with changes in the balance between the species participating in the trophic chain of the microorganisms involved in the process. For pH values between 6.5 and 7.5, the digestion process is generally considered stable, although as we shall see in the results section, the variation that was recorded could be attributable to many intrinsic factors in the reactor. The measurement of this parameter indicated that an equilibrium condition existed in the system even when large quantities of substrate were added (T32 to T43), which did not affect the system. In both reactors, the total solids (TS) content always remained below 10% also at the end of the test. Given the increasing feed, the chemical and physical analyses conducted on the samples taken from the reactors (TS, TVS, TKN, $\text{NH}_4^+\text{-N}$, tVFA) showed exponential growth. The TVS content represents an approximation of the organic fraction of the substrate susceptible to conversion, thus allowing a preliminary estimate of the biogas to be produced (IEA; KTBL, 2015). The chemical oxygen demand COD is also an important parameter, as it allows to quantify the organic matter present in the samples and to have a rough estimate of biomethane production. Each gram of COD present in the sample will yield approximately 350 ml of CH_4 . V. Verg, S. Substratcharakterisierung and V.D.I. (2006). The fermentation of volatile fatty acids produces acetic acid, hydrogen and carbon dioxide. The concentration level of volatile acids, generally expressed in terms of acetic acid or COD, depends on the type of substrate being treated and varies from approximately 200 to 2000 $\text{mgAc}^{\text{l}^{-1}}$. Sudden increases of the VFA concentration indicate that the process is sliding towards acidogenic rather than methanogenic processes. In general, it can be observed that an increase in volatile acids is a consequence of the increased loading of the substrate to be treated, which results in the acceleration of hydrolytic and acidogenic phenomena. The imbalance of the trophic chain results from the shift of the system towards low pH conditions due to the depleted buffer capacity (Hülsemann et al. 2020). Ammonium nitrogen ($\text{NH}_4^+\text{-N}$) is one of the products of anaerobic digestion. If nitrogen-rich feedstocks are used, inhibition by ammonia is often the cause of process imbalance (KTBL, 2015). Therefore, monitoring the concentrations of ($\text{NH}_4^+\text{-N}$) in the digester helps to estimate whether ammonia inhibition is the cause of process imbalance.

Table 7.4 Reactor N°1: Physical-chemical characterization of samples taken from the reactors during the digestion phase. Values expressed as mean of replicates \pm Dev. St.

	Unit	T0	T3	T6	T9	T12	T15	T18
pH		8.19	7.46	7.40	7.44	7.47	7.55	7.62
TS	%	3.42 \pm 1.45	3.31 \pm 2.25	4.79 \pm 1.44	6.63 \pm 1.20	5.50 \pm 0.83	4.94 \pm 0.07	6 \pm 1.07
TVS on dry content	%	2.47 \pm 0.29	2.01 \pm 2.03	2.90 \pm 2.86	3.81 \pm 1.32	3.46 \pm 0.22	3.21 \pm 0.001	3.45 \pm 2.02
COD	g/kg	4.88 \pm 3.77	49.09 \pm 9.56	55.99 \pm 12.05	61.40 \pm 2.09	63.92 \pm 6.54	63.18 \pm 0.81	43.17 \pm 1.16
TKN	g/kg	2.81 \pm 0.76	4.82 \pm 55.07	3.35 \pm 1.27	4.07 \pm 0.35	4.24 \pm 3.34	4.25 \pm 0.5	5.32 \pm 0.27
Ammonium	%	1.26 \pm 0.56	1.20 \pm 1.78	1.38 \pm 0.51	1.71 \pm 0.83	1.91 \pm 5.57	2.01 \pm 0.7	3.02 \pm 1.17
Total VFA	mg/l	0	0	0	18.11	23.175	14.125	0

Table 7.5 Reactor N°1: Physical-chemical characterization of samples taken from the reactors during the digestion phase. Values expressed as mean of replicates \pm Dev. st.

	Unit	T21	T24	T27	T30	T33	T36	T39
pH		7.82	7.76	7.75	7.70	7.30	7.25	7.48
TS	%	5.55 \pm 1.3	4.11 \pm 12.61	4.11 \pm 1.21	4.08 \pm 1.63	4.62 \pm 1.84	4.84 \pm 0.29	5.07 \pm 0.98
TVS on dry content	%	3.40 \pm 2.99	2.47 \pm 1.29	2.89 \pm 1.38	2.80 \pm 2.60	3.13 \pm 1.13	3.49 \pm 1.42	4.02 \pm 0.35
COD	g/kg	44.91 \pm 0.68	28.43 \pm 10.77	41.40 \pm 1.73	50.07 \pm 0.14	51.22 \pm 0.47	51.38 \pm 0.5	51.83 \pm 0.14
TKN	g/kg	5.93 \pm 0.84	6.46 \pm 0.88	7.41 \pm 0.48	8.19 \pm 1.12	8.88 \pm 0.08	9.20 \pm 0.0	10.29 \pm 3.57
Ammonium	%	3.28 \pm 2.38	4.72 \pm 0.75	5.59 \pm 1.26	6.27 \pm 0.23	7.20 \pm 0.49	7.55 \pm 1.41	8.07 \pm 1.05
Total VFA	mg/l	29	50	31775	48525	88750	90126	91251

Table 7.6 Reactor N°2: Physical-chemical characterization of samples taken from the reactors during the digestion phase. Values expressed as mean of replicates \pm Dev. st.

	Unit	T0	T3	T6	T9	T12	T15	T18
pH		8.19	7.47	7.37	7.40	7.44	7.52	7.59
TS	%	3.42 \pm 1.45	3.59 \pm 2.37	4.18 \pm 0.53	6.48 \pm 0.13	4.87 \pm 19.04	5.04 \pm 0.70	7.84 \pm 14.56
TVS on dry content	%	2.47 \pm 0.29	2.20 \pm 2.18	2.38 \pm 0.50	3.61 \pm 0.40	3.51 \pm 0.54	3.30 \pm 0.31	3.99 \pm 13.96
COD	g/kg	4.88 \pm 3.77	8.87 \pm 50.51	36.91 \pm 37.77	65.06 \pm 6.59	60.99 \pm 2.65	59.34 \pm 3.20	41.30 \pm 1.39
TKN	g/kg	2.81 \pm 0.76	2.72 \pm 1.56	3.03 \pm 4.20	4.03 \pm 0.88	4.33 \pm 2.45	4.28 \pm 1.16	6.00 \pm 4.83
Ammonium	%	1.26 \pm 0.56	1.23 \pm 4.60	1.40 \pm 1.51	1.71 \pm 1.24	1.95 \pm 1.09	2.17 \pm 0.001	3.95 \pm 0.18
Total VFA	mg/l	0	19.465	0	18.62	26.465	33.015	0

Table 7.7 Reactor N°2: Physical-chemical characterization of samples taken from the reactors during the digestion phase. Values expressed as mean of replicates \pm Dev. St.

	Unit	T21	T24	T27	T30	T33	T36	T39
pH		7.84	7.70	7.67	7.67	7.43	7.42	7.51
TS	%	4.62 \pm 1.54	3.88 \pm 1.11	4.10 \pm 1.04	4.17 \pm 0.38	4.59 \pm 0.77	5.10 \pm 2.36	5.5 \pm 1.29
TVS on dry content	%	2.97 \pm 0.69	2.60 \pm 0.32	2.90 \pm 0.35	2.90 \pm 1.36	3.03 \pm 0.93	3.49 \pm 0.61	3.65 \pm 1.55
COD	g/kg	44.82 \pm 0.08	36.65 \pm 0.14	44.14 \pm 0.06	48.05 \pm 0.12	49.59 \pm 0.03	51.38 \pm 0.06	51.27 \pm 0.14
TKN	g/kg	6.39 \pm 3.54	6.68 \pm 1.17	7.54 \pm 0.56	8.31 \pm 0.85	9.21 \pm 3.00	9.86 \pm 0.86	10.09 \pm 0.84
Ammonium	%	3.47 \pm 0.001	4.79 \pm 0.74	5.66 \pm 0.38	6.33 \pm 0.11	7.06 \pm 0.60	7.62 \pm 0.37	8.08 \pm 0.96
Total VFA	mg/l	40	50	25550	41625	67950	70862	75265

The two reactors showed no significant differences, but throughout the experiment, the analysis values within each reactor changed, especially parameters such as the percentage of TVS or methane production. As shown in Figure 7.2, referred to the normalized litre of methane produced, there were no significant differences between the two reactors $F(1.71)=0.0000$ $P=0.990$.

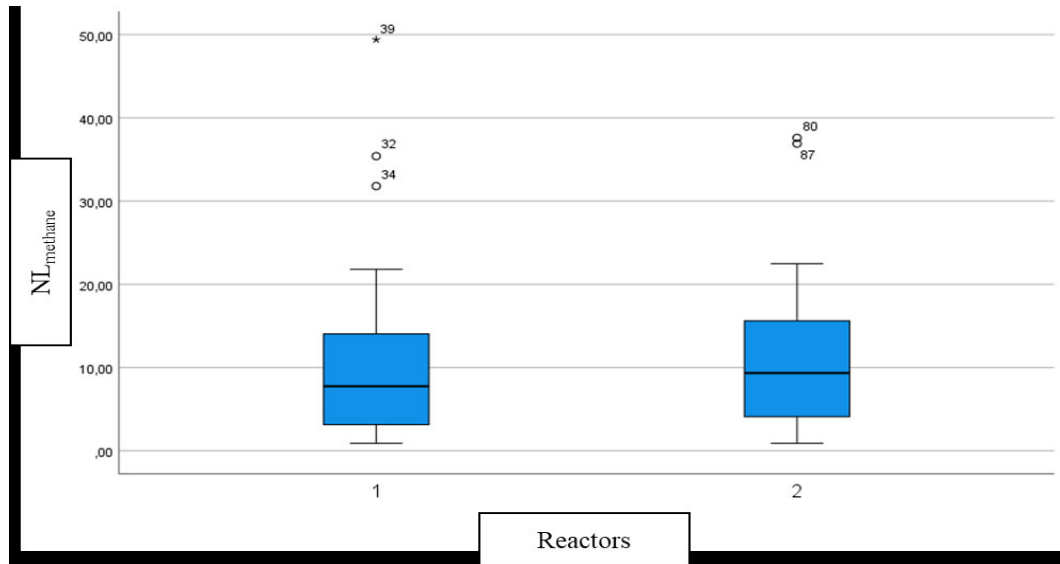

Figure 7.2 NLmethane cumulative production.

The daily and weekly CH₄ production are shown in Figures 7.3 and 7.4. In both reactors, there are significant differences in CH₄ production considering the production over a long time. When looking at the time evolution of the experiment over seven weeks, during the first week of the experiment, both reactors produced low quantities of biogas (± 10 NL_{methane}). Over time the biogas production increased between the third and fourth week, reaching a maximum during the fifth week, followed by a gradual decreasing in weeks 7.6 and 7.7.

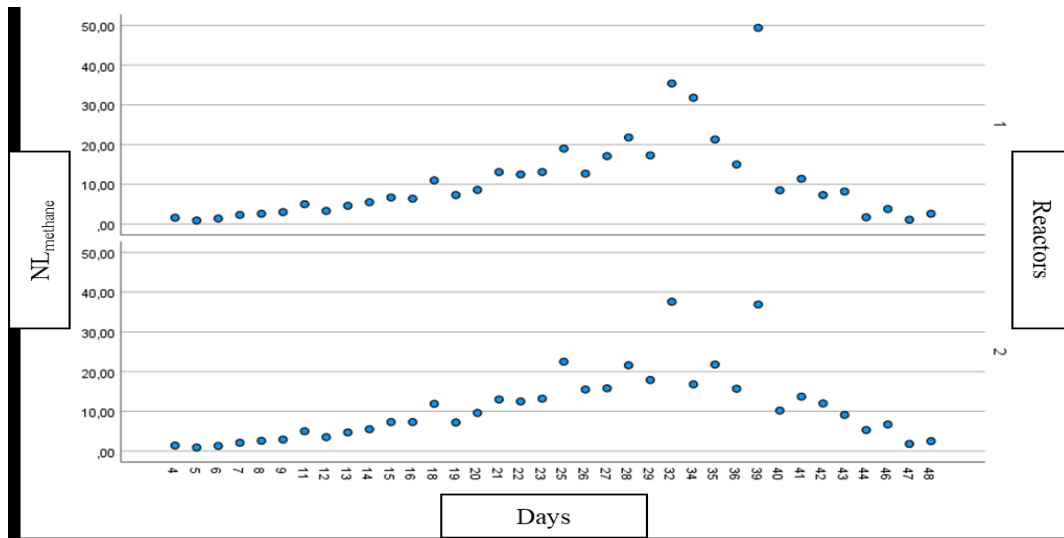

Figure 7.3 Daily production of $Nl_{methane} \cdot gTVS^{-1}$.

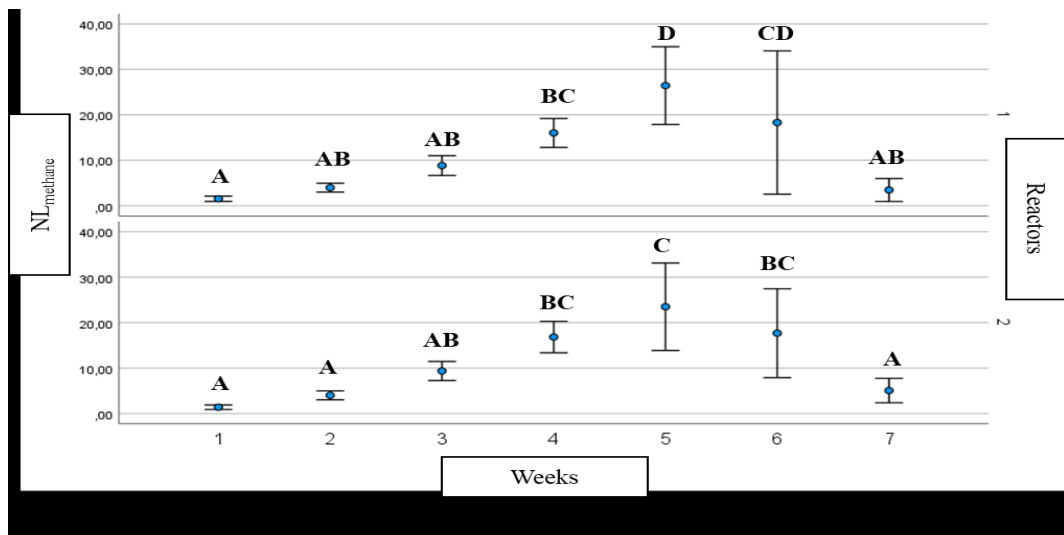

Figure 7.4 Weekly production of $Nl_{methane} \cdot gTVS^{-1}$ for the trial weeks. Data marked with different capital letters are significantly different by Tukey's test ($p < 0.05$).

The feed was increased throughout the experiment and consequently also the amount of TVS and COD increased (Figures 7.5, 7.6 and 7.7). The experiment was non-significant only for reactor 1: $F(1,6) = 37.864$, $p > 0.05$ concerning the TVS parameter. Also, the Organic Loading Rate (OLR) was set weekly (Figure 7.8). The highest values were found in weeks 5 and 6 in both reactors.

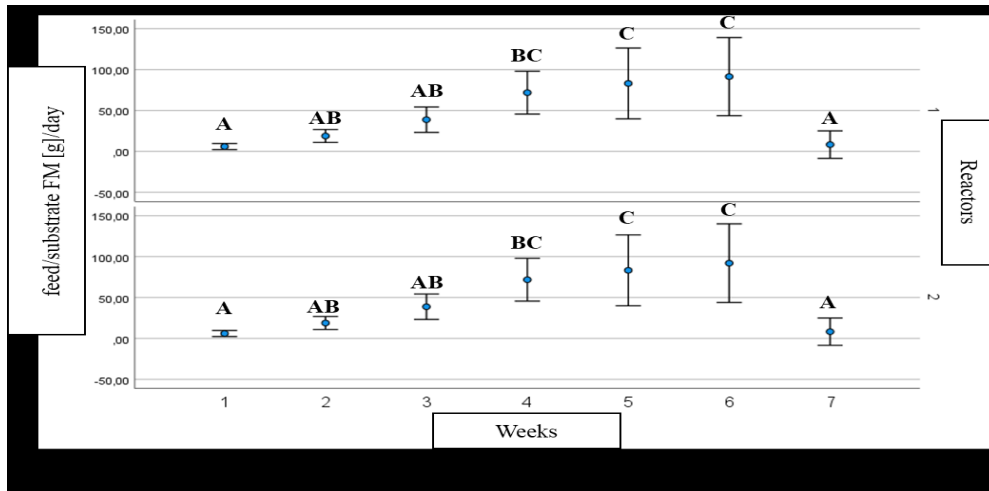

Figure 7.5 Feeding the reactors on substrate FM (fresh matter) added weekly. Data marked with different capital letters are significantly different by Tukey's test ($p < 0.05$).

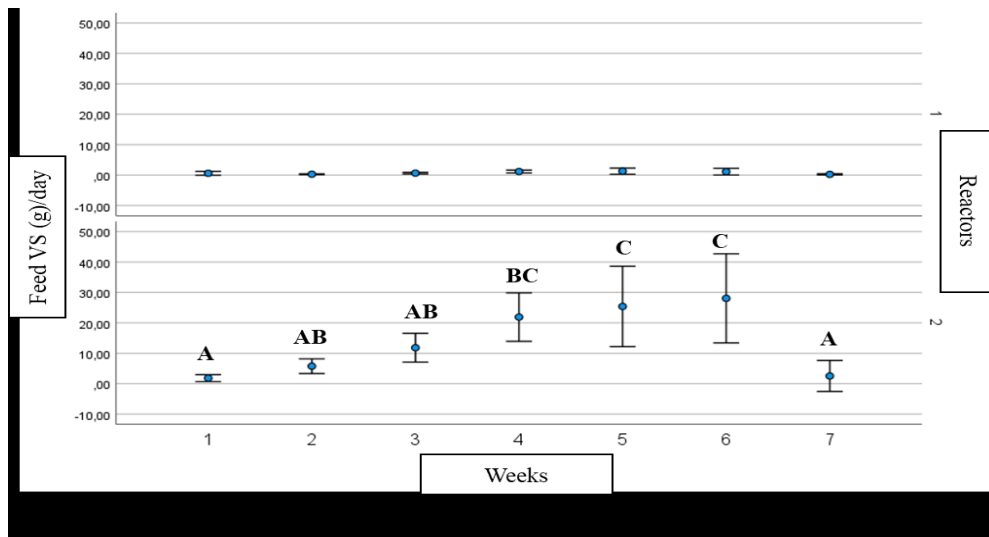

Figure 7.6 Feeding the reactors on substrate TVS added weekly. Data marked with different capital letters are significantly different by Tukey's test ($p < 0.05$).

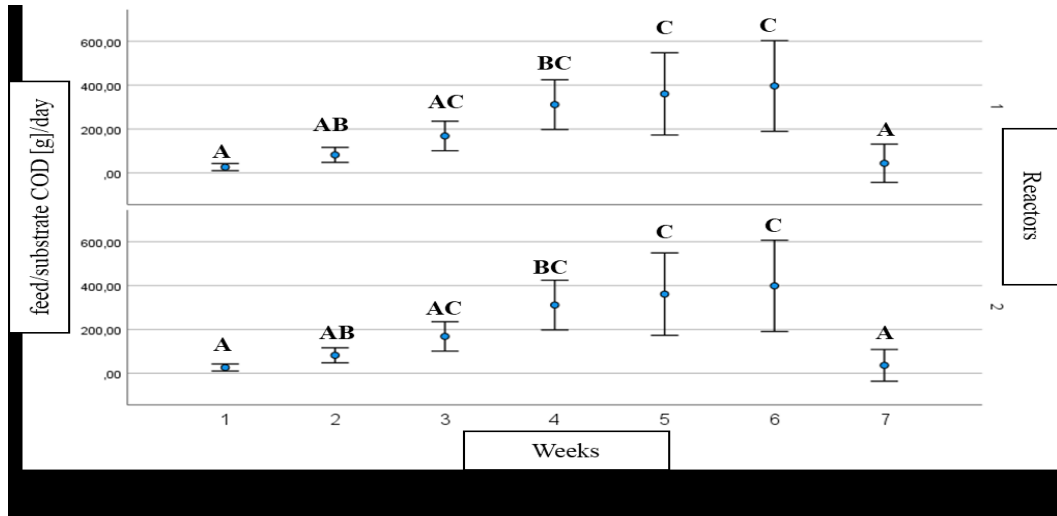

Figure 7.7 Feeding the reactors on substrate COD added weekly. Data marked with different capital letters are significantly different by Tukey's test ($p < 0.05$).

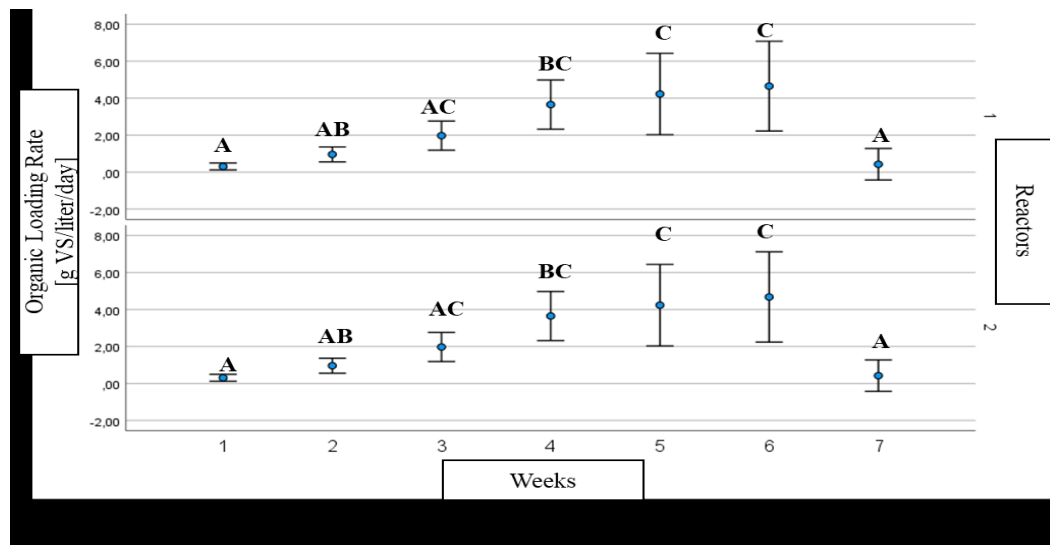

Figure 7.8 Variation of OLR weekly. Data marked with different capital letters are significantly different by Tukey's test ($p < 0.05$).

Finally, the percentages of methane and other gases were evaluated (the results are shown in Figures 7.9 to 7.13). The methane amount remained fairly stable during the first five weeks. From the fifth week on, a decrease in the methane amount in favour of CO_2 could be observed due to the inhibition of the methanogenic bacteria. As indicated by the graphs, we found that methane production from the end of the fifth week had dropped considerably with very important increases in CO_2 levels.

This can only indicate that the digestive process was impaired by the action of the methanogenic bacteria (Cecchi et al., 2005). Furthermore, it could be observed that there was an increase in the concentration of H₂S in the gas phase, which is one of the other warning signs indicating that the process may have been compromised.

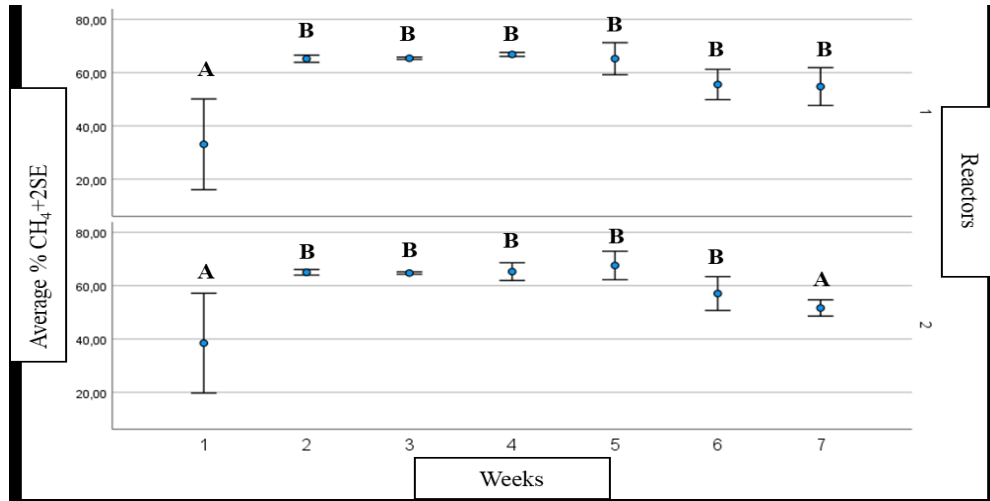

Figure 7.9 Variation in percentage concentration of CH₄ during the trial weeks. Data marked with different capital letters are significantly different by Tukey's test ($p < 0.05$)

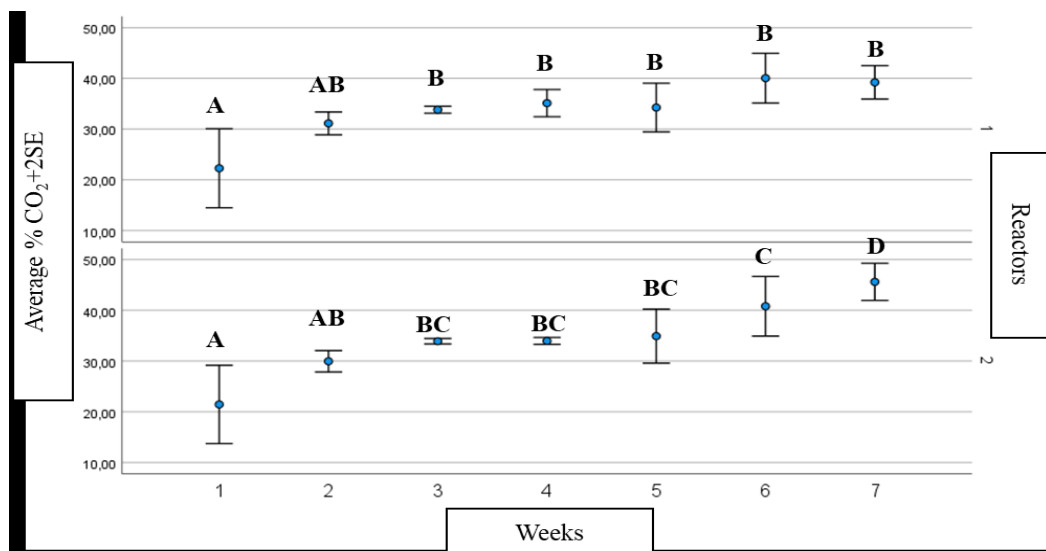

Figure 7.10 Variation in percentage concentration of CO₂ during the trial weeks. Data marked with different capital letters are significantly different by Tukey's test ($p < 0.05$)

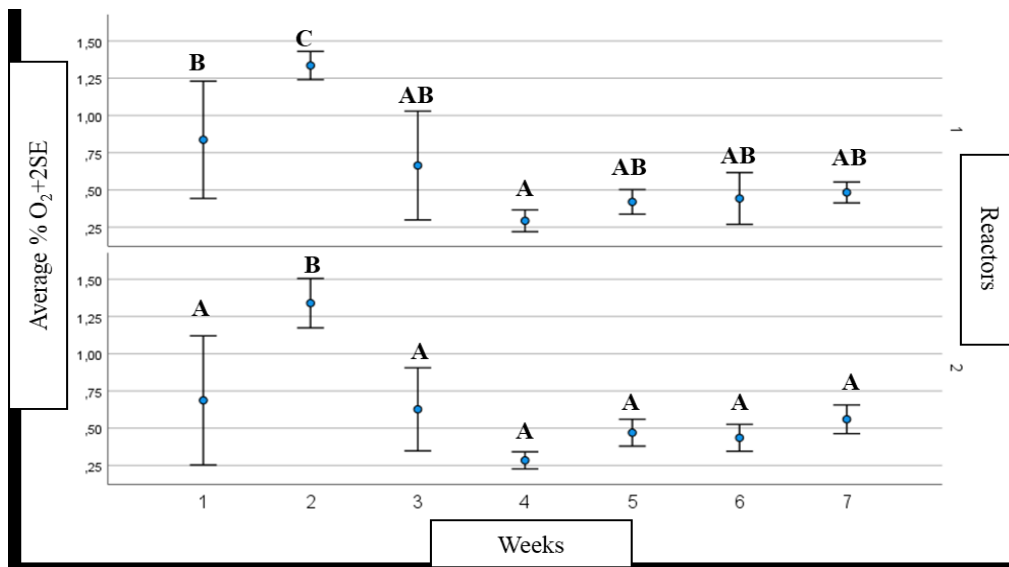

Figure 7.11 Variation in percentage concentration of O₂ during the trial weeks. Data marked with different capital letters are significantly different by Tukey's test ($p < 0.05$)

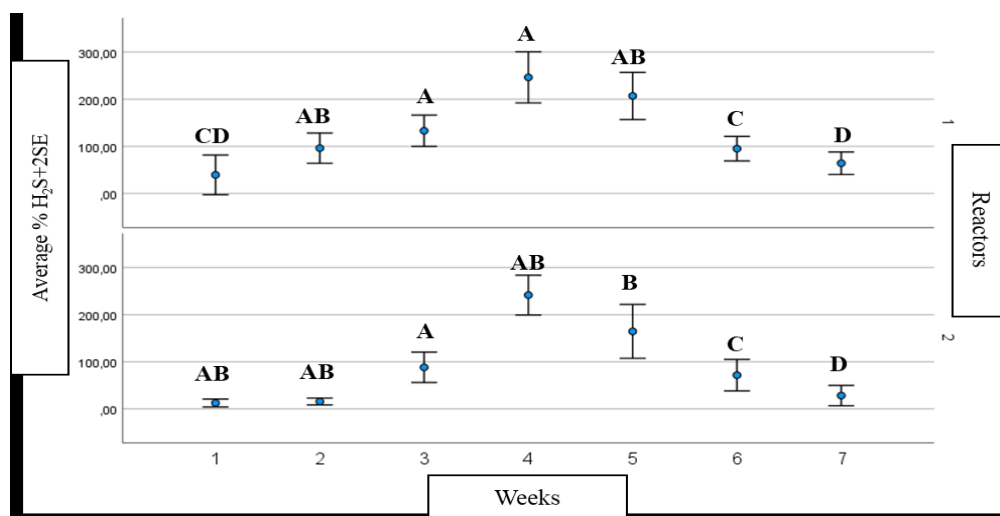

Figure 7.12 Variation in percentage concentration of H₂S during the trial weeks. Data marked with different capital letters are significantly different by Tukey's test ($p < 0.05$)

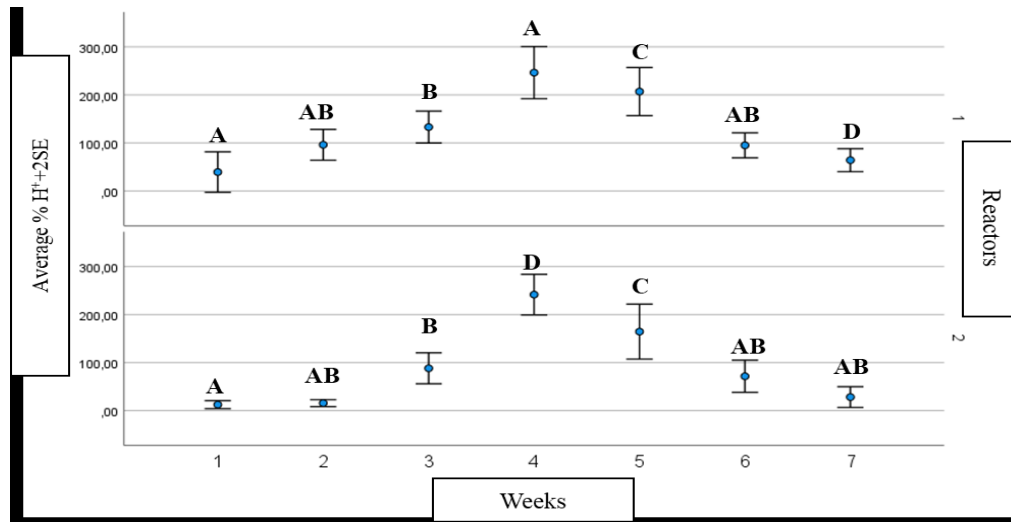

Figure 7.13 Variation in percentage concentration of H^+ during the trial weeks. Data marked with different capital letters are significantly different by Tukey's test ($p < 0.05$)

The cumulative production, normalized, indicated that reactor 2 had been the more productive in terms of bio-methane produced with $410.86 \text{ Nl}_{\text{methane}} \cdot \text{gTVS}^{-1}$, while reactor 1 produced $394.57 \text{ Nl}_{\text{methane}} \cdot \text{gTVS}^{-1}$. It is immediately apparent from the statistical analysis that both reactors experienced a drastic drop in bio-methane yield between the sixth and seventh week of experimentation, which was probably due to an imbalance between the liquid and gaseous phases.

According to the literature, to consider the process chemically stable, reference must be made to the pH value, which must be between 6.5 and 7 (Cecchi et al., 2005). In my case, although there was no drastic drop in pH, this probably triggered inhibitory phenomena against the methanogenic bacterial consortium. The pH in this case dropped from an initial 8.18 in both reactors to a pH of 7.16 in reactor 1 and a pH of 7.32 in reactor 2. This lowering was probably caused by a concatenation of events including an increase in the concentration of total volatile fatty acids (tVFA) in the medium, a decrease in the concentration of methane in favour of CO_2 and finally an increase in the concentration of H_2S . As indicated by the physical-chemical characterization table of the samples taken from both reactors, high tVFA concentrations (reactor 1: 31.77 g/l and reactor 2: 25.55 g/l) were recorded at time T27 in conjunction with the increase in feed. It can be seen that as daily feeding increases, there is an increase in all parameters. This increase in the concentration

of total volatile fatty acids was able to considerably lower the buffering capacity of the system, leading to toxic conditions in the reactor (Franke-Whittle et al., 2014). Various VFAs exist in AD and have different, interactive effects on bacteria and archaea. Wang et al. (2009) reported that acetic acid and butyric acid concentrations of 2400 and 1800 mg/l⁻¹, respectively, produced no significant inhibition of methanogen activity, whereas a propionic acid concentration of 900 mg l⁻¹ produced a significant inhibition of methanogen activity. Opinions vary as to which VFA is the best indicator of impending reactor failure, with several authors suggesting i-butyric, i-valeric, propionic acid or the propionic/acetic acid ratio as the most appropriate indicator (Boe et al., 2006). However, it does not seem possible to define VFA levels to indicate the state of an anaerobic process, as different systems have their own VFA levels that can be considered 'normal' for the reactor and conditions that cause instability in one reactor. do not cause problems in another reactor (Angelidaki et al., 1993). While lowering CH₄ production and increasing CO₂ is another symptom of acidification of the medium, with an imbalance of the methanogenic bacterial consortium in favour of fermentative bacteria. Organic substrates or raw materials used in anaerobic digestion always contain sulphur-containing compounds. Methionine and cysteine are sulphur-containing amino acids common in proteins (Vu et al., 2021). As the substrate used (80% curd + 20% expired sausages) is very rich in protein and thus also in amino acids, it caused a significant production of H₂S. As mentioned above, the increased concentration of H₂S (hydrogen sulphide) in the gas phase is also a sign of possible "intoxication" of the methanogenic bacteria. H₂S is toxic to methanogens in the range of 50 to 220 mg S/l at pH 7-8, thus further suppressing CH₄ production (Dyksta et al., 2021). The H₂S concentration in biogas varies from 100 to 10,000 ppm depending on the sulphur content of the feedstock (e.g. 115 mg S/kg sewage sludge and 600 mg S/kg cattle manure (Choudhury et al., 2019). In this case, the concentration was quantified as 3520 ppm in reactor 1, T49 and 1969 ppm in reactor 2 in T49. These results are also in line with the chemical analyses that were conducted on the samples taken from the reactors. From Tables 7.4 → 7.5 and 7.6 → 7.7, it can be seen that the ammonium and TKN values increase as the amount of feed increases. In summary, many contributing factors led to a reduction in bio-methane production

and this caused the premature abortion of the experiment. The data suggests, that a slower increase in feed would have led to a better adaptation of the microbial consortia and therefore a stable operation, also at higher loading rates.

7.6 Conclusions

This study enhances our understanding of the anaerobic digestion process of animal by-products. While dairy and meat by-products are not commonly used in anaerobic digestion plants, they contain significant amounts of energy and have the potential to become excellent substrates for bio-methane production in the future, but the elevated hydrogen sulfate and ammonium levels have to be considered originating from the high protein fraction. To avoid an unstable process or even the inhibition of the methanogenesis the feed has to be increased at a much lower pace compared to anaerobic digestion processes using substrates with a low protein fraction, like agri-biogas systems fermenting plants. The slow increase in feed allows the adaptation of the microbial community without steering into inhibition.

This study confirms the applicability of anaerobic digestion for the treatment of protein-rich waste streams from the food industry and especially from the dairy and meat-producing sectors, it could be very interesting to replicate the experiment by trying to automate the whole process as much as possible, as suggested by Scarcello et al. (2023). Current policies and subsidies encourage the use of co-products rather than energy crops for renewable energy production, which could provide a further stimulus for the uptake of small-scale plants along the agri-food supply chain (Benali et al. 2021; Zema et al. 2018).

REFERENCES

Angelidaki, I.; Ellegaard, L.; Ahring, B.K. A mathematical model for dynamic simulation of anaerobic digestion of complex substrates: focusing on ammonia inhibition. *Biotechnol. Bioeng.* 1993. 42, 159–166.

Assalzo. Available online:

<https://www.assalzo.it/scopri-il-settore/statistiche/bilancio-alimentare-deiprodotti-di-origine-animale/> (accessed on 10 January 2024).

Assolatte. Available online:
https://www.senato.it/documenti/repository/commissioni/comm10/documenti_acquisiti/IC%20competitivita/2009_12_15%20-%20Assolatte.pdf (accessed on 25 January 2024).

Asunis, F.; De Gioannis, G.; Dessì, P.; Isipato, M.; Lens, P.N.L.; Muntoni, A.; Poletti, A.; Pomi, R.; Rossi, A.; Spiga, D. The dairy biorefinery: integrating treatment processes for cheese whey valorisation. *J. Environ. Manag.* 2020. 276, 111240. <https://doi.org/10.1016/j.jenvman.2020.111240>.

Benalia, S.; Falcone, G.; Stillitano, T.; De Luca, A.I.; Strano, A.; Gulisano, G.; Zimbalatti, G.; Bernardi, B. Increasing the Content of Olive Mill Wastewater in Biogas Reactors for a Sustainable Recovery: Methane Productivity and Life Cycle Analyses of the Process. *Foods* 2021,. <https://doi.org/10.3390/foods10051029>

Bernardi, B.; Benalia, S.; Zema, D.A.; Tamburino, V.; Zimbalatti, G. An automated medium scale prototype for anaerobic co-digestion of olive mill wastewater. *Inf Process Agric.* 2017, 4(4), 316–320. doi.org/10.1016/j.inpa.2017.06.004

Boe, K., 2006. Online monitoring and control of the biogas process. PhD thesis, Institute of Environment and Resources, Technical University of Denmark.

Cecchi F., Battistoni P., Pavan., Bolzonella D., Innocenti L. 2005. “Digestione anaerobica della frazione organica dei rifiuti solidi. Aspetti fondamentali, progettuali, gestionali, di impatto ambientale ed integrazione con la depurazione delle acque reflue”. Edizioni APAT: Agenzia per la Protezione dell’Ambiente e per i Servizi Tecnici. Manuali e linee guida 13/2005, Roma

Chen, H., Chang, S. Dissecting methanogenesis for temperature-phased anaerobic digestion: Impact of temperature on community structure, correlation, and fate of methanogens. *Bioresour. Technol.* 2020, 306, 123104. <https://doi.org/10.1016/j.biortech.2020.123104>.

Choudhury, A., Shelford, T., Felton, G., Gooch, C., Lansing, S.,. Evaluation of Hydrogen Sulfide Scrubbing Systems for Anaerobic Digesters on Two U.S. Dairy Farms. *Energies* 2019, 12 (24), 4605.

Clal.Available online:
https://www.clal.it/index.php?section=siero_regioni&anno=2020 (accessed on 25 January 2024).

Comino, E.; Riggio, V.A.; Rosso, M.. Biogas production by anaerobic co-digestion of cattle slurry and cheese whey. *Bioresour. Technol.* 2012. 114, 46–53. <https://doi.org/10.1016/j.biortech.2012.02.090>.

Comino, E.; Rosso, M.; Riggio, V. Development of a pilot scale anaerobic digester for biogas production from cow manure and whey mix. *Bioresour. Technol.* 2009. 100 (21), 5072–5078. <https://doi.org/10.1016/j.biortech.2009.05.059>.

Dreschke, G.; Probst, M.; Walter, A.; Pümpel, T.; Walde, J.; Insam, H. Lactic acid and methane: Improved exploitation of biowaste potential. *Biores. Technol.* 2015, 47–55

Dykstra, C.M.; Pavlostathis, S.G.. Hydrogen sulfide affects the performance of a methanogenic bioelectrochemical system used for biogas upgrading. *Water Res.* 2021, 200, 117268.

Escalante, H.; Castro, L.; Amaya, M.P.; Jaimes, L. Anaerobic digestion of cheese whey: Energetic and nutritional potential for the dairy sector in developing countries. *Waste Manag.* 2017. <https://doi.org/10.1016/j.wasman.2017.09.026>

Fernández-Rodríguez, M.J.; Puntano, N.F.; Mancilla-Leytón, J.M.; Borja, R.. Batch mesophilic anaerobic co-digestion of spent goat batch mesophilic anaerobic co-digestion of spent goat straw bedding and goat cheese whey: comparison with the mono-digestion of the two sole substrates. *J. Environ. Manag.* 2021. 280, 111733. <https://doi.org/10.1016/j.jenvman.2020.111733>.

Franke-Whittle, I. H.; Walter, A.; Ebner, C.; Insam, H. Investigation into the effect of high concentrations of volatile fatty acids in anaerobic digestion on methanogenic communities. *Waste Manag.* 2014, 34(11), 2080–2089. <https://doi.org/10.1016/j.wasman.2014.07.020>

Gelegenis, J.; Georgakakis, D.; Angelidaki, I.; Mavris, V. Optimization of biogas production by co-digesting whey with diluted poultry manure. *Renew. Energy* 2007. 32 (13), 2147–2160. <https://doi.org/10.1016/j.renene.2006.11.015>.

Hublin, A., Zokić, T.I., Zelić, B. Optimization of biogas production from co-digestion of whey and cow manure. *Biotechnol. Bioprocess Eng.* 2012. 17 (6), 1284–1293. <https://doi.org/10.1007/s12257-012-0044-z>.

Hülsemann, B.; Zhou, L.; Merkle, W.; Hassa, J.; Müller, J.; Oechsner, H. Biomethane Potential Test: Influence of Inoculum and the Digestion System. *Appl. Sci.* 2020, 10, 2589. <https://doi.org/10.3390/app10072589>

IEA Bioenergy. Available online: www.ieabioenergy.com/blog/publications/process-monitoring-in-biogas-plants/ (accessed on 20 January 2024).

Karadag, D.; Köroğlu, O.E.; Ozkaya, B.; Cakmakci, M. A review on anaerobic biofilm reactors for the treatment of dairy industry wastewater. *Process Biochem.* 2015. 50 (2), 262–271. <https://doi.org/10.1016/j.procbio.2014.11.005>.

Kavacik, B.; Topaloglu, B. Biogas production from co-digestion of a mixture of cheese whey and dairy manure. *Biomass Bioenergy* 2010. 34 (9), 1321–1329. <https://doi.org/10.1016/j.biombioe.2010.04.006>.

KTBL. Gasausbeute in landwirtschaftlichen Biogasanlagen. *KTBL H 107.* 2015;36.

Labatut, R.A.; Angenent, L.T.; Scott, N.R. Biochemical methane potential and biodegradability of complex organic substrates. *Biores. Technol.* 2011, 102(3), 2255–2264. <https://doi.org/10.1016/j.biortech.2010.10.035>

Lovato, G.; Albanez, R.; Triveloni, M.; Ratusznei, S.M.; Rodrigues, J.A.D. Methane production by co-digesting vinasse and whey in an AnSBBR: effect of mixture ratio and feed strategy. *Appl. Biochem. Biotechnol.* 2019. 187 (1), 28–46. <https://doi.org/10.1007/s12010-018-2802-7>

Sar, T.; Harirchi, S.; Ramezani, M.; Bulkan, G.; Akbas, M.Y.; Pandey, A.; Taherzadeh, M.J. Potential utilization of dairy industries by-products and wastes through microbial processes: A critical review. *Sci. Total Environ.* 2022, 810. doi.org/10.1016/j.scitotenv.2021.152253

Scarcello, L., Benalia, S., Zimbalatti, G., Fazari, A., Bernardi, B. (2023). A Smart Automation System for the Management and Control of a Medium Scale Digester Plant. In: Ferro, V., Giordano, G., Orlando, S., Vallone, M., Cascone, G., Porto, S.M.C. (eds) AIIA 2022: Biosystems Engineering Towards the Green Deal. AIIA

2022. Lecture Notes in Civil Engineering, vol 337. Springer, Cham. https://doi.org/10.1007/978-3-031-30329-6_94

Szaja, A.; Montusiewicz, A. Enhancing the co-digestion efficiency of sewage sludge and cheese whey using brewery spent grain as an additional substrate. *Bioresour. Technol.* 2019. <https://doi.org/10.1016/j.biortech.2019.121863>

V. Verg, S. Substratcharakterisierung and V.D.I. (2006). INGENIEURE. In VDI-RICHTLINIEN Vergärung.

Vu, H.P.; Nguyen, L.N.; Wang, Q.; Ngo, H.H.; Liu, Q.; Zhang, X.; Nghiem, L.D. Hydrogen sulphide management in anaerobic digestion: A critical review on input control, process regulation, and post-treatment. *Bioresour. Technol.* 2022, 346, 126634. <https://doi.org/10.1016/j.biortech.2021.126634>

Wang, Y.; Zhang, Y.; Wang, J.; Meng, L.. Effects of volatile fatty acid concentrations on methane yield and methanogenic bacteria. *Biomass Bioenergy* 2009, 33, 848–853.

Zema, D.A.; Zappia, G.; Benalia, S.; Zimbalatti, G.; Perri, E.; Urso, E.; Tamburino, V.; Bernardi, B. Limiting factors for anaerobic digestion of olive mill wastewater blends under mesophilic and thermophilic conditions. *J. Agric. Eng* 2018, XLIX:792, pp. 130.137. DOI: 10.4081/jae.2018.792

8. CONCLUSIONS AND FUTURE PERSPECTIVES

This thesis focuses on the evaluation of increased biogas production through anaerobic digestion of agri-food by-products and food waste by first testing single substrates and then mixtures with different percentages of substrates using static BMP tests. Only when good results were obtained was it possible to use two CSTR reactors fed daily. For both the BMP tests and the two reactors, all start-up and operating parameters of the anaerobic digestion process were monitored, and both the substrates and the mixtures (both incoming and outgoing) were chemically and physically characterised. All trials were conducted by monitoring the biogas and biomethane production of the test samples on a daily basis. This made it possible to determine the production trend of each individual experiment. The chemical-physical characterisation of all the substrates subjected to anaerobic digestion was carried out by means of various tests, such as pH, total solids (TS) (%) were determined at 105 °C, total volatile solids (TVS) (% of dry content) were determined after incineration at 550 °C, chemical oxygen demand (COD), total polyphenol content (PPs), total Kjeldahl nitrogen (TKN), total volatile fatty acids (VFA). The pH remained fairly constant throughout the tests, in the range of 6.5 - 7. This indicates that the anaerobic digestion process is stable and that the methanogenic bacteria are able to break down the molecules and produce large quantities of methane. With regard to the total solids (TS) content in all four tests, we worked with a TS content below 10%, which allowed us to work under wet conditions (TS<10%), which is the optimal condition for processing these substrates. The measurement of total volatile solids was very useful to calculate the optimal substrate to inoculum ratio (S/I ratio). According to the literature, the optimal substrate to inoculum ratio must be < 0.5 to avoid problems with organic loading, and in our case it was decided to work with lower ratios between 0.2 and 0.4. In addition, it was decided to extend the analyses by also characterising the nitrogen profile through the determination of ammonium and TKN. When, as in this case, we are dealing with substrates with a high protein content, their determination is of primary importance. In fact, the nitrogen contained in proteins and amino acids, if present in the reactors in excess, has negative consequences for the methanogenic bacterial consortium, with the consequent inhibition or reduction

of their ability to grow and develop. The determination of total volatile fatty acids (tVFA) is a crucial parameter for evaluation. A sudden increase in the concentration of VFAs can cause a buffering effect on the bacterial consortium, leading to acidification of the mass being digested and inhibiting the methanogenic consortium. Out of the three tests involving the BMP test on the individual substrates and their mixtures, the most productive mixture overall was thesis 7, which contained 2% expired curds and 98% inoculum, and thesis 4, which contained 3% curds and 97% inoculum. These mixtures respectively produced thesis 7 = $2.68 \pm 3.90 \text{ NL}_{\text{methane}}\text{-gTVS}^{-1}$ or $629.88 \text{ Nm}^3/\text{t}[\text{TVS}]$ and thesis 4 = $2.65 \pm 20.13 \text{ NL}_{\text{methane}}\text{-gTVS}^{-1}$ or $610.87 \text{ Nm}^3/\text{t}[\text{TVS}]$. However, while these results are important from an experimental point of view, they may not be practical for real-world applications. Although mixtures have shown excellent biomethane production, it may be difficult for a plant to solely rely on a single source for energy. Therefore, co-digestion of multiple substrates is preferred as it is easier to obtain and avoids the seasonality of certain by-products. Mono-digestion has the potential to mitigate the cyclical nature of large quantities of waste produced mainly in the food industry, such as tomato peels and wastewater from olive mills, which would otherwise be destined for disposal.

The results of the two CSTR reactors fed daily were particularly noteworthy, as they recorded excellent methane production. It is noteworthy that even a slight change in a single parameter can cause significant changes in the entire process. Chapter 7 highlights several factors that contributed to the cessation of the methanogenic process, providing a better understanding of the dynamics within the reactors. The research has improved our understanding of the anaerobic digestion process. Repeating these experiments with a more suitable inoculum would have been beneficial. The quality and suitability of the inoculum used in all four trials was likely not appropriate for the anaerobic digestion of this type of substrate. Studies suggest that pig manure is more likely to digest substrates that are rich in protein and carbohydrates, making it more susceptible to degrading this type of waste. The inoculum used in this study was a mixture from three different waste treatment plants that used cattle manure as a starter. To avoid peaks in organic matter that could have halted the anaerobic digestion process, it was necessary to feed the

inoculum gradually, especially for the trial with the CSTR reactors. One potential task in this area is to create a universal inoculum that can effectively digest various types of waste. Additional experiments are needed to optimize and refine the process parameters, improving efficiency and sustainability. This presents a broad range of opportunities to enhance both the digestion process and the management and calibration of digesters. The results obtained so far demonstrate the efficiency of the anaerobic digestion process. This opens up the possibility of using it in small-scale plants and incorporating it into different production realities.

In conclusion, the anaerobic digestion process could be an excellent system for overcoming agro-industrial waste disposal and management problems, resulting in a double gain in terms of energy, economic and environmental returns.